

The **Straight Sided Insert (SI)** is a **threadless** check valve designed to be inserted into any cavity where a check valve is needed and threads are not desired. Consult the factory if your application requires tolerancing for a press fit installation. The SI valve can also be used as a low pressure relief valve or vacuum breaker by using the desired spring settings.

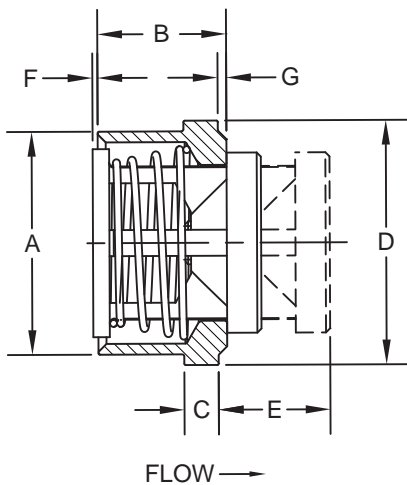

Nom. Pipe Size	Size Code	A	B	C	D	E <sup>1</sup>	F	G	Orifice Diameter
1/2	D	0.656	0.56	0.16	0.718	0.53	0.01	0.031	0.348
3/4	F	0.780	0.59	0.16	0.900	0.61	0.00	0.063	0.464
1	H	1.000	0.69	0.19	1.125	0.78	0.11	0.063	0.593
1-1/4	I	1.312	0.81	0.19	1.500	0.85	0.09	0.063	0.890
1-1/2	J	1.625	0.88	0.25	1.781	1.01	0.15	0.063	1.135
2	K	1.875	0.88	0.25	2.187	1.19	0.70	0.063	1.385

<sup>1</sup> Maximum nominal dimension for a fully open valve with no spring.

Body Material <sup>2</sup>	Availability	Non-Shock Pressure-Temperature Rating
316 Stainless Steel (SS)	Standard	3000 PSIG @ 100°F (1500 PSIG for o-ring seats)
Carbon Steel (CS)		
Brass (BR)		
Alloy 20 (A2)	Semi-standard	
Alloy C-276 (HC)		
Alloy 400 or Monel <sup>®</sup> (MO)		
Alloy B (HB)	Contact the factory for these or other materials.	
Titanium (TI)		

<sup>2</sup> See page 54 for material grade information.

**Straight Sided Insert**  
For Water at 72°F

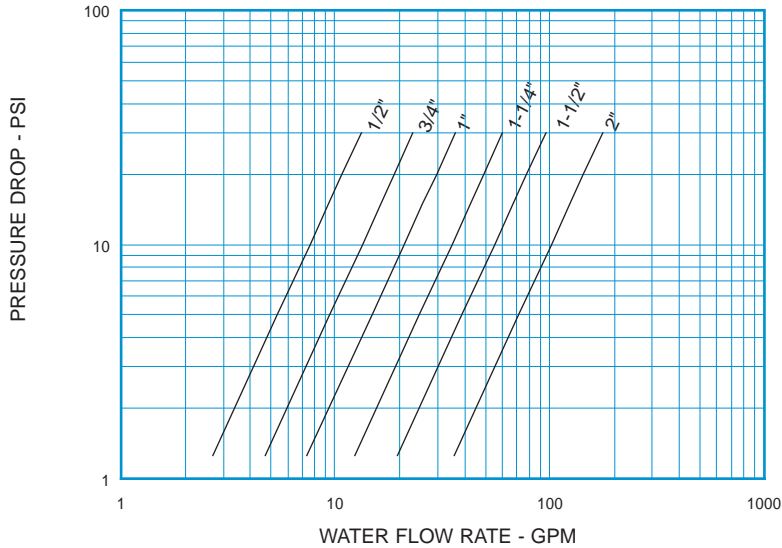

**Note:** All flow curves and Cv values presume the valves are fully open with 1/2 PSI cracking pressure springs. Consult the factory for more information.

STYLE SI C <sub>v</sub> VALUES & VALVE WEIGHTS		
C <sub>v</sub>	SIZE	ALL MATERIALS
2.4	1/2	0.6 oz.
4.2	3/4	1.0 oz.
6.6	1	1.7 oz.
11.0	1-1/4	3.3 oz.
17.4	1-1/2	5.3 oz.
32.0	2	8.2 oz.

See page 49 for Flow Formulae.  
Valve weights are approximate.

**HOW TO ORDER  
CHECK-ALL STYLE SI**

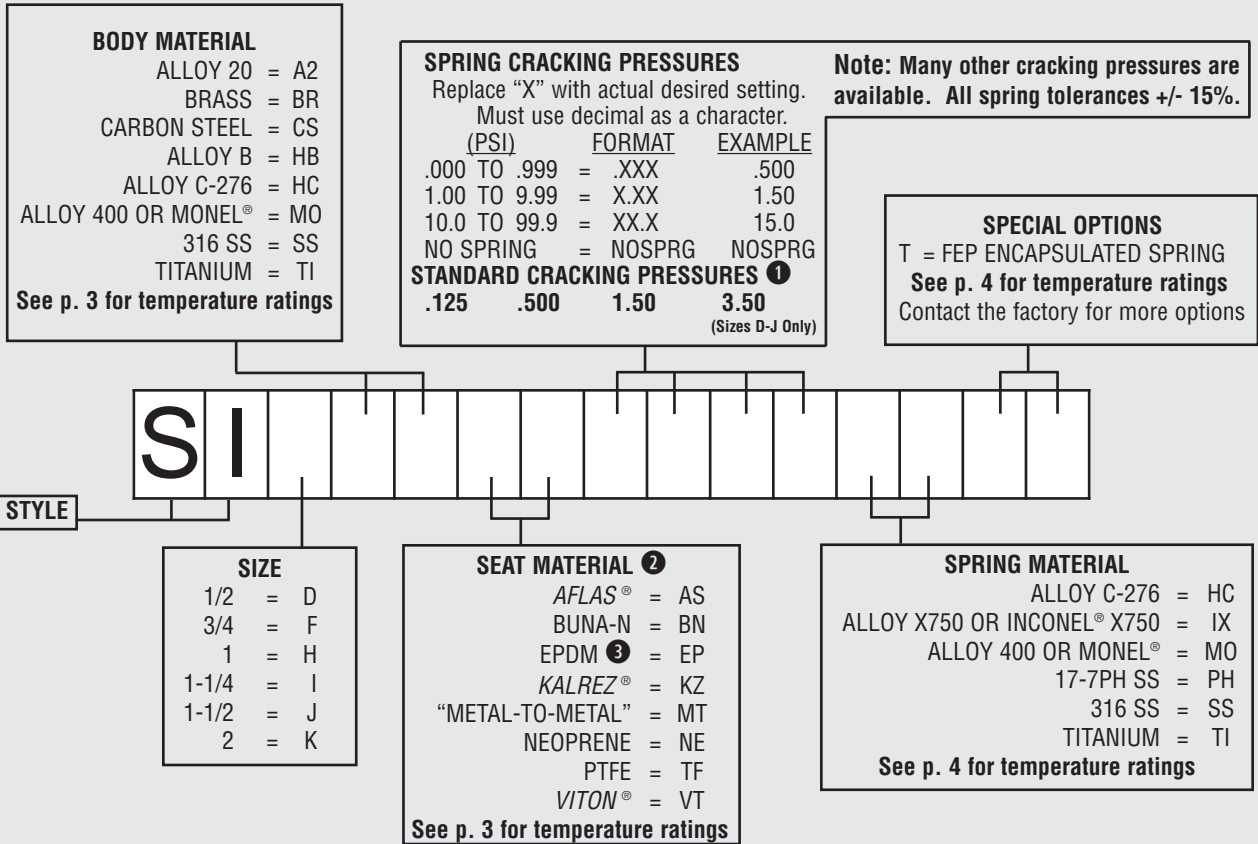

Listed above are the most common material selections. Please contact the factory for additional options.

- ① .500 PSI is the only standard cracking pressure for spring materials other than Stainless Steel. .125 PSI springs are not recommended for installations with flow vertical down.
- ② Seat materials other than "metal-to-metal" have a maximum pressure rating of 1500 PSI. "Metal-to-Metal" and PTFE seats are not resilient. See page 50 for allowable leakage rates.
- ③ EP seats not recommended for use with Carbon Steel valves.