

## OPTIMASS 2000 Technical Datasheet

Sensor for bulk mass flow

- Large diameter for bulk measurement and custody transfer of liquids and gases
- Stainless Steel measuring tubes (NACE Compliant)
- Super Duplex option offering a maximum operating pressure of 180 barg

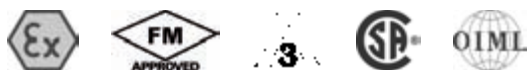

The documentation is only complete when used in combination with the relevant documentation for the converter.

1	Product features	3
<hr/>		
1.1	The solution for bulk mass flow measurement.....	3
1.2	Features and options.....	5
1.3	Meter / converter combinations.....	6
1.4	Measuring principle (twin tube) .....	6
2	Technical data	8
<hr/>		
2.1	Technical data.....	8
2.2	Measuring accuracy .....	13
2.3	Guidelines for maximum operating pressure.....	14
2.4	Dimensions and weights .....	16
2.4.1	Flanged versions.....	16
2.4.2	Hygienic versions .....	21
2.4.3	Heating jacket version .....	23
2.4.4	Purge port option .....	24
3	Installation	25
<hr/>		
3.1	Intended use .....	25
3.2	Mounting restrictions .....	25
3.2.1	General installation principles .....	25
3.2.2	Sunshades.....	27

## 1.1 The solution for bulk mass flow measurement

Whilst the OPTIMASS 2000 has been developed to meet the demanding custody transfer requirements of the oil and gas industry, it is well suited to bulk measurement in many applications. The option of Super Duplex (UNS S32750) provides a maximum operating pressure of 180 barg.

A high level of performance makes the OPTIMASS 2000 suitable for the bulk measurement of petroleum and oil as well as products like syrup, molasses and raw chemicals.

Combined with the power of the MFC 300, the OPTIMASS 2000 will provide accurate measurement of volume, mass; density and concentration.



- ① Comprehensive diagnostic capabilities.
- ② Standard electronics for all sensors with redundant storage of calibration and sensor data.
- ③ Standard flange process connections available.
- ④ Modular electronics with a range of output options (see separate documentation for details).



- ① Remote terminal box

**Highlights**

- Innovative twin measuring tube design with large tube size, provide high flow rate capacity
- Easily drained and easy to clean
- Optional heating jacket
- High accuracy for custody transfer
- Optimised flow divider for minimum pressure loss
- Modular electronics concept: electronics and sensor are easy to replace
- Super Duplex option for operating pressures up to 180 barg
- Secondary containment up to 150 barg

**Industries**

- Oil & Gas
- Waste Water
- Chemical
- Paper & Pulp
- Food & Beverage
- Pharmaceutical
- Fresh Water

**Applications**

- Bulk loading/unloading
- Custody transfer for volume and mass
- High Volume
- Pipeline measurement applications

## 1.2 Features and options

### Features



- Flow rates up to 2,300,000 kg/h / 84,510 lbs/min.
- Integrated electronics.
- Self Draining.
- Best in class for zero stability.

### Connection options



- Standard flanges with ratings up to 1500 lbs / PN160.
- Supports a wide range of industry standard hygienic connections.
- Hygienic connections (DN100 only) for bulk measurement in the food/beverage industry.

### Heating jacket and purge port



- Heating jacket option for use with temperature dependant products.
- Prevents solidification of process product.
- Purge port option for protection in the event of measuring tube failure.
- Allows hazardous chemicals to be drained away safely.
- Can also be used for the early detection of measuring tube failure where highly toxic chemicals are being measured.

### 1.3 Meter / converter combinations

Converter	MFC 010	MFC 300			
Configuration	Compact	Compact	Remote field	Remote wall	Remote rack
OPTIMASS 2000	2010C	2300C	2300F	2300W	2300R

### 1.4 Measuring principle (twin tube)

Static meter not energised and with no flow

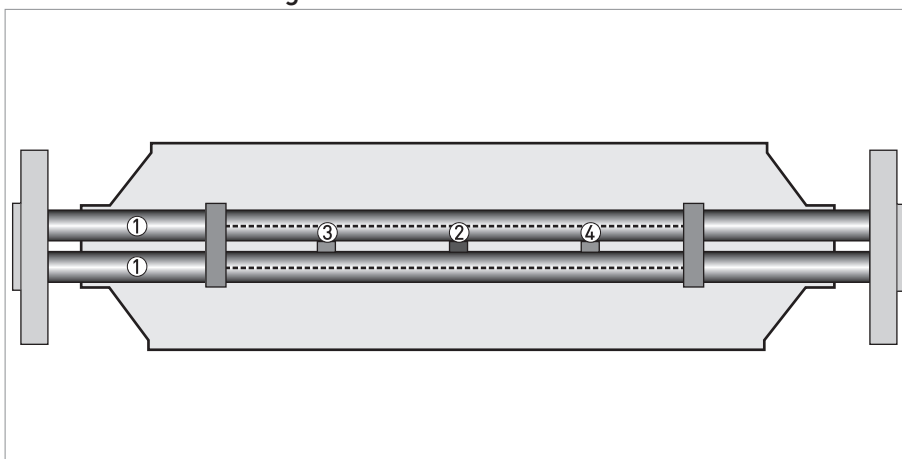

- ① Measuring tubes
- ② Drive coil
- ③ Sensor 1
- ④ Sensor 2

A Coriolis twin tube mass flowmeter consists of two measuring tubes ① a drive coil ② and two sensors (③ and ④) that are positioned either side of the drive coil.

Energised meter

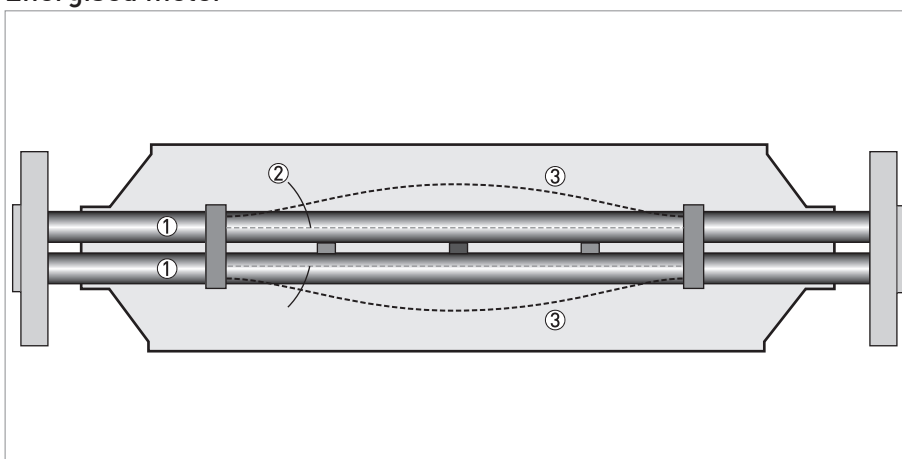

- ① Measuring tubes
- ② Direction of oscillation
- ③ Sine wave

When the meter is energised, the drive coil vibrates the measuring tubes causing them to oscillate and produce a sine wave ③. The sine wave is monitored by the two sensors.

### Energised meter with process flow

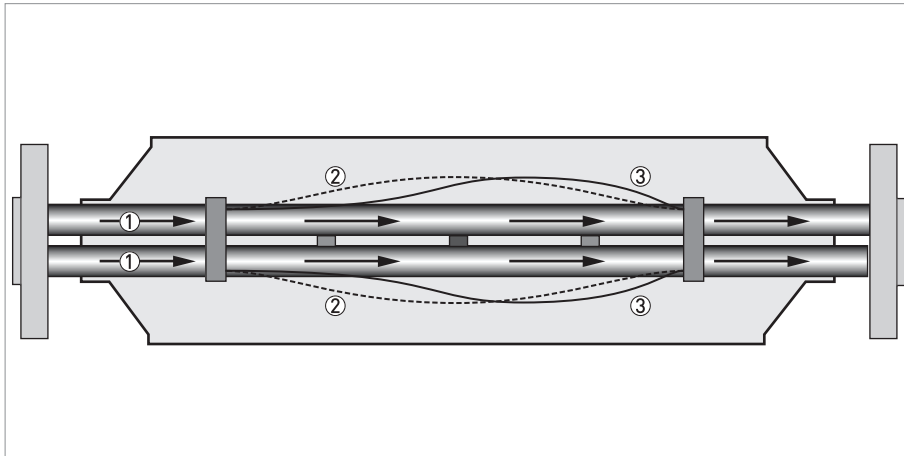

- ① Process flow
- ② Sine wave
- ③ Phase shift

When a fluid or gas passes through the tubes, the coriolis effect causes a phase shift in the sine wave that is detected by the two sensors. This phase shift is directly proportional to the mass flow.

Density measurement is made by evaluation of the frequency of vibration and temperature measurement is made using a Pt500 sensor.

## 2.1 Technical data

- *The following data is provided for general applications. If you require data that is more relevant to your specific application, please contact us or your local representative.*
- *Additional information (certificates, special tools, software,...) and complete product documentation can be downloaded free of charge from the website (Download Center).*

### Measuring system

Measuring principle	Coriolis mass flow
Application range	Mass flow and density measurement of fluids, gases and solids
Measured values	Mass, density, temperature
Calculated values	Volume, referred density, concentration, velocity

### Design

Basic	System consists of a measuring sensor and a converter to process the output signal
Features	Fully welded maintenance free sensor with dual-straight measuring tube
<b>Variants</b>	
Compact version	Integral converter
Remote version	Available with field, wall or 19" rack mount versions of the converter
Modbus version	Sensor with integral electronics providing Modbus output for connection to a PLC

### Measuring accuracy

<b>Mass</b>	
Liquid	$\pm 0.1\%$ of actual measured flow rate + zero stability
Gas	$\pm 0.5\%$ of actual measured flow rate + zero stability
Repeatability	Better than 0.05% plus zero stability (includes the combined effects of repeatability, linearity and hysteresis)
<b>Zero stability</b>	
S100	< 7 kg/h
S150	< 18 kg/h
S250	< 50 kg/h
<b>Reference conditions</b>	
Product	Water
Temperature	+20°C / +68°F
Operating pressure	1 barg / 14.5 psig
<b>Effect on sensor zero point caused by a shift in process temperature</b>	
Stainless Steel	0.0004% per 1°C / 0.000022% per 1°F
<b>Effect on sensor zero point caused by a shift in process pressure</b>	
Stainless Steel	0.0002% of the max flow rate per 1 bar <sub>rel.</sub> / 0.0000014% of the max flow rate per 1 psig
<b>Density</b>	
Measuring range	400...3000 kg/m <sup>3</sup> / 25...187 lbs/ft <sup>3</sup>
Accuracy	$\pm 2$ kg/m <sup>3</sup> / $\pm 0.13$ lbs/ft <sup>3</sup>



On site calibration	$\pm 0.5 \text{ kg/m}^3 / \pm 0.033 \text{ lbs/ft}^3$
<b>Temperature</b>	
Accuracy	$\pm 1^\circ\text{C} / \pm 1.8^\circ\text{F}$

### Operating conditions

<b>Maximum flow rates</b>	
S100	420000 kg/h / 14698 lbs/min
S150	900000 kg/h / 33804 lbs/min
S250	2300000 kg/h / 84510 lbs/min
<b>Custody transfer flow rates (mass)</b>	
S100	11000...220000 kg/h / 404...8083 lbs/min
S150	25000...500000 kg/h / 919...18371 lbs/min
S250	60000...1200000 kg/h / 2205...44092 lbs/min
<b>Custody transfer flow rates (volume)</b>	
S100	11...220 m <sup>3</sup> /h / 1660...33210 bbl/day
S150	25...500 m <sup>3</sup> /h / 3774...75478 bbl/day
S250	60...1200 m <sup>3</sup> /h / 9057...181147 bbl/day
Assumes operating density 1000 kg/m <sup>3</sup> / 62.4 lb/ft <sup>3</sup>	
<b>Ambient temperature</b>	
Compact version with Aluminium converter	-40...+60°C / -40...+140°F
	Extended temperature range: 65°C / 149°F for some I/O options. For more information contact manufacturer.
Compact version with Stainless Steel converter	-40...+55°C / -40...+130°F
Remote versions	-40...+65°C / -40...+149°F
<b>Process temperature</b>	
Flanged connection	-45...+130°C / -49...+266°F
Hygienic connection (S100 only)	
<b>Nominal pressure at 20°C / 68°F</b>	
<b>Measuring tube (Duplex UNS S31803)</b>	
PED 97/23/EC	-1...150 barg / -14.5...2175 psig
FM	-1...140 barg / -14.5...2030 psig
CRN / ASME B31.3	-1...100 barg / -14.5...1450 psig
<b>Measuring tube (Super Duplex UNS S32750)</b>	
PED 97/23/EC	-1...180 barg / -14.5...2610 psig
FM	-1...140 barg / -14.5...2030 psig
CRN / ASME B31.3 (pending)	-1...130 barg / -14.5...1885 psig
<b>Outer cylinder</b>	
Non PED / CRN approved	Typical burst pressure > 100 barg / 1450 psig
PED approved secondary containment	-1...40 barg / -14.5...580 psig
	-1...150 barg / -14.5...2175 psig (Duplex option)
<b>Effect on sensor zero point caused by a shift in process temperature</b>	
Stainless Steel	0.0004% per 1°C / 0.000022% per 1°F

<b>Effect on sensor zero point caused by a shift in process pressure</b>	
Stainless Steel	0.0002% of the max flow rate per 1 bar <sub>rel.</sub> / 0.0000014% of the max flow rate per 1 psig
<b>Fluid properties</b>	
Permissible physical condition	Liquids, gases, slurries
Permissible gas content (volume)	Contact manufacturer for information.
Permissible solid content (volume)	Contact manufacturer for information.
Protection category (acc. to EN 60529)	IP 67, NEMA 4X
<b>Installation conditions</b>	
Inlet runs	None required
Outlet runs	None required

## Materials

Measuring tube	Stainless Steel UNS S31803 (1.4462)
	Optional UNS S32750 (1.4410)
Spigot	Stainless Steel UNS J92205 (1.4470)
	Optional UNS J93404 (1.4469)
Flanges	Stainless Steel AISI 316 / 316L (1.4401 / 1.4404) dual certified
	Optional Stainless Steel UNS S31803 (1.4462) (NACE approved)
	Optional UNS S32750 (1.4410) (NACE approved)
Outer cylinder	Stainless Steel AISI 304 / 304L (1.4301 / 1.4307) dual certified
	Optional Stainless Steel AISI 316 / 316L (1.4401 / 1.4404) dual certified
	Optional Stainless Steel UNS S31803 (1.4462) ①
<b>Heating jacket version</b>	
Heating jacket	Stainless Steel 316L (1.4404)
	Note: the outer cylinder is in contact with the heating medium
<b>All versions</b>	
Sensor electronics housing	Stainless Steel 316L (1.4409)
	Optional Stainless Steel 316 (1.4469)
Junction box (remote version)	Die cast Aluminium (polyurethane coating)

## Process connections

<b>Flange</b>	
DIN	DN100...300 / PN16...160
ASME	4...12" / ASME 150...1500
JIS	100A / 10...20K
<b>Hygienic</b>	
Tri-clover	4"
Tri-clamp DIN 32676	DN100
Tri-clamp ISO 2852	4"
DIN 11864-2 Form A	DN100
Male thread DIN 11851	DN100
Male thread SMS	4"
Male thread IDF / ISS	4"
Male thread RJT	4"

## Electrical connections

Electrical connections	For full details, including: power supply, power consumption etc., see technical data for the relevant converter.
I/O	For full details of I/O options, including data streams and protocols, see technical data for the relevant converter.

## Approvals

<b>Mechanical</b>	
Electromagnetic compatibility (EMC) acc. to CE	Namur NE 21/5.95
	2004/108/EC (EMC)
	2006/95/EC (Low Voltage Directive)
European Pressure Equipment Directive	PED 97-23 EC (acc. to AD 2000 Regelwerk)
Factory Mutual / CSA	Class I, Div 1 groups A, B, C, D
	Class II, Div 1 groups E, F, G
	Class III, Div 1 hazardous areas
	Class I, Div 2 groups A, B, C, D
	Class II, Div 2 groups F, G
	Class III, Div 2 hazardous areas
ANSI / CSA (Dual Seal)	12.27.901-2003
Hygienic	3A 28-03
	ASME BPE
Custody Transfer	MID 2004/22/EC MI-005
<b>ATEX (acc. 94/9/EC)</b>	
<b>OPTIMASS 2300C non Ex i Signal outputs</b>	
Ex d connection compartment	II 2 G Ex d [ib] IIC T6....T1
	II 2 D Ex tD A21 IP6x T160°C
Ex e connection compartment	II 2 G Ex de [ib] IIC T6....T1
	II 2 D Ex tD A21 IP6x T160°C
<b>OPTIMASS 2300C Ex i signal outputs</b>	
Ex d connection compartment	II 2(1) G Ex d [ia/ib] IIC T6....T1
	II 2(1) D Ex tD [iaD] A21 IP6x T160°C
Ex e connection compartment	II 2(1) G Ex de [ia/ib] IIC T6....T1
	II 2(1) D Ex tD [iaD] A21 IP6x T160°C
<b>OPTIMASS 2000 / 2010C</b>	II 2 G Ex ib IIC T6....T1
	II 2 D Ex ibD 21 T165 °C

① Where this option is ordered, the electronics stem material is UNS J92205 (1.4470)

## ATEX (acc. 94/9/EC) temperature limits

	Ambient temp. T <sub>amb</sub> °C	Max. medium temp. T <sub>m</sub> °C	Temp. class	Max. surface temp. °C
OPTIMASS 2000 / 2010C with or without heating jacket / insulation	40	65	T6	T80
		75	T5	T95
		110	T4	T130
		130	T3-T1	T150
	65	75	T5	T95
		110	T4	T130
130		T3-T1	T150	
OPTIMASS 2300C Aluminium converter housing - with or without heating jacket / insulation	40	50	T6	T80
		65	T5	T95
		100	T4	T130
		130	T3-T1	T160
	50	65	T5	T95
		100	T4-T1	T130
	60	60	T4-T1	T90
	65 ①	65	T4-T1	T95
OPTIMASS 2300C Stainless Steel converter housing - with or without heating jacket / insulation	40	50	T6	T80
		65	T5	T95
		100	T4	T130
		120	T3-T1	T150
	50	65	T5	T95
		75	T4-T1	T105
	55	55	T5-T1	T85

① depending on I/O option. Please call for more information.

## Maximum end loadings

		S100	S150	S250
<b>Flanges</b>				
20°C	40 barg	150kN	350kN	550kN
	100 barg	100kN	120kN	60kN
	150 barg			
	180 barg			
130°C	32 barg	150kN	280kN	400kN
	80 barg	60kN	50kN	50kN
	115 barg			
	130 barg			
<b>Hygienic (all connections)</b>				
130°C	10 barg	5kN	-	-

## 2.2 Measuring accuracy

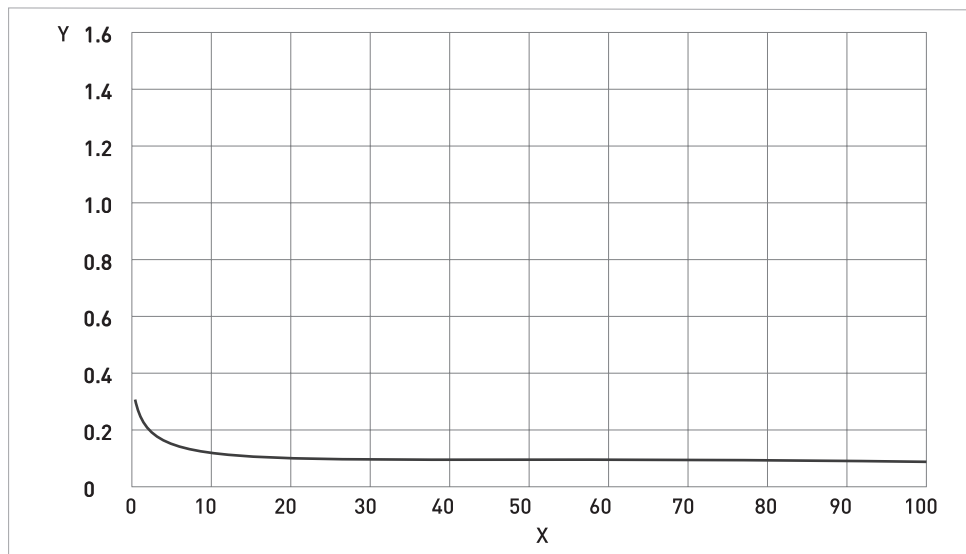

X flow rate [%]

Y measuring error [%]

### Measuring error

The measuring error is obtained from the combined effects of accuracy and zero stability.

### Reference conditions

Product	Water
Temperature	+20°C / +68°F
Operating pressure	1 barg / 14.5 psig

### 2.3 Guidelines for maximum operating pressure

**Notes:**

- Ensure that the meter is used within its operating limits
- All hygienic process connections have a maximum operating rating of 10 barg at 130°C / 145 psig at 266°F

**Pressure / temperature de-rating, all meter sizes in metric (flanged connections as per EN 1092-1:2007)**

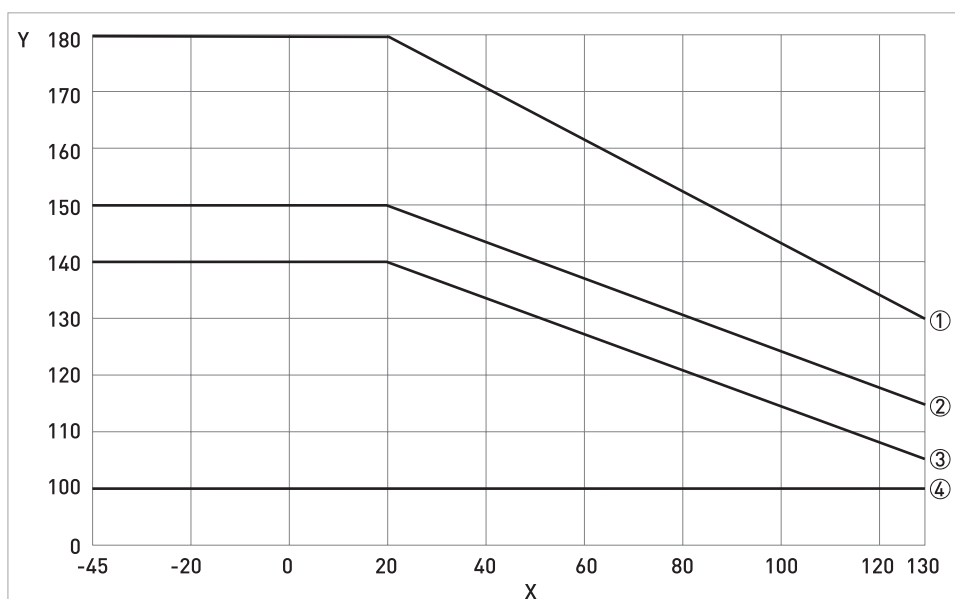

X temperature [°C]  
Y pressure [barg]

- ① Measuring tube (UNS S32750) PED certification
- ② Measuring tube (UNS S31803) PED certification
- ③ Measuring tube (UNS S31803 / S32750) FM certification
- ④ Measuring tube (UNS S31803) CRN certification

**Linear de-rating of PED certified secondary containment**

Outer cylinder material	-45°C	20°C	130°C
304 / L or 316 / L	40 barg	40 barg	32 barg
UNS S31803	150 barg	150 barg	100 barg

### Pressure / temperature de-rating, all meter sizes, in imperial (flanged connections as per ASME B16.5)

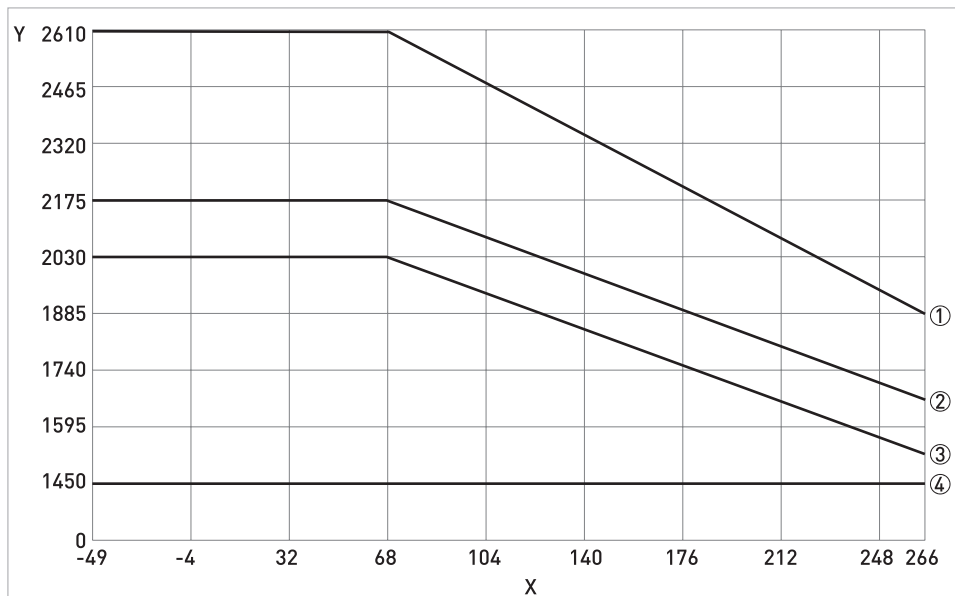

X temperature [°F]

Y pressure [psig]

- ① Measuring tube (UNS S32750) PED certification
- ② Measuring tube (UNS S31803) PED certification
- ③ Measuring tube (UNS S31803 / S32750) FM certification
- ④ Measuring tube (UNS S31803) CRN certification

#### Linear de-rating of PED certified secondary containment

Outer cylinder material	-49°F	68°F	266°F
304 / L or 316 / L	580 psig	580 psig	464 psig
UNS S31803	2175 psig	2175 psig	1450 barg

#### Flanges

- DIN flange ratings are based on EN 1092-1 2007 table G.4.1 material group 14EO
- ASME flange ratings are based on ASME B16.5 2003 table 2 material group 2.2
- JIS flange ratings are based on JIS 2220: 2001 table 1 division 1 material group 022a

#### Notes

- The maximum operating pressure will be either the flange rating or the measuring tube rating, **WHICHEVER IS THE LOWER!**
- The manufacturer recommends that the seals are replaced at regular intervals. This will maintain the hygienic integrity of the connection.

## 2.4 Dimensions and weights

### 2.4.1 Flanged versions

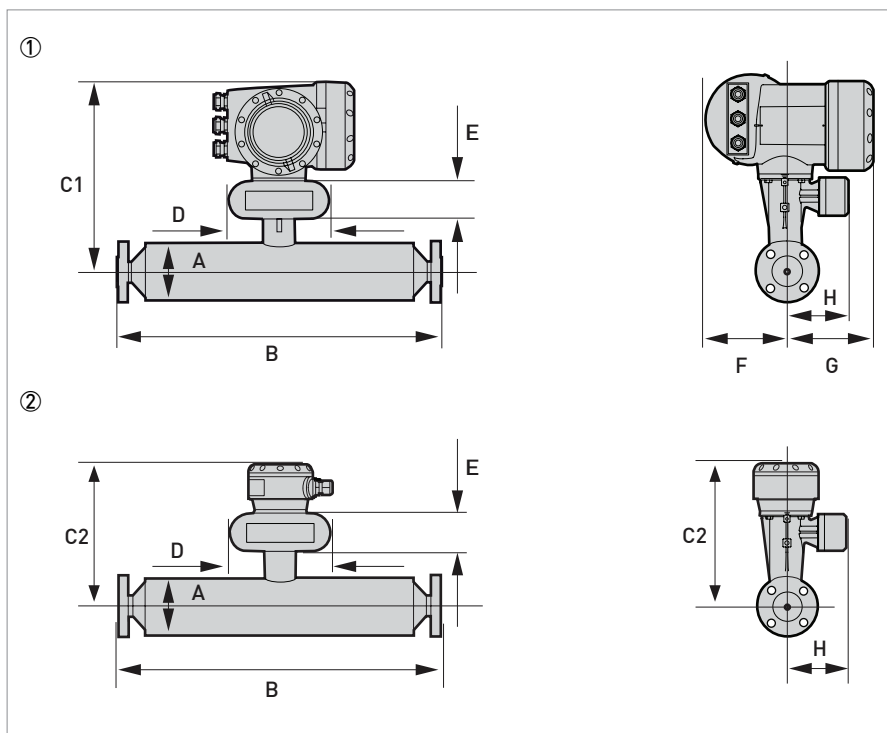

① Compact version  
 ② Remote version

#### Meter weights (PN40 flanges).

	Weight [kg]		
	S100	S150	S250
Aluminium (compact)	84.8	211.5	444.5
Stainless Steel (compact)	90.1	216.8	449.8
Aluminium (remote)	80.8	207.5	440.5
Stainless Steel (remote)	81.7	208.4	441.4

	Weight [lbs]		
	S100	S150	S250
Aluminium (compact)	187	466	980
Stainless Steel (compact)	198	478	991
Aluminium (remote)	178	457	971
Stainless Steel (remote)	180	459	973

For meter weights with different flange ratings, please contact the manufacturer.



## Measuring tube in Stainless Steel

	Dimensions [mm]		
	S100	S150	S250
A	219 ±5	323 ±5	406 ±5
C1 (compact)	370 ±5	422 ±5	463 ±5
C2 (remote)	293 ±5	345 ±5	386 ±5
D	160		
E	60		
F	123.5		
G	137		
H	98.5		

	Dimensions [inches]		
	S100	S150	S250
A	8.6 ±0.2	12.7 ±0.2	16 ±0.2
C1 (compact)	14.6 ±0.2	16.6 ±0.2	18.2 ±0.2
C2 (remote)	11.5 ±0.2	13.6 ±0.2	15.2 ±0.2
D	6.3		
E	2.4		
F	4.9		
G	5.4		
H	3.9		

## Flange connections

	Dimension B [mm]		
	S100	S150	S250
<b>PN16</b>			
DN100	1284	-	-
DN150	1284	1581	-
DN200	-	1581	-
DN250	-	-	1960
DN300	-	-	1960
<b>PN40</b>			
DN100	1310	-	-
DN150	1330	1621	-
DN200	-	1647	-
DN250	-	-	2030
DN300	-	-	2050
<b>PN63</b>			
DN100	1336	-	-
DN150	1370	1661	-
DN200	-	1691	-

	Dimension B [mm]		
	S100	S150	S250
DN250	-	-	2070
DN300	-	-	2100
<b>PN100</b>			
DN100	1360	-	-
DN150	1410	1701	-
DN200	-	1731	-
DN250	-	-	1977
DN300	-	-	2160
<b>PN160</b>			
DN100	1380	-	-
DN150	1436	1727	-
DN200	-	1751	-
DN250	-	-	2130
DN300	-	-	2170
<b>ASME 150</b>			
4"	1334	-	-
6"	1358	1649	-
8"	-	1675	-
10"	-	-	2024
12"	-	-	2050
<b>ASME 300</b>			
4"	1352	-	-
6"	1378	1669	-
8"	-	1695	-
10"	-	-	2056
12"	-	-	2082
<b>ASME 600</b>			
4"	1398	-	-
6"	1428	1719	-
8"	-	1751	-
10"	-	-	2138
12"	-	-	2146
<b>ASME 900</b>			
4"	1422	-	-
6"	1474	1765	-
8"	-	1809	-
10"	-	-	2202
12"	-	-	2234
<b>ASME 1500</b>			
4"	1442	-	-
6"	1554	-	-

	Dimension B [mm]		
	S100	S150	S250
8"	-	1911	-
10"	-	-	2400
12"	-	-	2400
<b>JIS 10K</b>			
100A	1332	-	-
<b>JIS 20K</b>			
100A	1332	-	-

	Dimension B [inches]		
	S100	S150	S250
<b>PN16</b>			
DN100	50.5	-	-
DN150	50.5	62.2	-
DN200	-	62.2	-
DN250	-	-	77.2
DN300	-	-	77.2
<b>PN40</b>			
DN100	51.5	-	-
DN150	52.6	64	-
DN200	-	65.5	-
DN250	-	-	80.7
DN300	-	-	82.3
<b>PN63</b>			
DN100	53.2	-	-
DN150	52.3	67	-
DN200	-	65	-
DN250	-	-	84.8
DN300	-	-	81.5
<b>PN100</b>			
DN100	53.9	-	-
DN150	55.5	66.6	-
DN200	-	68.3	-
DN250	-	-	83.5
DN300	-	-	85.9
<b>PN160</b>			
DN100	54.3	-	-
DN150	56.5	68	-
DN200	-	68.9	-
DN250	-	-	83.9
DN300	-	-	85.4

	Dimension B [inches]		
	S100	S150	S250
<b>ASME 150</b>			
4"	52.5	-	-
6"	53.4	65	-
8"	-	66	-
10"	-	-	80.4
12"	-	-	81.5
<b>ASME 300</b>			
4"	53.2	-	-
6"	54.2	65.8	-
8"	-	66.8	-
10"	-	-	81.7
12"	-	-	82.7
<b>ASME 600</b>			
4"	54.9	-	-
6"	56.1	67.8	-
8"	-	68.9	-
10"	-	-	85
12"	-	-	85.2
<b>ASME 900</b>			
4"	55.2	-	-
6"	57.9	69.5	-
8"	-	71.2	-
10"	-	-	87.5
12"	-	-	88.7
<b>ASME 1500</b>			
4"	56.8	-	-
6"	61.2	-	-
8"	-	75.3	-
10"	-	-	94.5
12"	-	-	94.5
<b>JIS 10K</b>			
100A	52.5	-	-
<b>JIS 20K</b>			
100A	52.5	-	-

## 2.4.2 Hygienic versions

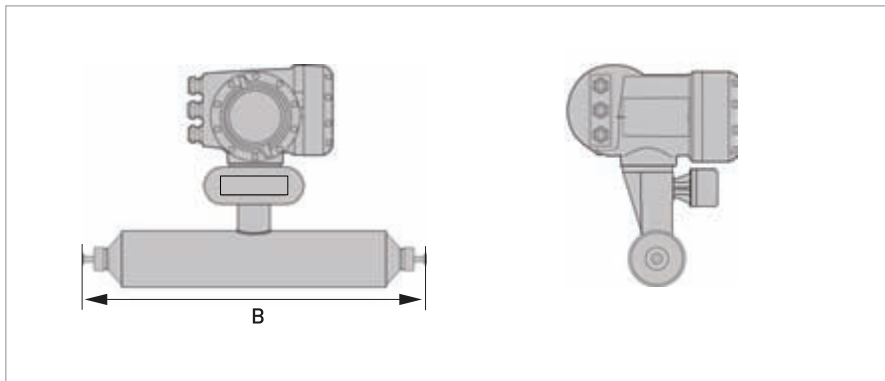

## Hygienic connections: all welded versions

	Dimension B [mm]		
	S100	S150	S250
<b>Tri-clover</b>			
4"	1223	-	-
<b>Tri-clamp DIN 32676</b>			
DN100	1236	-	-
<b>Tri-clamp ISO 2852</b>			
4"	1223	-	-
<b>DIN 11864-2 form A</b>			
DN100	1296	-	-

	Dimension B [inches]		
	S100	S150	S250
<b>Tri-clover</b>			
4"	48	-	-
<b>Tri-clamp DIN 32676</b>			
DN100	48.7	-	-
<b>Tri-clamp ISO 2852</b>			
4"	48	-	-
<b>DIN 11864-2 form A</b>			
DN100	51	-	-

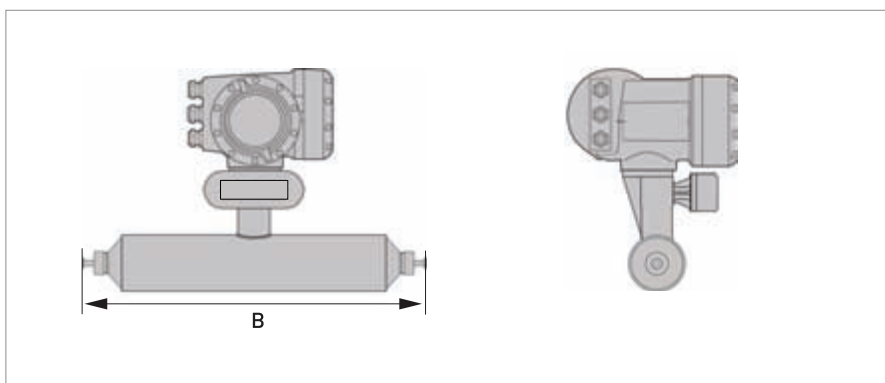

Hygienic connections: adapter versions (male thread)

	Dimension B [mm]		
	S100	S150	S250
<b>Male thread DIN 11851</b>			
DN100	1288	-	-
<b>Male thread SMS</b>			
4"	1236	-	-
<b>Male thread IDF/ISS</b>			
4"	1223	-	-
<b>Male thread RJT</b>			
4"	1234	-	-

	Dimension B [inches]		
	S100	S150	S250
<b>Male thread DIN 11851</b>			
DN100	50.1	-	-
<b>Male thread SMS</b>			
4"	48.7	-	-
<b>Male thread IDF/ISS</b>			
4"	48	-	-
<b>Male thread RJT</b>			
4"	48.6	-	-

## 2.4.3 Heating jacket version

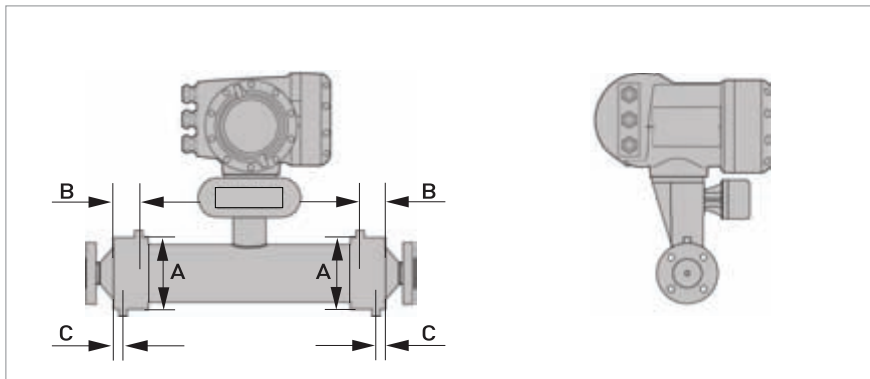

	Dimensions [mm]		
	S100	S150	S250
Heating connection size	25 mm (ERMETO)		
A	254 ±2.5	355 ±2.5	444 ±2.5
B	178 ±2.0	228 ±2.0	208 ±2.0
C	28 ±2.0	28 ±2.0	6.5 ±2.0

	Dimensions [inches]		
	S100	S150	S250
Heating connection size	1" (NPTF)		
A	10 ±0.1	14 ±0.1	17.5 ±0.06
B	7 ±0.08	9 ±0.08	8.2 ±0.08
C	1.1 ±0.08	1.1 ±0.08	0.25 ±0.08

2.4.4 Purge port option

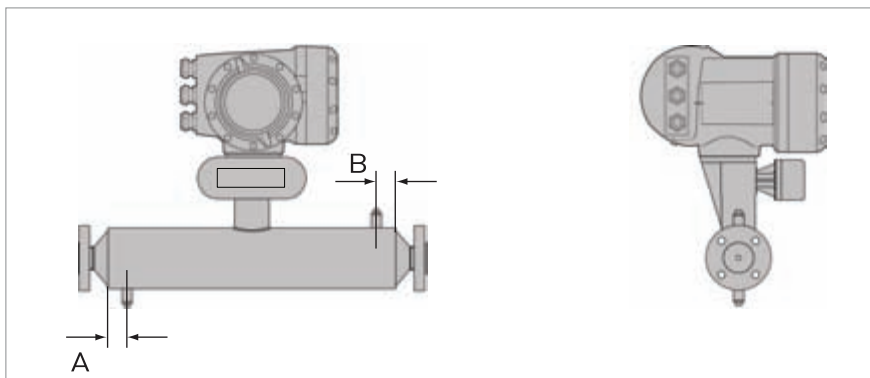

	Dimensions [mm]		
	S100	S150	S250
A	70 ±1.0	100 ±1.0	
B	70 ±1.0	100 ±1.0	

	Dimensions [inches]		
	S100	S150	S250
A	2.75 ±0.04	4.0 ±0.04	
B	2.75 ±0.04	4.0 ±0.04	



## 3.1 Intended use

This mass flowmeter is designed for the direct measurement of mass flow rate, product density and product temperature. Indirectly, it also enables the measurement of parameters like total mass, concentration of dissolved substances and the volume flow. For use in hazardous areas, special codes and regulations are also applicable and these are specified in a separate documentation.

## 3.2 Mounting restrictions

### 3.2.1 General installation principles

**There are no special installation requirements but you should note the following points:**

- Support the weight of the meter.
- The meter can be supported on the sensor body.
- On larger meter sizes and hygienic connections, it is strongly recommended that the meter is not supported solely by the process pipework.
- No straight runs are required.
- The use of reducers and other fittings at flanges, including flexible hoses, is allowed but you should take care to avoid cavitation.
- Avoid extreme pipe size reductions.
- Meters are not affected by crosstalk and can be mounted in series or in parallel.
- Avoid mounting the meter at the highest point in the pipeline where air / gas can collect.

## Mounting positions

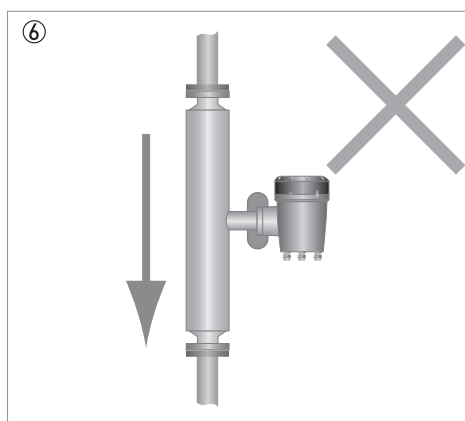
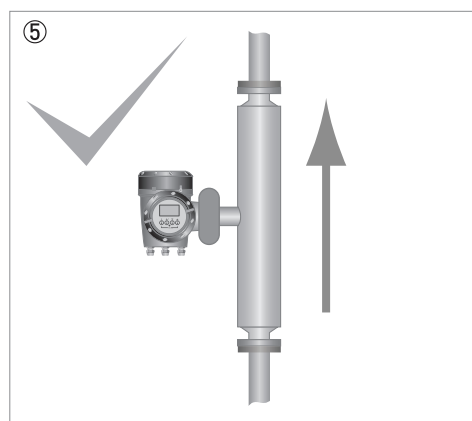
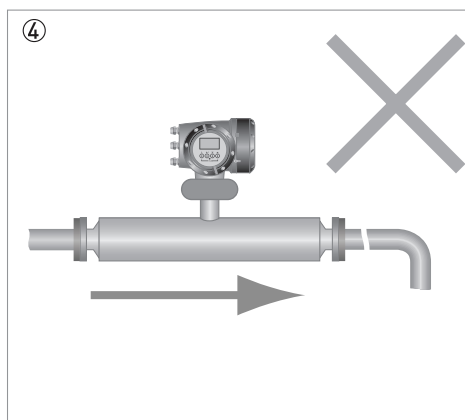
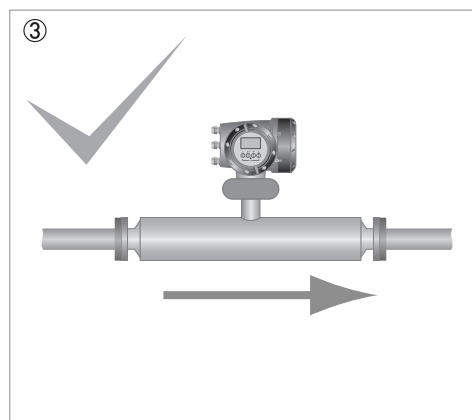
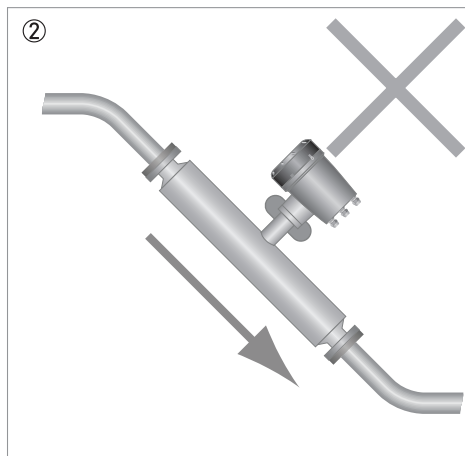
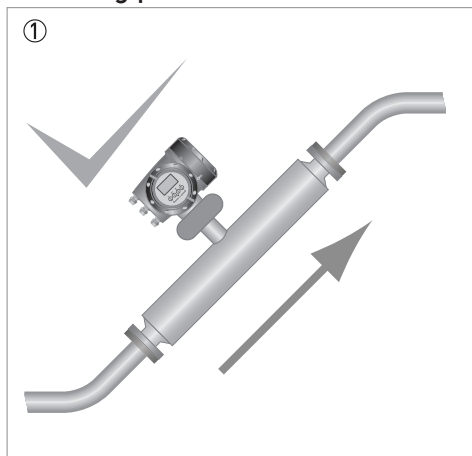

- ① The meter can be mounted at an angle but it is recommended that the flow is uphill.
- ② Avoid mounting the meter with the flow running downhill because it can cause siphoning. If the meter has to be mounted with the flow running downhill, install an orifice plate or control valve downstream of the meter to maintain backpressure.
- ③ Horizontal mounting with flow running left to right.
- ④ Avoid mounting meter with long vertical runs after the meter as it can cause cavitation. Where the installation includes a vertical run after the meter, install an orifice plate or control valve downstream to maintain backpressure.
- ⑤ The meter can be mounted vertically but it is recommended that the flow is uphill.
- ⑥ Avoid mounting the meter vertically with the flow running downhill. This can cause siphoning. If the meter has to be installed this way, install an orifice plate or control valve downstream to maintain backpressure.

### Zero calibration

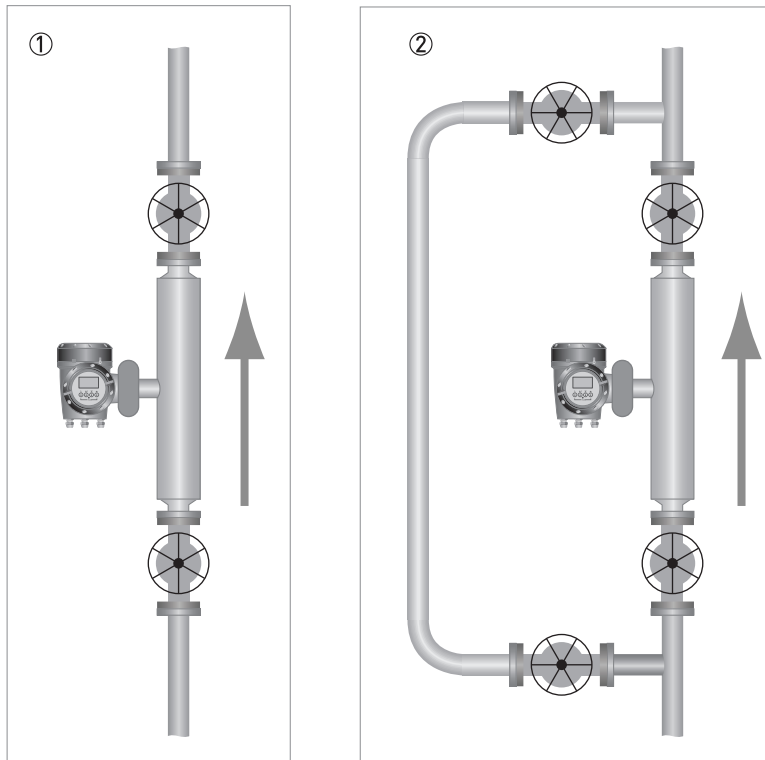

- ① Where the meter has been installed vertically, install shut-off valves either side of the meter to assist with zero calibration.
- ② If the process flow cannot be stopped, install a bypass section for zero calibration.

### 3.2.2 Sunshades

The meter **MUST** be protected from strong sunlight.

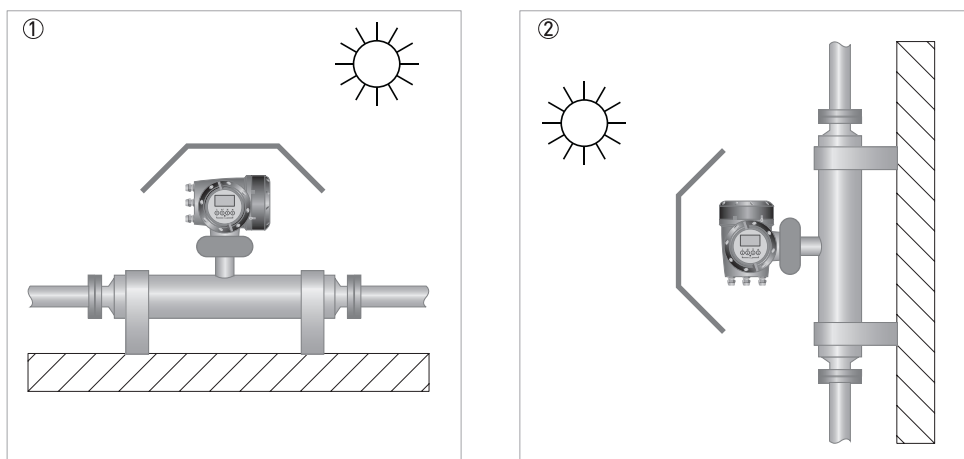

- ① Horizontal installation
- ② Vertical installation

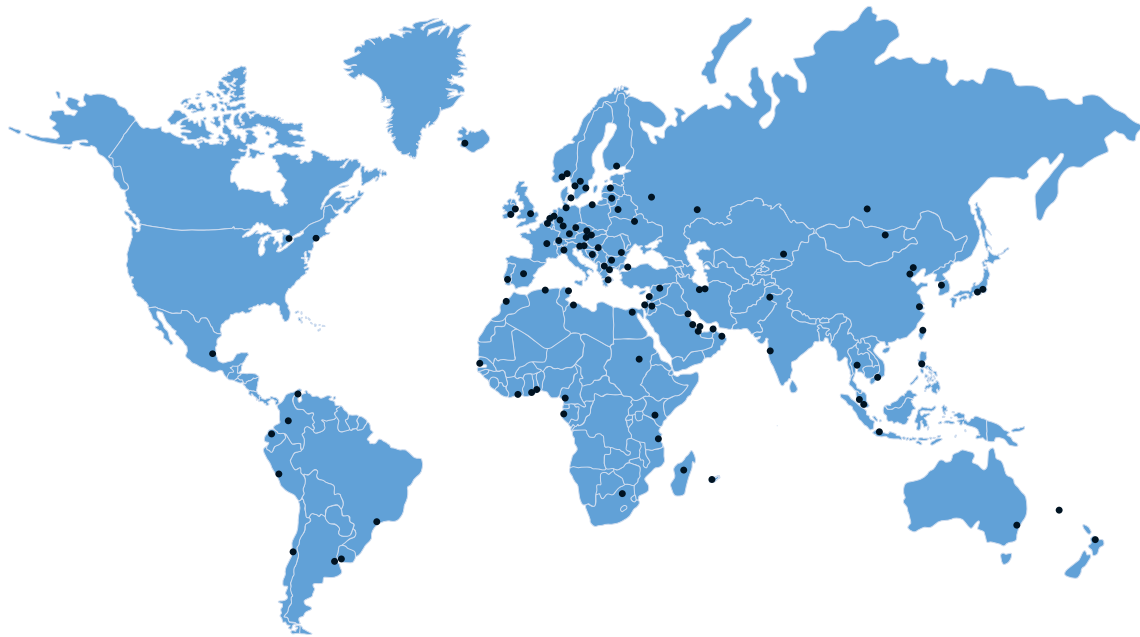

### KROHNE product overview

- Electromagnetic flowmeters
- Variable area flowmeters
- Ultrasonic flowmeters
- Mass flowmeters
- Vortex flowmeters
- Flow controllers
- Level meters
- Temperature meters
- Pressure meters
- Analysis products
- Measuring systems for the oil and gas industry
- Measuring systems for sea-going tankers

Head Office KROHNE Messtechnik GmbH  
Ludwig-Krohne-Str. 5  
D-47058 Duisburg (Germany)  
Tel.: +49 (0)203 301 0  
Fax: +49 (0)203 301 10389  
info@krohne.de

The current list of all KROHNE contacts and addresses can be found at:  
[www.krohne.com](http://www.krohne.com)

**KROHNE**