



## OPTIMASS 7000 Technical Datasheet

### Sensor for mass flow

- The optimum meter for demanding applications
- A single straight measuring tube
- Choice of 4 tube materials



The documentation is only complete when used in combination with the relevant documentation for the converter.

1	Product features	3
<hr/>		
1.1	Overview.....	3
1.2	Features and options.....	5
1.3	Meter / converter combinations.....	6
1.4	Measuring principle (single tube) .....	6
2	Technical data	8
<hr/>		
2.1	Technical data.....	8
2.2	Measuring accuracy .....	14
2.3	Guidelines for maximum operating pressure.....	15
2.4	Dimensions and weights .....	19
2.4.1	Flanged versions.....	19
2.4.2	Hygienic versions .....	22
2.4.3	Heating jacket version .....	28
2.4.4	Purge port option .....	29
3	Installation	30
<hr/>		
3.1	Intended use .....	30
3.2	Mounting restrictions .....	30
3.2.1	General installation principles .....	30
3.2.2	Sunshades.....	32
4	Notes	33
<hr/>		
5	Notes	35
<hr/>		

## 1.1 Overview

The OPTIMASS 7000 is the only sensor for mass flow with a single straight measuring tube that is available in Titanium, Stainless Steel, Hastelloy® or Tantalum.

### Compact version



- ① Comprehensive diagnostic capabilities.
- ② Standard flange and hygienic process connections available.
- ③ Standard electronics for all sensors with redundant storage of calibration and sensor data.
- ④ Modular electronics with a range of output options (see separate documentation for details).

### Remote version



- ① Remote terminal box.

**Highlights**

- Outer cylinder typical burst pressure greater than 100 barg / 1450 psig, with optional PED approved secondary pressure containment available
- Easily drained and easy to clean
- Resistant to installation and process effects
- Excellent zero stability
- Low energy consumption, means lower operating costs
- Rapid signal processing, even with product / temperature changes
- Modular electronics with data redundancy - "plug & play" replacement of electronics

**Industries**

- Water & wastewater
- Mining & building materials
- Iron, steel and metal processing
- Food & beverage
- Oil, gas and alternative fuels
- Paper & pulp
- Petrochemical industry
- Pharmaceutical industry
- Chemical industry

**Applications**

- Viscous or shear-sensitive products
- Products requiring low flow velocities
- Non-homogeneous mixtures
- Products with entrained solids or gas
- Custody transfer
- Loading and product transfer measurement
- Slurries
- Highly corrosive fluids

## 1.2 Features and options

### Features



- Available as compact or remote.
- Low pressure loss - single straight tube design guarantees a low pressure drop across the meter.
- Self Draining.
- Easy to clean.

### Connection options



- A range of flanges up to ASME 600 / PN100.
- Supports a wide range of industry standard hygienic connections.
- Adaptable to suit customer's hygienic connections.

### Heating jacket and purge port



- Heating jacket option for use with temperature dependant products.
- Prevents solidification of process product.
- Purge port option for protection in the event of measuring tube failure.
- Allows hazardous chemicals to be drained away safely.
- Can also be used for the early detection of measuring tube failure where highly toxic chemicals are being measured.

### 1.3 Meter / converter combinations

Converter	MFC 010	MFC 300			
Configuration	Compact	Compact	Remote field	Remote wall	Remote rack
OPTIMASS 7000	7010C	7300C	7300F	7300W	7300R

### 1.4 Measuring principle (single tube)

Static meter not energised and with no flow

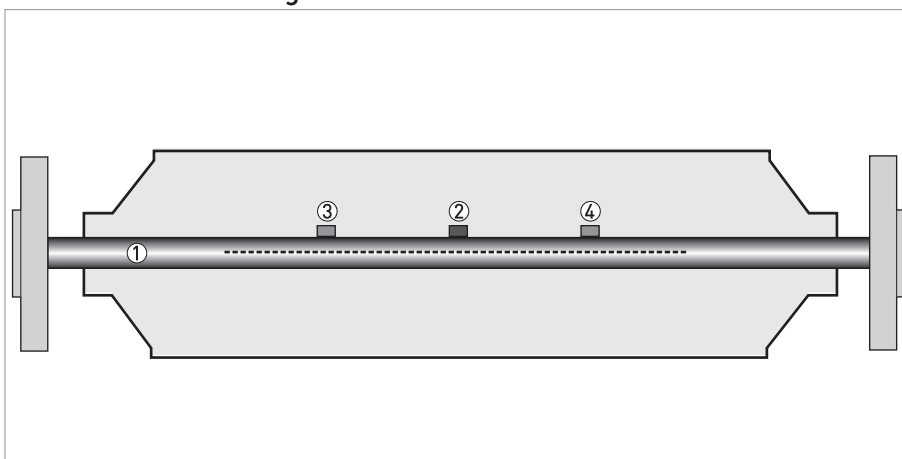

- ① Measuring tube
- ② Drive coil
- ③ Sensor 1
- ④ Sensor 2

A Coriolis single tube mass flowmeter consists of a single measuring tube (1) a drive coil (2) and two sensors (3 and 4) that are positioned either side of the drive coil.

Energised meter

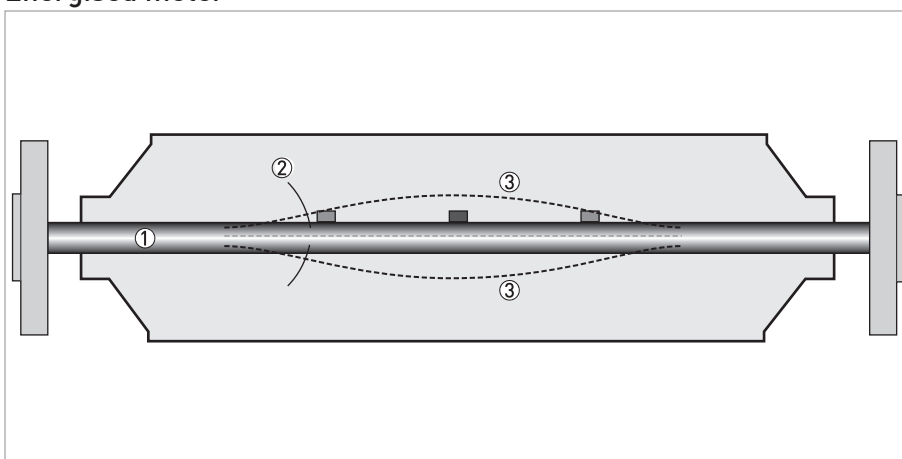

- ① Measuring tubes
- ② Direction of oscillation
- ③ Sine wave

When the meter is energised, the drive coil vibrates the measuring tube causing it to oscillate and produce a sine wave (3). The sine wave is monitored by the two sensors.

### Energised meter with process flow

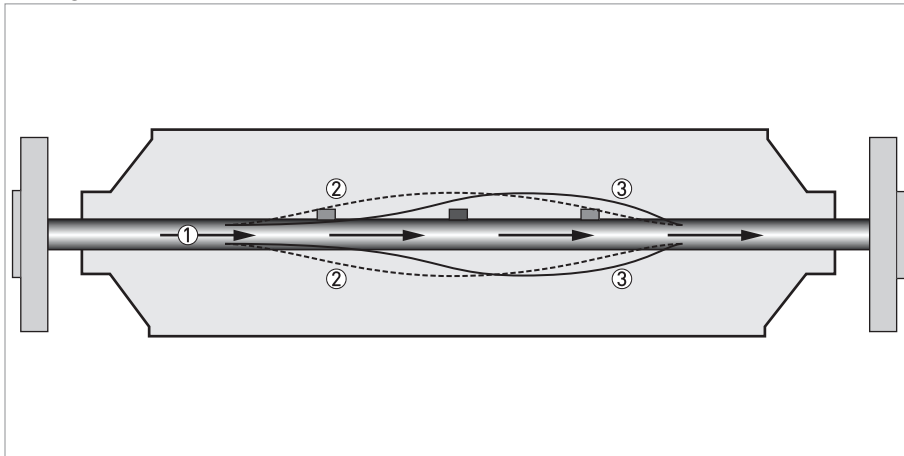

- ① Process flow
- ② Sine wave
- ③ Phase shift

When a fluid or gas passes through the tube, the coriolis effect causes a phase shift in the sine wave that is detected by the two sensors. This phase shift is directly proportional to the mass flow.

Density measurement is made by evaluation of the frequency of vibration and temperature measurement is made using a Pt500 sensor.

## 2.1 Technical data

- *The following data is provided for general applications. If you require data that is more relevant to your specific application, please contact us or your local representative.*
- *Additional information (certificates, special tools, software,...) and complete product documentation can be downloaded free of charge from the website (Downloadcenter).*

### Measuring system

Measuring principle	Coriolis mass flow
Application range	Mass flow and density measurement of fluids, gases and solids
Measured values	Mass, density, temperature
Calculated values	Volume, referred density, concentration, velocity

### Design

Basic	System consists of a measuring sensor and a converter to process the output signal
Features	Fully welded maintenance free sensor with single straight measuring tube
<b>Variants</b>	
Compact version	Integral converter
Remote version	Available with field, wall or 19" rack mount versions of the converter
Modbus version	Sensor with integral electronics providing Modbus output for connection to a PLC

### Measuring accuracy

<b>Mass</b>	
Liquid	±0.1% of actual measured flow rate + zero stability
Gas	±0.5% of actual measured flow rate + zero stability
Repeatability	Better than 0.05% plus zero stability (includes the combined effects of repeatability, linearity and hysteresis)
<b>Zero stability</b>	
Titanium	±0.004% of maximum flow rate with respective sensor size
Stainless Steel / Hastelloy® / Tantalum	±0.015% of maximum flow rate with respective sensor size
<b>Reference conditions</b>	
Product	Water
Temperature	+20°C / +68°F
Operating pressure	1 barg / 14.5 psig
<b>Effect on sensor zero point caused by a shift in process temperature</b>	
Titanium	0.001% per 1°C / 0.00055% per 1°F
Stainless Steel / Hastelloy® / Tantalum	0.004% per 1°C / 0.0022% per 1°F
<b>Effect on sensor zero point caused by a shift in process pressure</b>	
Titanium / Stainless Steel / Hastelloy® / Tantalum	0.0011% of the max flow rate per 1 bar <sub>rel.</sub> / 0.000076% per 1 psig



<b>Density</b>	
Measuring range	400...2500 kg/m <sup>3</sup> / 25...155 lbs/ft <sup>3</sup>
Accuracy	±2 kg/m <sup>3</sup> / ±0.13 lbs/ft <sup>3</sup>
On site calibration	±0.5 kg/m <sup>3</sup> / ±0.033 lbs/ft <sup>3</sup>
<b>Temperature</b>	
Accuracy	±1°C / ±1.8°F

### Operating conditions

<b>Maximum flow rates</b>	
06	1230 kg/h / 35 lbs/min
10	3500 kg/h / 100 lbs/min
15	14600 kg/h / 400 lbs/min
25	44800 kg/h / 1250 lbs/min
40	120000 kg/h / 3300 lbs/min
50	234000 kg/h / 6600 lbs/min
80	560000 kg/h / 15800 lbs/min
<b>Ambient temperature</b>	
Compact version with Aluminium converter	-40...+60°C / -40...+140°F Extended temperature range +65°C / +149°F for some I/O options. For more information contact manufacturer
Compact version with Stainless Steel converter	-40...+55°C / -40...+130°F
Remote versions	-40...+65°C / -40...+149°F
<b>Process temperature</b>	
Titanium	-40...+150°C / -40...+302°F
Stainless Steel	0...+100°C / 32...+212°F Extended temperature range 0...+130°C / 32...+266°F on Stainless Steel, sizes 25...80, hygienic connections only
Hastelloy®	0...+100°C / 32...+212°F
Tantalum	0...+100°C / 32...+212°F
<b>Nominal pressure at 20°C / 68°F</b>	
<b>Measuring tube</b>	
Titanium	-1...100 barg / -14.5...1450 psig
Stainless Steel / Hastelloy® / Tantalum	-1...50 barg / -14.5...725 psig
<b>Outer cylinder</b>	
Non PED / CRN approved	Typical burst pressure > 100 barg / 1450 psig at 20°C
PED / CRN approved secondary containment	-1...63 barg / -14.5...910 psig
PED approved secondary containment	-1...100 barg / -14.5...1450 psig
<b>Fluid properties</b>	
Permissible physical condition	Liquids, gases, slurries
Permissible gas content (volume)	Contact manufacturer for information
Permissible solid content (volume)	Contact manufacturer for information
<b>Other operating conditions</b>	
Protection category (acc. to EN 60529)	IP 67, NEMA 4X

**Installation conditions**

Inlet runs	None required
Outlet runs	None required

**Materials**

<b>Titanium meter</b>	
Measuring tube / raised faces	Titanium grade 9 / grade 2
Flanges	Stainless Steel 316 / 316L (1.4401 / 1.4404) dual certified
Outer cylinder	Stainless Steel 304 / 304L (1.4301 / 1.4307) dual certified
	Optional Stainless Steel 316 / 316L (1.4401 / 1.4404) dual certified
<b>Stainless Steel meter</b>	
Measuring tube / raised faces	Stainless Steel UNS S31803 (1.4462)
Flanges	Stainless Steel 316 / 316L (1.4401 / 1.4404) dual certified
Outer cylinder	Stainless Steel 304 / 304L (1.4301 / 1.4307) dual certified
	Optional Stainless Steel 316 / 316L (1.4401 / 1.4404) dual certified
<b>Hastelloy® meter</b>	
Measuring tube / raised faces	Hastelloy® C-22
Flanges	Stainless Steel 316 / 316L (1.4401 / 1.4404) dual certified
Outer cylinder	Stainless Steel 304 / 304L (1.4301 / 1.4307) dual certified
	Optional Stainless Steel 316 / 316L (1.4401 / 1.4404) dual certified
<b>Tantalum meter</b>	
Measuring tube / raised faces	Tantalum Ta 10W
Flanges	Stainless Steel 316 / 316L (1.4401 / 1.4404) dual certified
Outer cylinder	Stainless Steel 316 / 316L (1.4401 / 1.4404) dual certified
<b>Heating jacket version</b>	
Heating jacket	Stainless Steel 316L (1.4404)
	The outer cylinder is in contact with the heating medium
<b>All versions</b>	
Sensor electronics housing	Stainless Steel 316L (1.4409)
Junction box (remote version)	Die cast Aluminium (polyurethane coating)
	Optional Stainless Steel 316L (1.4401)

**Process connections**

<b>Flange</b>	
DIN	DN10...100 / PN40...100
ASME	½...4" / ASME 150...600
JIS	10...100A / 10...20K
<b>Hygienic</b>	
Tri-clover	½...4"
Tri-clamp DIN 32676	DN10...80
Tri-clamp ISO 2852	1½...4"
DIN 11864-2 Form A	DN10...80
Male thread DIN 11851	DN10...80

Male thread SMS	1...3"
Male thread IDF / ISS	1...3"
Male thread RJT	1...3"

### Electrical connections

Electrical connections	For full details, including power supply, power consumption etc., see technical data for the relevant converter
I/O	For full details of I/O options including data streams and protocols, see technical data for the relevant converter

### Approvals and certifications

<b>Mechanical</b>	
Electromagnetic compatibility (EMC) acc. to CE	Namur NE 21/5.95
	89/336/EEC (EMC)
	72/73/EEC (Low Voltage Directive)
European Pressure Equipment Directive	PED 97-23 EC (acc. to AD 2000 Regelwerk)
Factory Mutual / CSA	Class I, Div 1 groups B, C, D
	Class II, Div 1 groups E, F, G
	Class III, Div 1 hazardous areas
	Class I, Div 2 groups B, C, D
	Class II, Div 2 groups F, G
	Class III, Div 2 hazardous areas
ANSI / CSA (Dual Seal)	12.27.901-2003
Hygienic	3A 28-03
	EHEDG
	ASME BPE
Custody transfer	MID 2004/22/EC MI-005
<b>ATEX (acc. 94/9/EC)</b>	
<b>OPTIMASS 7300C non Ex I signal outputs without heating jacket / insulation</b>	
Ex d connection compartment	II 2 G Ex d [ib] IIC T6...T1
	II 2 D Ex tD A21 IP6x T160°C
Ex e connection compartment	II 2 G Ex de [ib] IIC T6...T1
	II 2 D Ex tD A21 IP6x T160°C
<b>OPTIMASS 7300C non Ex I signal outputs with heating jacket / insulation</b>	
Ex d connection compartment	II 2 G Ex d [ib] IIC T6...T1
	II 2 D Ex tD A21 IP6x T170°C
Ex e connection compartment	II 2 G Ex de [ib] IIC T6...T1
	II 2 D Ex tD A21 IP6x T170°C
<b>OPTIMASS 7300C Ex I signal outputs without heating jacket / insulation</b>	
Ex d connection compartment	II 2(1) G Ex d [ia/ib] IIC T6...T1
	II 2(1) D Ex tD [iaD] A21 IP6x T160°C
Ex e connection compartment	II 2(1) G Ex de [ia/ib] IIC T6...T1
	II 2(1) D Ex tD [iaD] A21 IP6x T160°C

OPTIMASS 7300C Ex I signal outputs with heating jacket / insulation	
Ex d connection compartment	II 2(1) G Ex d [ia/ib] IIC T6...T1
	II 2(1) D Ex tD [iaD] A21 IP6x T170°C
Ex e connection compartment	II 2(1) G Ex de [ia/ib] IIC T6...T1
	II 2(1) D Ex tD [iaD] A21 IP6x T170°C
OPTIMASS 7000 / 7010C without heating / insulation	II 2 G Ex ib IIC T6...T1
	II 2 D Ex ibD 21 T150 °C
OPTIMASS 7000 / 7010C with heating / insulation	II 2 G Ex ib IIC T6...T1
	II 2 D Ex ibD 21 T165 °C

## ATEX (acc. 94/9/EC) temperature limits

	Ambient temp. $T_{amb}$ °C	Max. medium temp. $T_m$ °C	Temp. class	Max. surface temp. °C
OPTIMASS 7000 / 7010C - no heating jacket / insulation	40	70	T6	T80
		90	T5	T95
		130	T4	T130
		150	T3 – T1	T150
	50	70	T6	T80
		85	T5	T95
		130	T4	T130
		150	T3 – T1	T150
	65	85	T5	T95
		125	T4	T130
		150	T3 – T1	T150
	OPTIMASS 7000 / 7010C - heating jacket / insulation	40	65	T6
80			T5	T95
115			T4	T130
150			T3 – T1	T165
65		80	T5	T95
		115	T4	T130
		150	T3 – T1	T165
OPTIMASS 7300C - Aluminium converter housing - no heating jacket / insulation	40	55	T6	T80
		75	T5	T95
		120	T4	T130
		150	T3 - T1	T160
	50	75	T5	T95
		115	T4	T130
		150	T3 - T1	T160
	60	60	T4 - T1	T85
	65 ①	65	T4 - T1	T90

	Ambient temp. $T_{amb}$ °C	Max. medium temp. $T_m$ °C	Temp. class	Max. surface temp. °C
OPTIMASS 7300C- Aluminium converter housing - heating jacket / insulation	40	55	T6	T80
		70	T5	T95
		100	T4	T125
		145	T3 - T1	T170
	50	70	T4	T95
		100	T3 - T1	T125
	60	60	T4 - T1	T85
65 ①	65	T4 - T1	T90	
OPTIMASS 7300C - Stainless Steel converter housing - no heating jacket / insulation	40	55	T6	T80
		75	T5	T95
		120	T4	T130
		150	T3 - T1	T160
	50	75	T5	T95
		115	T4	T130
		135	T3 - T1	T145
55	55	T4 - T1	T80	
OPTIMASS 7300C - Stainless Steel converter housing - heating jacket / insulation	40	55	T6	T80
		70	T5	T95
		100	T4	T125
		145	T3 - T1	T170
	50	70	T4	T95
		35	T3 - T1	T100
	55	55	T4 - T2	T80

① depending on I/O option. Please call for more information.

### Maximum end loadings

Size	06	10	15	25	40	50	80
<b>Titanium</b>							
Flanges	19kN	25kN	38kN	60kN	80kN	170kN	230kN
Hygienic (all connections)	1.5kN	2kN	5kN	9kN	12kN	12kN	30kN
<b>Stainless Steel / Hastelloy® / Tantalum</b>							
Flanges	19kN	25kN	38kN	60kN	80kN	80kN	170kN
Hygienic (all connections)	1.5kN	2kN	5kN	9kN	12kN	12kN	18kN

## 2.2 Measuring accuracy

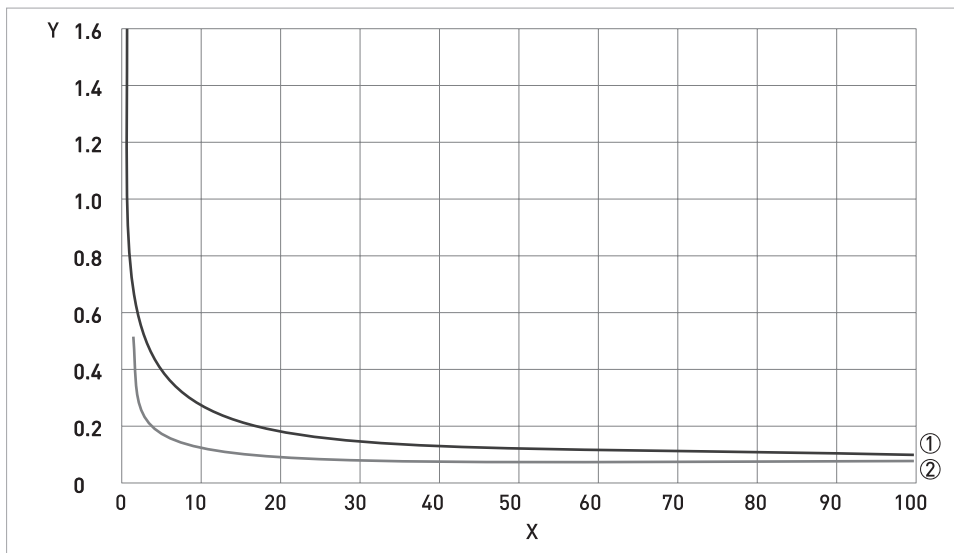

X flow rate [%]  
 Y measuring error [%]

- ① Stainless Steel, Hastelloy® and Tantalum
- ② Titanium

### Measuring error

The measuring error is obtained from the combined effects of accuracy and zero stability.

### Reference conditions

Product	Water
Temperature	+20°C / +68°F
Operating pressure	1 barg / 14.5 psig

## 2.3 Guidelines for maximum operating pressure

### Notes

- Ensure that the meter is used within its operating limits
- All hygienic process connections have a maximum operating rating of 10 barg at 130°C / 145 psig at 266°F

### Pressure / temperature de-rating for Titanium Gr 9 meters (all meter sizes, with flanged connections as per EN 1092-1)

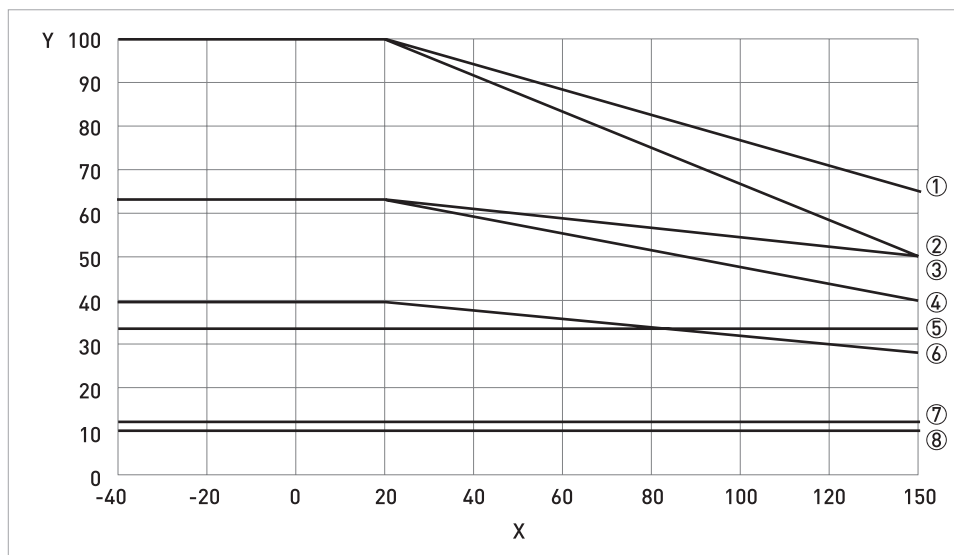

X temperature [°C]

Y pressure [barg]

- ① Standard tube and outer cylinder 316L (100 barg PED option) with PN100 flanges (sizes DN06...25)
- ② Standard tube and outer cylinder 316L (100 barg PED option) with PN100 flanges (sizes DN40...80)
- ③ DIN 2637 PN63 flanges
- ④ Outer cylinder 304 (63 barg PED / CRN option)
- ⑤ JIS 20K flanges
- ⑥ DIN 2635 PN40 flanges
- ⑦ JIS 10K flanges
- ⑧ Hygienic connections

**Pressure / temperature de-rating for Titanium Gr 9 meters  
(all meter sizes with flanged connections as per ASME B16.5)**

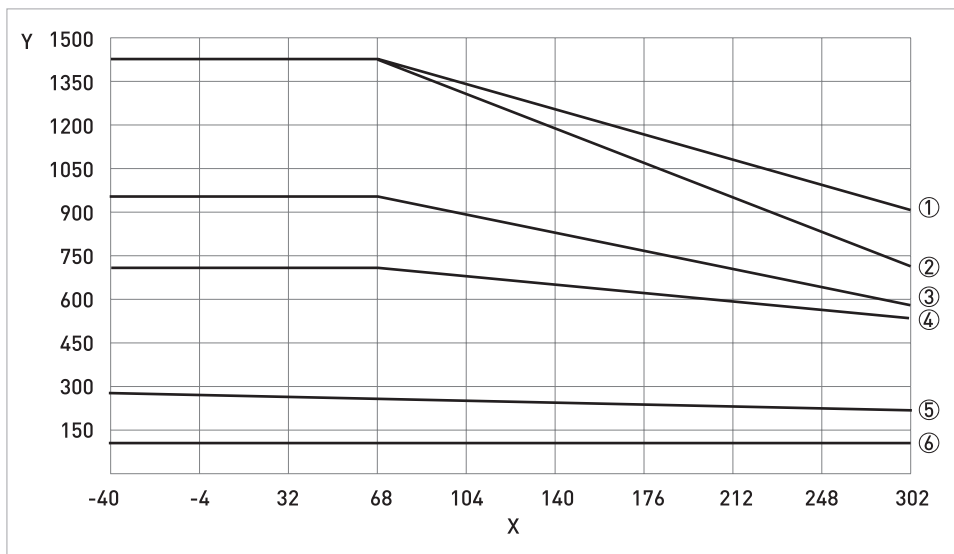

X temperature [°F]  
Y pressure [psig]

- ① Standard tube and outer cylinder 316L (100 barg PED option) with ASME 600 lbs flanges (sizes DN06...25)
- ② Standard tube and outer cylinder 316L (100 barg PED option) with ASME 600 lbs flanges (sizes DN40...80)
- ③ Outer cylinder 304 (63 barg PED / CRN option)
- ④ ASME 300 lbs
- ⑤ ASME 150 lbs
- ⑥ Hygienic connections



**Pressure / temperature de-rating for Stainless Steel, Hastelloy® C22 and Tantalum meters (all meter sizes with flanged connections as per EN 1092-1)**

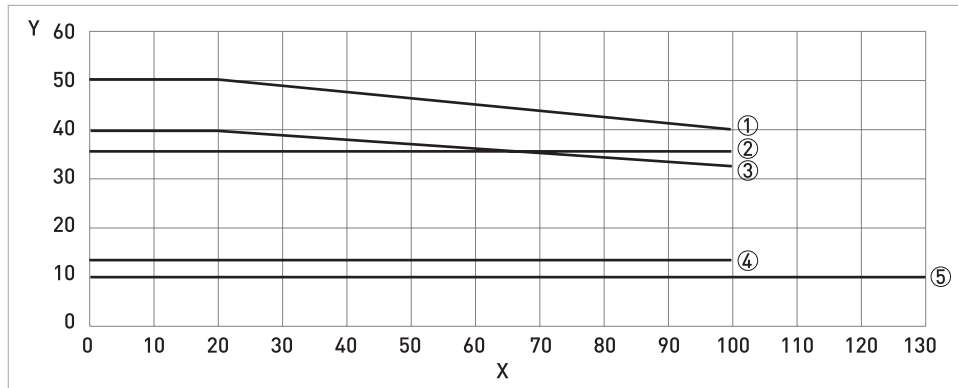

X temperature [°C]

Y pressure [barg]

- ① Standard tubes and outer cylinder 304 (all sizes) (63 barg PED / CRN option)
- ② JIS 20K flanges
- ③ DIN 2635 PN40 flanges
- ④ JIS 10K flanges
- ⑤ Hygienic connections (extended temperature option, Stainless Steel only)

### Pressure / temperature de-rating for Stainless Steel, Hastelloy® C22 and Tantalum meters (all meters with flanged connections as per ASME B16.5)

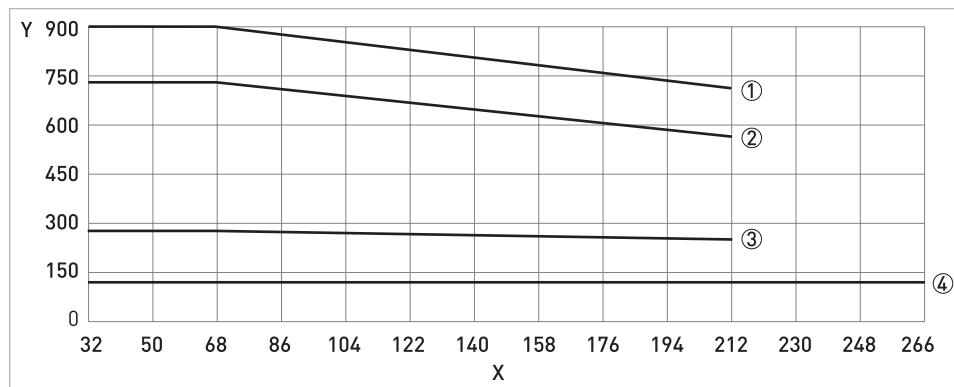

X temperature [°F]

Y pressure [psig]

- ① Outer cylinder (all sizes) (63 barg PED / CRN option)
- ② ASME 300 lbs
- ③ ASME 150 lbs
- ④ Hygienic connections (extended temperature option, Stainless Steel only)

#### Flanges

- DIN flange ratings are based on EN 1092-1 2001 table 18, 1% proof stress material group 14EO
- ASME flange ratings are based on ASME B16.5 2003 table 2 material group 2.2
- JIS flange ratings are based on JIS 2220: 2001 table 1 division 1 material group 022a

#### Notes

- The maximum operating pressure will be either the flange rating or the measuring tube rating, **WHICHEVER IS THE LOWER!**
- The manufacturer recommends that the seals are replaced at regular intervals. This will maintain the hygienic integrity of the connection.

## 2.4 Dimensions and weights

### 2.4.1 Flanged versions

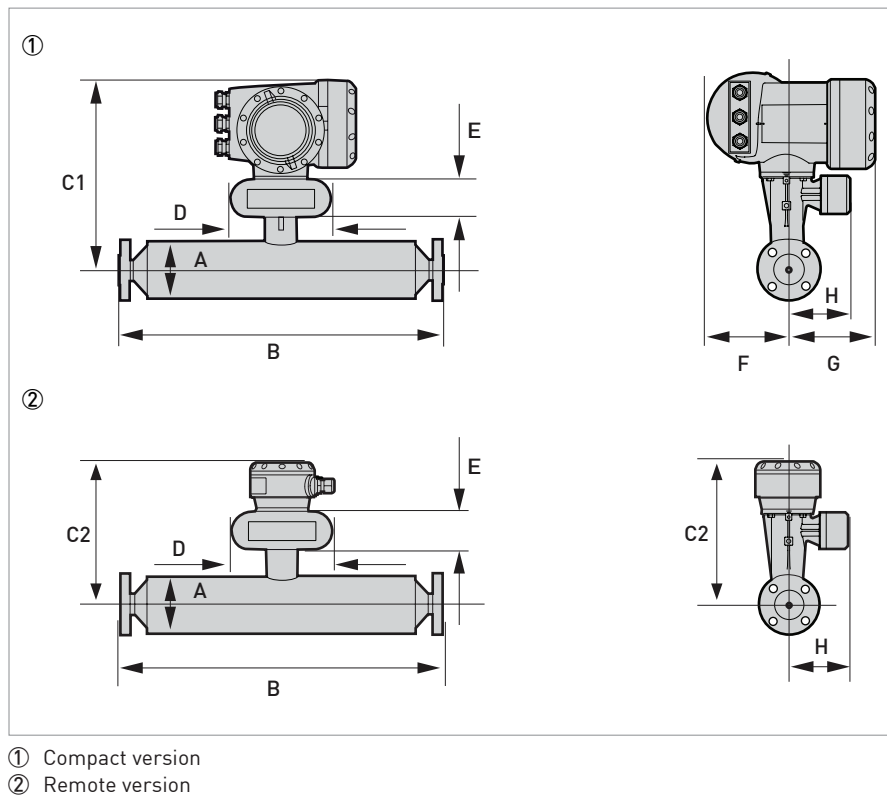

### Meter weights for Titanium (T), Stainless Steel (S), Hastelloy® (H) and Tantalum (A)

	Weight [kg]						
	T/S 06	T/S/H 10	T/S/H/A 15	T/S/H/A 25	T/S/H/A 40	T/S/H/A 50	T/S/H 80
Aluminium (compact)	18.5	23	26	37	83	147	265
Stainless Steel (compact)	25.2	29.7	32.7	43.7	89.7	153.7	271.7
Aluminium (remote)	15.7	20.2	23.2	34.2	80.2	144.2	262.2
Stainless Steel (remote)	16.5	21	24	35	81	145	263
Tantalum add	-	-	2.7	4.5	9.2	15.1	-

	Weight [lbs]						
	T/S 06	T/S/H 10	T/S/H/A 15	T/S/H/A 25	T/S/H/A 40	T/S/H/A 50	T/S/H 80
Aluminium (compact)	40.7	50.6	57.2	81.4	182.6	323.4	583
Stainless Steel (compact)	55.4	65.3	71.9	96.1	197.3	338.1	597.7
Aluminium (remote)	34.5	44.4	51	75.2	176.4	317.2	576.8
Stainless Steel (remote)	36.3	46.2	52.8	77	178.2	319	578.6
Tantalum add	-	-	5.9	9.9	20.2	33.2	-

## Measuring tube in Titanium (T), Stainless Steel (S) or Hastelloy® (H)

	Dimensions [mm]						
	T/S 06	T/S/H 10	T/S/H 15	T/S/H 25	T/S/H 40	T/S/H 50	T/S/H 80
A	102			115	170	220	274
B (standard flange)	420 ±2	510 ±2	548 ±2	700 ±2	925 ±2	1101 ±2	1460 ±4
B (ASME flange 600 lbs)	428 ±2	518 ±2	556 ±2	708 ±2	933 ±2	1109 ±2	1468 ±4
C1 (compact)	311			318	345	370	397
C2 (remote)	231 ±2			237 ±2	265 ±2	290 ±2	317 ±4
D	160						
E	60						
F	123.5						
G	137						
H	98.5						

	Dimensions [inches]						
	T/S 06	T/S/H 10	T/S/H 15	T/S/H 25	T/S/H 40	T/S/H 50	T/S/H 80
A	4			4.5	6.7	8.7	10.8
B (standard flange)	16.5± 0.08	20 ±0.08	21.6 ±0.08	27.5 ±0.08	36.4 ±0.08	43.3 ±0.08	57.5 ±0.16
B (ASME flange 600 lbs)	16.8 ±0.08	20.4±0.08	21.9 ±0.08	27 ±0.08	36.7±0.08	43.3 ±0.08	57.8 ±0.16
C1 (compact)	12.2			12.5	13.6	14.6	15.6
C2 (remote)	9 ±0.08			9.3 ±0.08	10.4 ±0.08	11.4 ±0.08	12.5 ±0.16
D	6.3						
E	2.4						
F	4.9						
G	5.4						
H	3.9						

## Measuring tube in Tantalum (A)

	Dimensions [mm]			
	A 15	A 25	A 40	A 50
A	102	115	170	220
B (standard flange)	633 ±2	800 ±2	1075 ±2	1281 ±2
C1 (compact)	311	318	345	370
C2 (remote)	231 ±2	237 ±2	265 ±2	290 ±2
D	160			
E	60			
F	123.5			
G	137			
H	98.5			

	Dimensions [inches]			
	A 15	A 25	A 40	A 50
A	4	4.5	6.7	8.7
B (standard flange)	21.6 ±0.08	27.5 ±0.08	36.4 ±0.08	43.3 ±0.08
C1 (compact)	12.2	12.5	13.6	14.6
C2 (remote)	9 ±0.08	9.3 ±0.08	10.4 ±0.08	11.4 ±0.08
D	6.3			
E	2.4			
F	4.9			
G	5.4			
H	3.9			

## 2.4.2 Hygienic versions

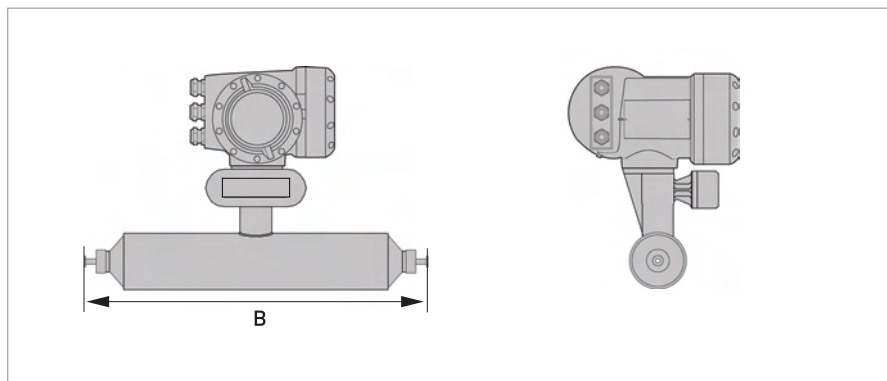

## Hygienic connections: all welded versions

	Dimension B [mm]						
	T/S 06	T/S 10	T/S 15	T/S 25	T/S 40	T/S 50	T/S 80
<b>Tri-clover</b>							
1/2"	480 ±2	558 ±2	-	-	-	-	-
3/4"	-	-	596 ±2	-	-	-	-
1 1/2"	-	-	-	816 ±2	-	--	-
2"	-	-	-	-	1043	-	-
3"	-	-	-	-	-	1305 ±2	-
4"	-	-	-	-	-	-	1527 ±2
<b>Tri-clamp DIN 32676</b>							
DN10	484 ±2	564 ±2	-	-	-	-	-
DN15	-	-	602 ±2	-	-	-	-
DN25	-	-	-	761 ±2	-	-	-
DN40	-	-	-	-	986 ±2	-	-
DN50	-	-	-	-	-	1168 ±2	-
DN80	-	-	-	-	-	-	1584 ±2
<b>Tri-clamp ISO 2852</b>							
1 1/2"	-	-	-	816 ±2	-	-	-
2"	-	-	-	-	1043 ±2	-	-
3"	-	-	-	-	-	1305 ±2	-
4"	-	-	-	-	-	-	1527 ±2
<b>DIN 11864-2 form A</b>							
DN10	-	528 ±2	-	-	-	-	-
DN15	-	-	566 ±2	-	-	-	-
DN25	-	-	-	718 ±2	-	-	-
DN40	-	-	-	-	948 ±2	-	-
DN50	-	-	-	-	-	1124 ±2	-
DN80	-	-	-	-	-	-	1538 ±2

	Dimension B [inches]						
	T/S 06	T/S 10	T/S 15	T/S 25	T/S 40	T/S 50	T/S 80
<b>Tri-clover</b>							
1/2"	18.9 ±0.08	22 ±0.08	-	-	-	-	-
3/4"	-	-	23.5 ±0.08	-	-	-	-
1 1/2"	-	-	-	32.1 ±0.08	-	-	-
2"	-	-	-	-	41 ±0.08	-	-
3"	-	-	-	-	-	51.4 ±0.08	-
4"	-	-	-	-	-	-	49.5 ±0.08
<b>Tri-clamp DIN 32676</b>							
DN10	19 ±0.08	22.2 ±0.08	-	-	-	-	-
DN15	-	-	23.7 ±0.08	-	-	-	-
DN25	-	-	-	30 ±0.08	-	-	-
DN40	-	-	-	-	38.8 ±0.08	-	-
DN50	-	-	-	-	-	46 ±0.08	-
DN80	-	-	-	-	-	-	62.4 ±0.08
<b>Tri-clamp ISO 2852</b>							
1 1/2"	-	-	-	32.2 ±0.08	-	-	-
2"	-	-	-	-	41.1 ±0.08	-	-
3"	-	-	-	-	-	51.4 ±0.08	-
4"	-	-	-	-	-	-	60.1 ±0.08
<b>DIN 11864-2 form A</b>							
DN10	-	20.8 ±0.08	-	-	-	-	-
DN15	-	-	22.3 ±0.08	-	-	-	-
DN25	-	-	-	28.3 ±0.08	-	-	-
DN40	-	-	-	-	37.3 ±0.08	-	-
DN50	-	-	-	-	-	44.3 ±0.08	-
DN80	-	-	-	-	-	-	60.5 ±0.08

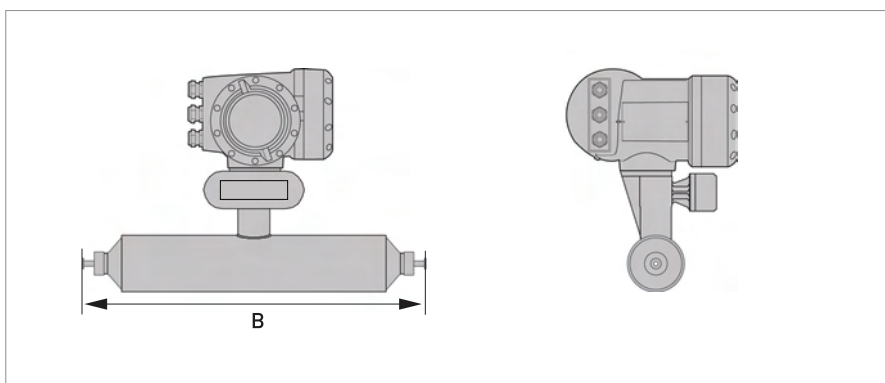

Hygienic connections: adapter versions (Tri-Clover & Tri-clamp)

	Dimension B [mm]				
	T/S 10	T/S 15	T/S 25	T/S 40	T/S 50
<b>Tri-clover</b>					
1/2"	597 ±2	-	-	-	-
3/4"	-	635 ±2	-	-	-
1"	-	665 ±2	-	-	-
1 1/2"	-	-	855 ±2	-	-
2"	-	-	-	1077 ±2	-
3"	-	-	-	-	1355 ±2
<b>Tri-clamp DIN 32676</b>					
DN10	590 ±2	-	-	-	-
DN15	-	628 ±2	-	-	-
DN25	-	-	787 ±2	-	-
DN40	-	-	-	1017 ±2	-
DN50	-	-	-	-	1193 ±2
<b>Tri-clamp ISO 2852</b>					
1"	-	665 ±2	-	-	-
1 1/2"	-	-	855 ±2	-	-
2"	-	-	-	1077 ±2	-
3"	-	-	-	-	1355 ±2



	Dimension B [inches]				
	T/S 10	T/S 15	T/S 25	T/S 40	T/S 50
<b>Tri-clover</b>					
1/2"	23.5 ±0.08	-	-	-	-
3/4"	-	25 ±0.08	-	-	-
1"	-	26.2 ±0.08	-	-	-
1 1/2"	-	-	33.7 ±0.08	-	-
2"	-	-	-	42.4 ±0.08	-
3"	-	-	-	-	53.3 ±0.08
<b>Tri-clamp DIN 32676</b>					
DN10	23.2 ±0.08	-	-	-	-
DN15	-	24.7 ±0.08	-	-	-
DN25	-	-	31 ±0.08	-	-
DN40	-	-	-	40 ±0.08	-
DN50	-	-	-	-	47 ±0.08
<b>Tri-clamp ISO 2852</b>					
1"	-	26.2 ±0.08	-	-	-
1 1/2"	-	-	33.7 ±0.08	-	-
2"	-	-	-	42.4 ±0.08	-
3"	-	-	-	-	53.3 ±0.08

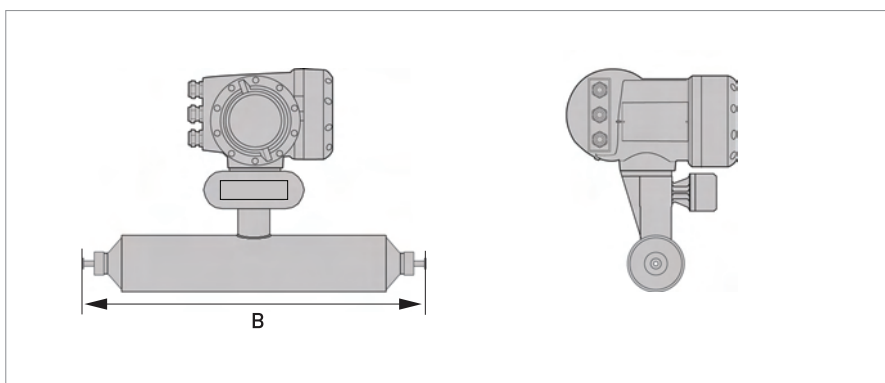

Hygienic connections: adapter versions (male thread)

	Dimension B [mm]					
	T/S 10	T/S 15	T/S 25	T/S 40	T/S 50	T/S 80
<b>Male thread DIN 11851</b>						
DN10	596 ±2	-	-	-	-	-
DN15	-	634 ±2	-	-	-	-
DN25	-	-	802 ±2	-	-	-
DN40	-	-	-	1040 ±2	-	-
DN50	-	-	-	-	1220 ±2	-
DN80	-	-	-	-	-	1658 ±2
<b>Male thread SMS</b>						
1"	-	665 ±2	-	-	-	-
1½"	-	-	852 ±2	-	-	-
2"	-	-	-	1074 ±2	-	-
3"	-	-	-	-	1360 ±2	-
<b>Male thread IDF/ISS</b>						
1"	-	664 ±2	-	-	-	-
1½"	-	-	854 ±2	-	-	-
2"	-	-	-	1076 ±2	-	-
3"	-	-	-	-	1354 ±2	-
<b>Male thread RJT</b>						
1"	-	676 ±2	-	-	-	-
1½"	-	-	866 ±2	-	-	-
2"	-	-	-	1088 ±2	-	-
3"	-	-	-	-	1366 ±2	-

	Dimension B [inches]					
	T/S 10	T/S 15	T/S 25	T/S 40	T/S 50	T/S 80
<b>Male thread DIN 11851</b>						
DN10	23.5 ±0.08	-	-	-	-	-
DN15	-	25 ±0.08	-	-	-	-
DN25	-	-	31.6 ±0.08	-	-	-
DN40	-	-	-	41 ±0.08	-	-
DN50	-	-	-	-	48 ±0.08	-
DN80	-	-	-	-	-	65.3 ±0.08
<b>Male thread SMS</b>						
1"	-	26.2 ±0.08	-	-	-	-
1½"	-	-	33.5 ±0.08	-	-	-
2"	-	-	-	42.3 ±0.08	-	-
3"	-	-	-	-	53.5 ±0.08	-
<b>Male thread IDF/ISS</b>						
1"	-	26.1 ±0.08	-	-	-	-
1½"	-	-	33.6 ±0.08	-	-	-
2"	-	-	-	42.4 ±0.08	-	-
3"	-	-	-	-	53.3 ±0.08	-
<b>Male thread RJT</b>						
1"	-	26.6 ±0.08	-	-	-	-
1½"	-	-	34.1 ±0.08	-	-	-
2"	-	-	-	42.8 ±0.08	-	-
3"	-	-	-	-	53.8 ±0.08	-

2.4.3 Heating jacket version

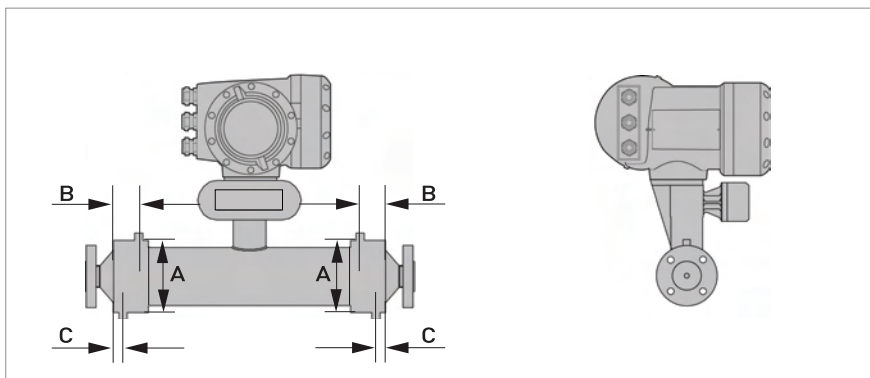

	Dimensions [mm]					
	10	15	25	40	50	80
Heating connection size	12mm (ERMETO)			25mm (ERMETO)		
A	115 ±1		142 ±1	206 ±1	254 ±1	305 ±1
<b>Titanium</b>						
B	36 ±1	51 ±1	100 ±1	90 ±1	175 ±1	385 ±1
C	20			26 ±1		
<b>Stainless Steel &amp; Hastelloy®</b>						
B	-	51 ±1	55 ±1	90 ±1	100 ±2	200 ±2
C	-	20		26 ±1		
<b>Tantalum</b>						
B	-	51 ±1	55 ±1	90 ±1	100 ±1	-
C	-	20		26 ±1		-

	Dimensions [inches]					
	10	15	25	40	50	80
Heating connection size	½" (NPTF)			1" (NPTF)		
A	4.5 ±0.04		5.6 ±0.04	8.1 ±0.04	10 ±0.04	12 ±0.04
<b>Titanium</b>						
B	1.4 ±0.04	2 ±0.04	3.9 ±0.04	3.5 ±0.04	6.9 ±0.04	15.2 ±0.04
C	0.8			1.0 ±0.04		
<b>Stainless Steel &amp; Hastelloy®</b>						
B	-	2 ±0.04	2.2 ±0.04	3.5 ±0.04	3.9 ±0.08	7.9 ±0.08
C	-	0.8		1.0 ±0.04		
<b>Tantalum</b>						
B	-	2 ±0.04	2.2 ±0.04	3.5 ±0.04	3.9 ±0.04	-
C	-	0.8		1.0 ±0.04		-

## 2.4.4 Purge port option

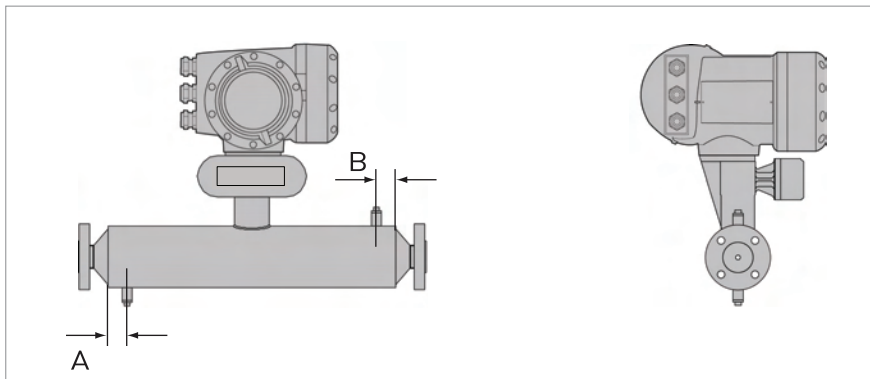

Dimensions [mm]							
	06	10	15	25	40	50	80
<b>Titanium &amp; Stainless Steel</b>							
A	65	30			65		
B	30				65		
<b>Hastelloy®</b>							
A	-	30			65		
B	-	30			65		
<b>Tantalum</b>							
A	-	-	30		65		-
B	-	-	30		65		-

Dimensions [inches]							
	06	10	15	25	40	50	80
<b>Titanium &amp; Stainless Steel</b>							
A	2.6	1.2			2.6		
B	1.2				2.6		
<b>Hastelloy®</b>							
A	-	1.2			2.6		
B	-	1.2			2.6		
<b>Tantalum</b>							
A	-	-	1.2		2.6		-
B	-	-	1.2		2.6		-

## 3.1 Intended use

This mass flowmeter is designed for the direct measurement of mass flow rate, product density and product temperature. Indirectly, it also enables the measurement of parameters like total mass, concentration of dissolved substances and the volume flow. For use in hazardous areas, special codes and regulations are also applicable and these are specified in a separate documentation.

## 3.2 Mounting restrictions

### 3.2.1 General installation principles

**There are no special installation requirements but you should note the following points:**

- Support the weight of the meter.
- The meter can be supported on the sensor body.
- On larger meter sizes and hygienic connections, it is strongly recommended that the meter is not supported solely by the process pipework.
- No straight runs are required.
- The use of reducers and other fittings at flanges, including flexible hoses, is allowed but you should take care to avoid cavitation.
- Avoid extreme pipe size reductions.
- Meters are not affected by crosstalk and can be mounted in series or in parallel.
- Avoid mounting the meter at the highest point in the pipeline where air / gas can collect.

### Mounting positions

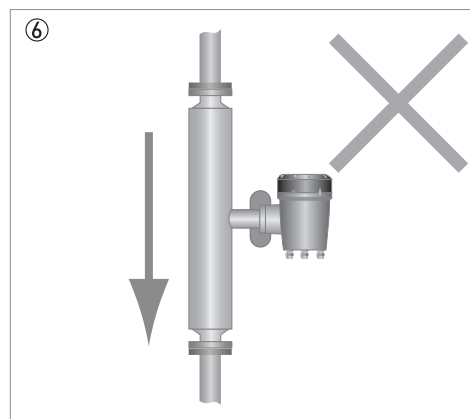
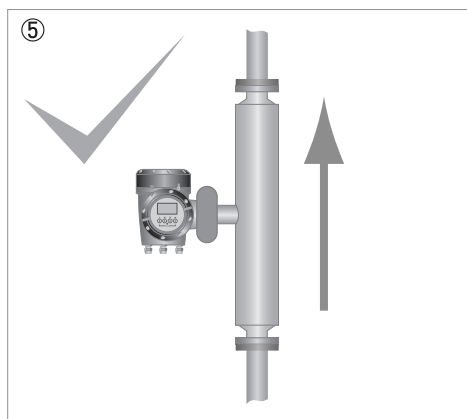
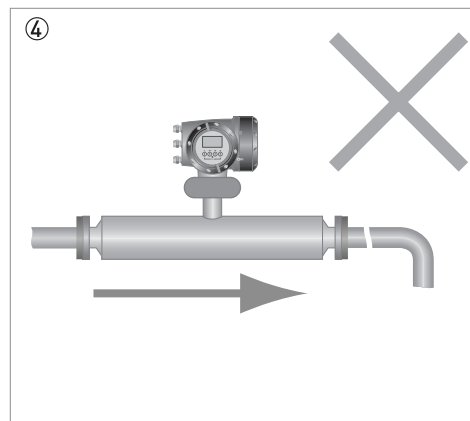
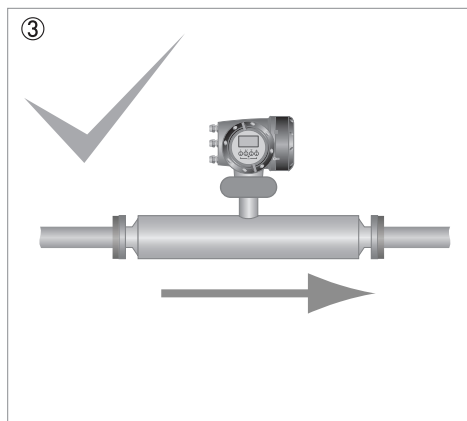
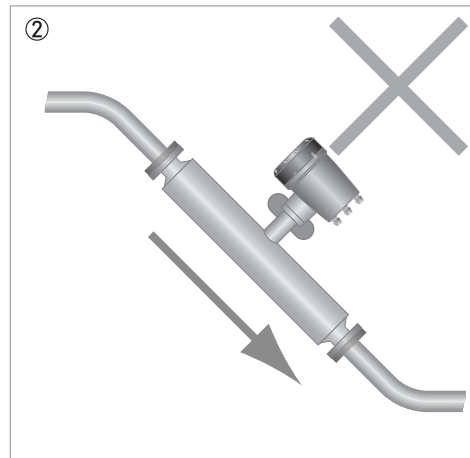
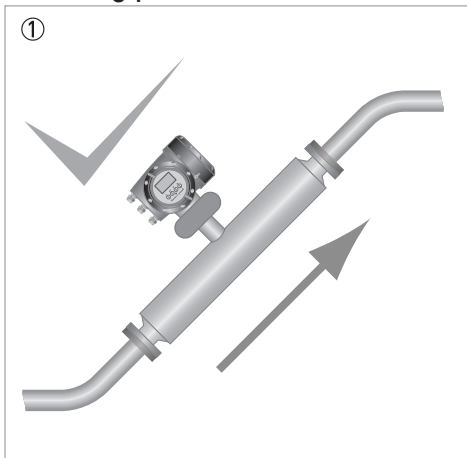

- ① The meter can be mounted at an angle but it is recommended that the flow is uphill.
- ② Avoid mounting the meter with the flow running downhill because it can cause siphoning. If the meter has to be mounted with the flow running downhill, install an orifice plate or control valve downstream of the meter to maintain backpressure.
- ③ Horizontal mounting with flow running left to right.
- ④ Avoid mounting meter with long vertical runs after the meter as it can cause cavitation. Where the installation includes a vertical run after the meter, install an orifice plate or control valve downstream to maintain backpressure.
- ⑤ The meter can be mounted vertically but it is recommended that the flow is uphill.
- ⑥ Avoid mounting the meter vertically with the flow running downhill. This can cause siphoning. If the meter has to be installed this way, install an orifice plate or control valve downstream to maintain backpressure.

**Zero calibration**

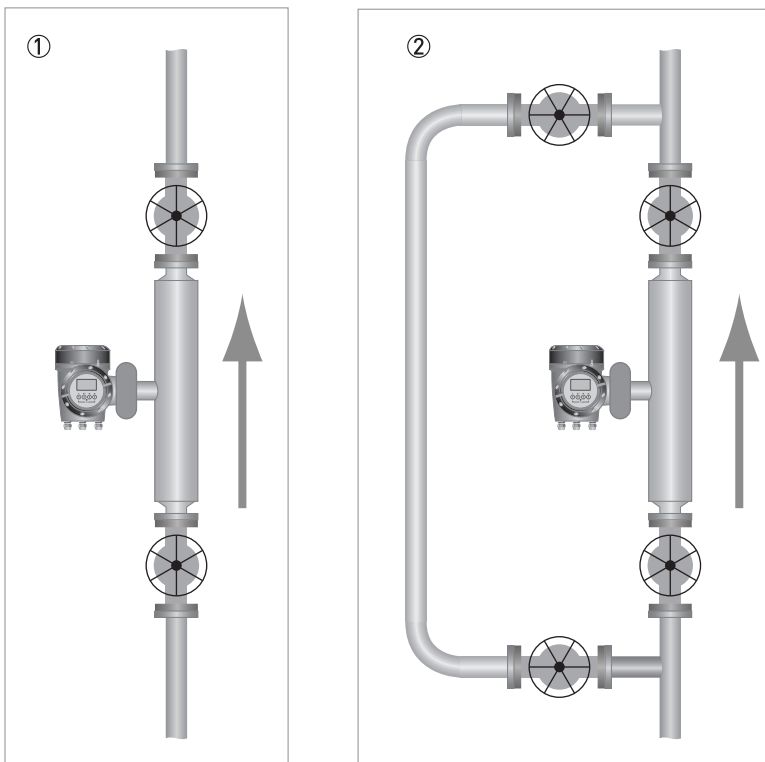

- ① Where the meter has been installed vertically, install shut-off valves either side of the meter to assist with zero calibration.
- ② If the process flow cannot be stopped, install a bypass section for zero calibration.

**3.2.2 Sunshades**

The meter **MUST** be protected from strong sunlight.

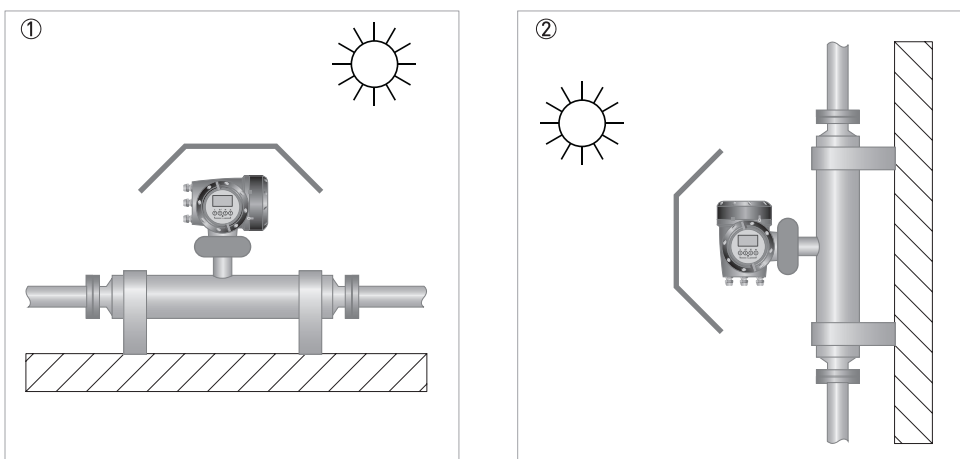

- ① Horizontal installation
- ② Vertical installation





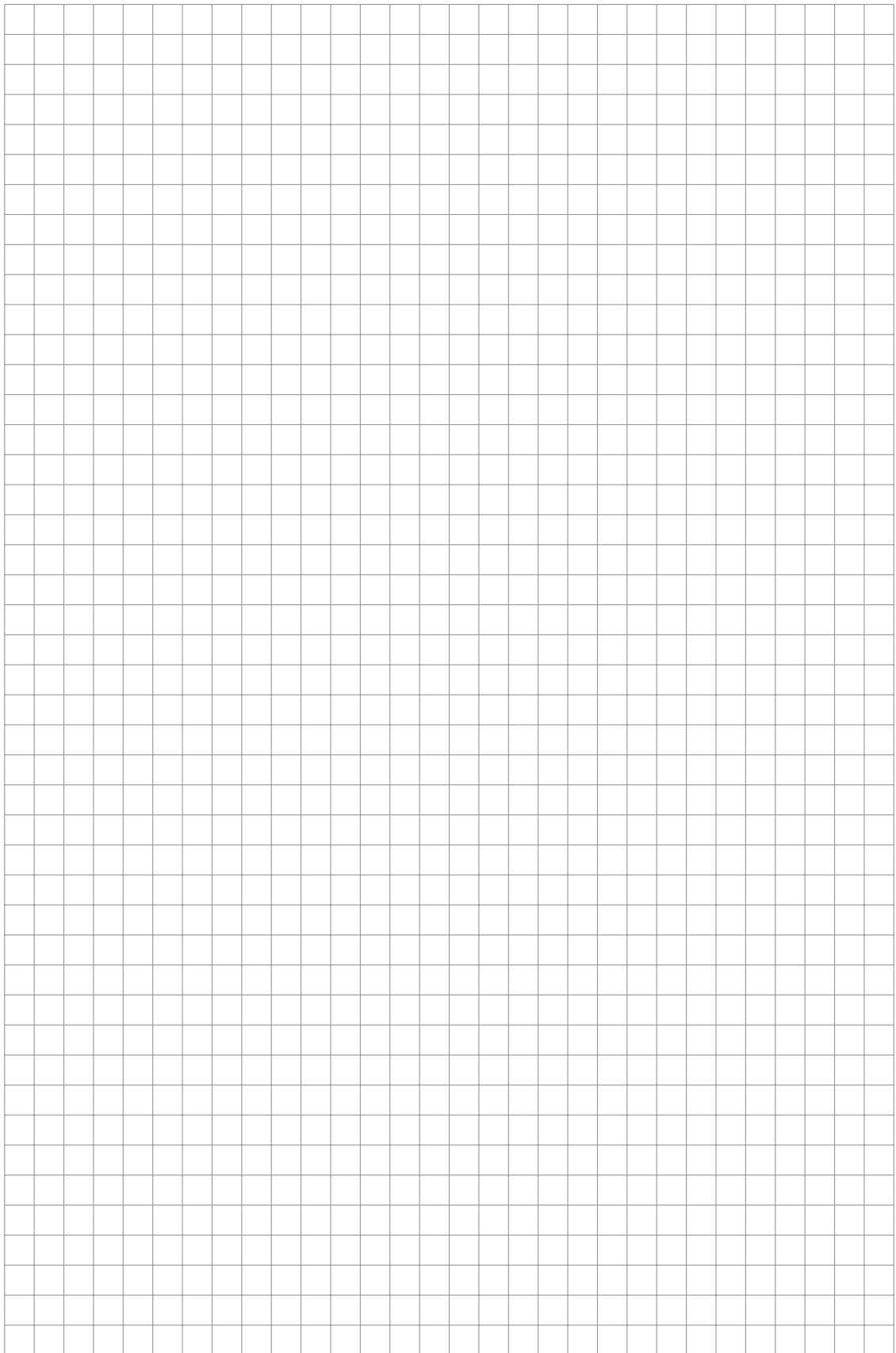



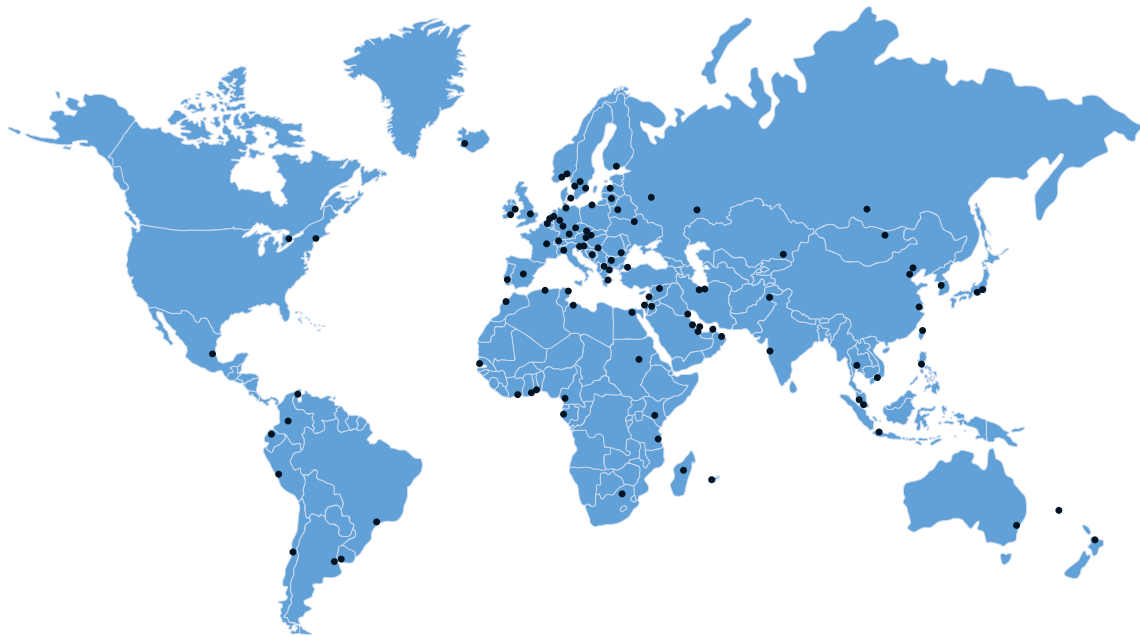

### KROHNE product overview

- Electromagnetic flowmeters
- Variable area flowmeters
- Ultrasonic flowmeters
- Mass flowmeters
- Vortex flowmeters
- Flow controllers
- Level meters
- Temperature meters
- Pressure meters
- Analysis products
- Measuring systems for the oil and gas industry
- Measuring systems for sea-going tankers

Head Office KROHNE Messtechnik GmbH & Co. KG  
Ludwig-Krohne-Str. 5  
D-47058 Duisburg  
Tel.: +49 (0)203 301 0  
Fax: +49 (0)203 301 10389  
info@krohne.de

The current list of all KROHNE contacts and addresses can be found at:  
[www.krohne.com](http://www.krohne.com)

**KROHNE**