

Installation and Operating Instructions

BM 500



Variable area flowmeters

Vortex flowmeters

Flow controllers

Electromagnetic flowmeters

Ultrasonic flowmeters

Mass flowmeters

Level measuring instruments

Communications technology

Engineering systems & solutions

Switches, counters, displays and recorders

Heat metering

Pressure and temperature

Contents

Safety information	3
Items includes with supply	3
Product liability and warranty	3
CE / EMC / Standards/ Approvals	3
1 Installation	4
1.1 Mechanical installation	4
1.2 Process connection	4
2 Electrical connection	5
2.1 Connection diagram	5
2.2 Start-up	5
2.3 Operator control	6
3 Fault diagnosis and corrective action	6
4 Technical data	7
4.1 Table of technical data	7
4.2 Dimensions	7
5 Type code	8
5.1 Ordering code	8
5.2 Spare parts	8
5.3 Accessoires	8
6 Product description	9
6.1 Applications	9
6.2 Functional principle	9
6.3 Construction	10
6.4 Features	10
If you need to return a device for testing or repair to KROHNE	11

Safety information

Please read this manual carefully, and also take note of country-specific installation standards (e.g. the VDE regulations in Germany) as well as prevailing safety regulations and accidents prevention rules. For safety and warranty reasons, any internal work on the instruments, apart from that involved in normal installation and electrical connection, must be carried out only by qualified KROHNE personnel.

Items included with supply

- Measuring instrument
- Hygienic adapter
- Installation and operating instructions

Product liability and warranty

Responsibility for suitability and intended use of these instruments rests solely with the operator. Improper installation and operation of the instruments may lead to loss warranty.

In addition, the "General conditions of sale" forming the basis of the purchase contract are applicable.

If instruments need to be returned to KROHNE, please note the information given on the last-but-one page of these instructions.

KROHNE regrets that it cannot repair or check your instruments unless accompanied by a fully completed Service and Repair sheet.

CE / EMC / Standards/ Approvals

The product bears the CE marking on account of compliance with and application of the following standards:

EMCG (89/336/EEC)

EN 50081-1	EN 55022 Class B
EN 61000-6-2	EN 61000-4-2 ESD 4/8 kV
	EN 61000-4-3 HF radiated 10 V/m
	EN 61000-4-4 Burst 4 kV
	EN 61000-4-5 Surge 1 kV sym., 2 kV unsym.
	EN 61000-4-6 HF cable 10 V

1 Installation

1.1 Mechanical installation

- Be sure that the sensor tube has the correct depth of immersion when placing your order. The sensor **cannot** be shortened subsequently!
- Use only the recommended sleeves or adapters. If other systems are used, no guarantee can be given for proper functioning or leak-tightness.
- The connection thread must have electrical contact with the metal vessel. If this is not possible, use a separate grounding cable to meet this condition.
- Do not use Teflon or paper gaskets.
- The tightening torque for the sleeve should be between 20 and 30 Nm.
- If the vessel is electrically non-conductive (e.g. plastic tank), the frame potential can be established via an additional ground electrode, which is electrically connected to the connection thread. Best results are obtained with a rod electrode parallel to the sensor rod.
- Make absolutely sure that the sensor rod cannot come into contact with the wall of the vessel. Also take into consideration the possibility of rod deflection caused by moving product.
- The distance to the vessel wall is not critical. For distances of less than 100 mm (e.g. when installed in vertical pipe runs) the sensor rod should be located parallel to the wall, otherwise conditions of non-linearity can occur.
- The sensor measures linearly over the full rod length. Only approx. 8 mm of the lower end of the rod count as the dead zone.

1.2 Process connection

The hygienic 1" process sleeve is easy to weld into tanks or pipes.

The marking points to the centre of the future position of the cable gland or M12 connector. This form of assembly allows installation in conformity with hygiene standards (EHEDG, FDA). Various adapter sleeves (see Accessories) allow hygienic fitting to other process connections.

The sensor can be installed in any desired position, also from below or at an incline. The electronic equipment adjusts automatically to the installation situation.



2 Electrical connection

2.1 Connection diagram

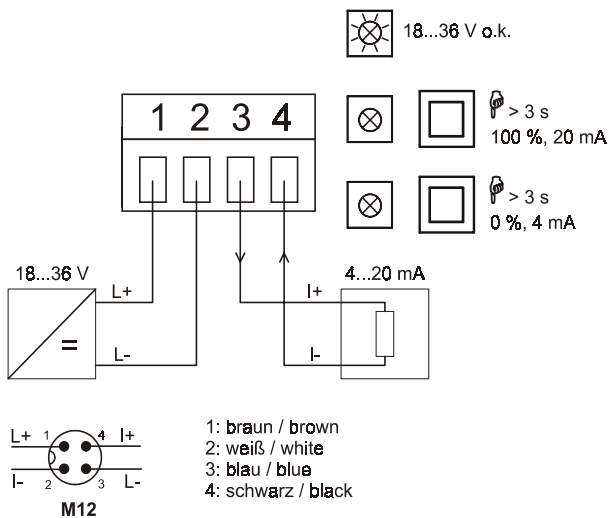

Terminals 1(+) and 2(-) are used for supplying a DC voltage of 18...36 V. Terminal 2 is connected to the housing via a protective diode.

The maximum power consumption is 200 mA. This value should be taken into account in connection with the recommended use of a fuse.

An active, galvanically isolated 4...20 mA current output is provided at terminals 3 and 4. Please pay regard to applicable wiring regulations.

2.2 Start-up

- Check that the sensor rod is not in contact with the vessel wall.
- Check the leak-tightness at the sleeve.
- Make sure that the cable glands are tight or, as the case may be, the M12 plugs are properly screwed down.

2.3 Operator control

- The green LED indicates that supply voltage is present (operation indicator).
- The 2 red LEDs show different flashing rates (LED monitor), according to the control of the current output.
- The sensor is factory-calibrated for installation from above. This corresponds to 4 mA at the lower rod end and 20 mA at the upper end (PEEK insulating part). When installed from below, a value of slightly more than 4 mA is obtained, due to the system, when the PEEK part is just covered.
- The 4 mA and 20 mA values can be adjusted at any time by actuating the two recessed keys (e.g. using a screwdriver). By pressing one of the two keys for more than 3 seconds, the value adjusts to 4 mA or 20 mA for the current product level. The relevant LED at the LED monitor then shows a steady light. Should the product level for 20 mA be lower than at 4 mA, a negative characteristic is automatically present.
- Adjustment is only recommended if this is necessary due to the system, e.g. for matching to a smaller range.
- The factory calibration can be reinstated at any time by pressing both keys simultaneously (>3s) (Factory Reset).
- The “dry” signalling threshold is set simultaneously with the low level calibration. When the conductivity measured here is undershot, the sensor signals the “dry” condition with a current output value of 2.4 mA. Given different products with widely differing conductivity, the 4 mA adjustment should be carried out using the least conductive liquid.

3 Fault diagnosis and corrective action

In the event of a fault or malfunction, please go through the various possible faults listed in the table.

Please do not attempt to take the device apart.

There are no parts requiring maintenance.

Fault	Cause	Action/elimination
LED status display not “on”	Supply voltage < 18 V	Measure voltage at pin 1, 2.
	Supply voltage has false polarity	Reverse terminals 1, 2
Current output < 4 mA	Sensor “dry”	o.k.
	Conductivity too low	4 mA adjustment
	No connection to frame	Check connection to frame / thread
Measured value incorrect	Adjustment faulty	Adjustment or Factory Reset
	Poor connection to frame	Check connection to frame / thread

If the fault cannot be located, please contact our Technical Services.

4 Technical data

4.1 Table of technical data

Connection head	Stainless steel V2A 1.4305; 89 mm dia.
Electrical connection	Cable gland M16; M12 connector
Process connection	Threaded socket G1" h; V4A 1.4571
Sensor rod	Stainless steel V4A 1.4571; 10 mm dia.
Sensor length	200 ... 1500 mm; customer specific sensor length
Type of protection	IP 67
Insulating part	PEEK
Temperature range	-20...+140 °C
Operating pressure	max. 10 bar
Mounting position	Automatic identification of top/bottom
Output	4...20 mA; load impedance 500 ohms max.
"Empty" signal	Output 2.4 mA
Repeatability	± 0.5%
Power supply	18...36 V DC; 200 mA max.

4.2 Dimensions

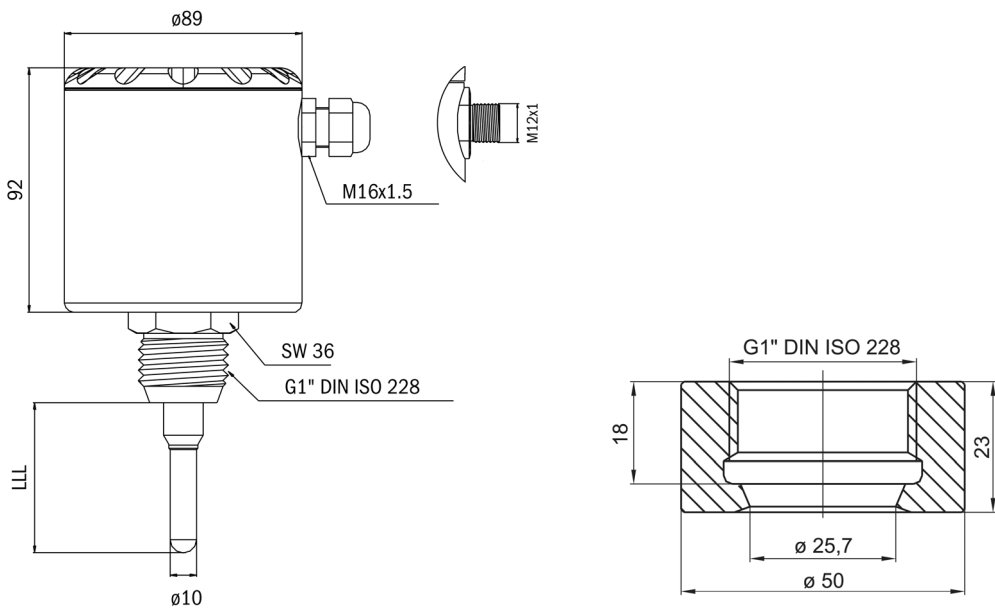

Dimensions in mm

5 Type code

5.1 Ordering code

VGP 3	0	1	BM 500			
			Sensor length			
			1	200 mm	A	1000 mm
			2	300 mm	B	1100 mm
			3	400 mm	C	1200 mm
			4	500mm	D	1300 mm
			5	600 mm	E	1400 mm
			6	700 mm	F	1500 mm
			7	800 mm	G	Customer specific sensor length
			8	900 mm	H	> 1500 mm
			Electrical Connection			
			1	Screwed cable gland M 16		
			2	Plug M 12		
			Accessories			
			0	Without		
			1	sealed electronic		
			Certificates			
			0	Without		
VGP3	0	1				Order designation

5.2 Spare parts

Should a replaceable part of the sensor be lost or damaged, replacements can be ordered on the basis of the part number.

Designation	Type
Housing cover	KMD.006.090.000
Cable gland M16	KVV.M16.010.008
Connector insert M12	KVV.100.004.000
Connector part 4-pin	KVK.046.210.018

5.3 Accessoires

Designation	Type
Weld-in sleeve	HWN 500
Varivent flange, version N	HVF 550
Sanitary pipe assembly kit DN 50	HMT 550
Tri-Clamp flange DN 32, DN 40, 2"	HTC 550

6 Product description

6.1 Applications

The level sensor is designed to measure continuously the level of liquids and pasty and sticky products.

The sensor is particularly suitable for measuring low levels in the 50 mm to 1000 mm range.

Thanks to the principle involved, this potentiometric measuring system is independent of sticky deposits and varying product properties. All it needs is a minimum conductivity of 1 $\mu\text{S}/\text{cm}$.

6.2 Functional principle

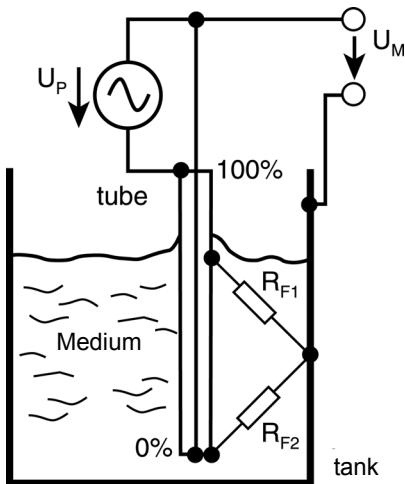

The measuring principle is comparable to that of a slider potentiometer, with in this case the liquid representing the slider pick-off.

An alternating current is applied to a stainless steel tube to cause a drop in voltage via the electrical resistance of the tube (cf. slider path). The conductive wall of the vessel forwards the tapped voltage conducted through the liquid to a high-resistance amplifier. Based on the supply voltage, this yields the ratio between the depth of immersion and the total length of the tube.

Together with the high-resistance pick-off, this ratio explains why the measuring system is independent of the conductivity of the product. Sticky deposits merely form a parallel connection with the anyway very low-resistance tube. What is measured, therefore, is only the actual product between tube and vessel wall.

6.3 Construction

The process weld-in sleeve of stainless steel ensures installation in keeping with standards of hygiene.

The electronic evaluation unit is totally integrated in the stainless steel connection head. It supplies a galvanically isolated 4...20 mA signal that is proportional to the level.

6.4 Features

- Sensor made entirely of stainless steel
- Compact design; integrated electronic unit
- Materials in conformity with food standards
- Thermally stable up to 140°C
- For viscous, pasty and heavily sticky products (e.g. ketchup, honey, toothpaste)
- Defined "empty" signalling function
- Level monitor 0...100% by way of flashing rate from 2 LEDs
- Keys for calibration of 4-mA point and 20-mA point
- Direct connection to an SPC or PLC
- Hygienic adapter sleeves for other process connections

If you need to return a device for testing or repair to KROHNE

Your instrument has been carefully manufactured and tested. If installed and operated in accordance with these operating instructions, your instrument will rarely present any problems. Should you nevertheless need to return an instrument for checkout or repair, please pay strict attention to the following points:

Due to statutory regulations concerning protection of the environment and safeguarding the health and safety of our personnel, KROHNE may only handle, test and repair returned instruments that have been in contact with liquids if it is possible to do so without risk to personnel and environment.

This means that KROHNE can only service your instrument if it is accompanied by a certificate in line with the following model confirming that the instrument is safe to handle.

If the instrument has been operated with toxic, caustic, flammable or water-endangering liquids, you are kindly requested

- to check and ensure, if necessary by rinsing or neutralizing, that all cavities in the instrument are free from such dangerous substances.
(Directions on how you can find out whether the primary head has to be opened and then flushed out or neutralized are obtainable from KROHNE on request.)
- to enclose a certificate with the instrument confirming that the instrument is safe to handle and stating the liquid used.

KROHNE regret that they cannot service your instrument unless it is accompanied by such a certificate.

SPECIMEN certificate

Company: Address:

Department: Name:

Tel. No.:

The enclosed instrument

Type:

KROHNE Order No. or Series No

has been operated with the following liquid:

Because this liquid is
water-endangering * / toxic * / caustic * / flammable *
we have

- checked that all cavities in the instrument are free from such substances *
- flushed out and neutralized all cavities in the flowmeter *

(* delete if not applicable)

We confirm that there is **no** risk to man or environment through any residual liquid contained in the instrument.

Date: Signature:

Company stamp: