

KROHNE

© KROHNE 12/2003

7.02277.21.00

GR

Installation and Operating Instructions

PTD 500

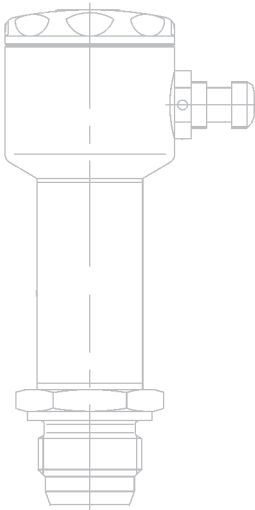

Variable area flowmeters

Vortex flowmeters

Flow controllers

Electromagnetic flowmeters

Ultrasonic flowmeters

Mass flowmeters

Level measuring instruments

Communications technology

Engineering systems & solutions

Switches, counters, displays and recorders

Heat metering

Pressure and temperature

Content

Safety information	3
Items includes with supply	3
Produkthaftung und Garantie	3
CE / EMC / Standards/ Approvals	3
1 Installation	4
1.1 Mechanical installation.....	4
1.2 Process connection.....	4
1.3 Electrical connection.....	4
1.3.1 Connection diagrams.....	5
1.3.2 Start-up.....	5
1.3.3 Operator control.....	5
2 Technical data	6
2.1 Technical data.....	6
2.2 Dimensions	7
3 Ordering code	8
3.1 Ordering code	8
3.2 Spare parts	8
3.3 Accessories	8
4 Product description	9
4.1 Applications	9
4.2 Functional principle	9
4.3 Construction.....	9
4.4 Features.....	9
If you need to return a device for testing or repair to KROHNE	11

Safety information

Please read this manual carefully, and also take note of country-specific installation standards (e.g. the VDE regulations in Germany) as well as prevailing safety regulations and accidents prevention rules. For safety and warranty reasons, any internal work on the instruments, apart from that involved in normal installation and electrical connection, must be carried out only by qualified KROHNE personnel.

Items included with supply

- Measuring instrument
- Hygienic adapter
- Installation and operating instructions

Produkthaftung und Garantie

Responsibility for suitability and intended use of these instruments rests solely with the operator. Improper installation and operation of the instruments may lead to loss warranty.

In addition, the “General conditions of sale” forming the basis of the purchase contract are applicable.

If instruments need to be returned to KROHNE, please note the information given on the last-but-one page of these instructions.

KROHNE regrets that it cannot repair or check your instruments unless accompanied by a fully completed Service and Repair sheet.

CE / EMC / Standards/ Approvals

The product bears the CE marking on account of compliance with and application of the following standards:

EMCG (89/336/EEC)

EN 50081-1, 50081-2	EN 61326
EN 50121-4	

1 Installation

1.1 Mechanical installation

- Use only the recommended sleeves or adapters. If other systems are used, no guarantee can be given for proper functioning or leak tightness.
- Before installing and dismantling the sensor, make sure that the system is non-pressurised!
- Do not use Teflon or paper gaskets.
- Insert the measuring head with care and straight into the sleeve. Screw the sensor in by hand. Then tighten down using an open-end wrench applied to the hexagon (jaw size 41) with a torque between 20 and 30 Nm.
- On no account may a tightening torque be applied anywhere else other than at the hexagon!
- Following assembly, the position marking of the sleeve points to the outgoing cable and the filter cover for the air vent. When welding in the sleeve, please bear this in mind for suitable positioning.

1.2 Process connection

The hygienic G1" process sleeves are easy to weld into tanks or pipes. The marking points to the centre of the future position of the cable glands or M12 connector. This form of assembly allows installation in conformity with standards of hygiene (to EHEDG, 3A and FDA).

Various hygienic adapter sleeves (see Accessories) are available for fitting to other process connections. The device can be installed in any desired position.



1.3 Electrical connection

- Installation of the device in the plant may only be carried out by an electrician. Observe the national and international regulations for the installation of electrical systems and equipment.
- For voltage supplies, use a suitable power supply unit (EN50178, SELV, PELV) with a voltage of between 16 V and 30 V.
- Disconnect the plant from supply before connecting up the devices.
- Do not loosen or detach connections when energised.
- To avoid adverse effects due to interference voltages, a shielded cable is recommended if there is any greater distance between sensor and display.
- The sensor operates as a 2-wire device (current sink). Normally, connection of cables L+ (1) and I - (2) will suffice, see connection diagram 1.

1.3.1 Connection diagrams

PTD 500

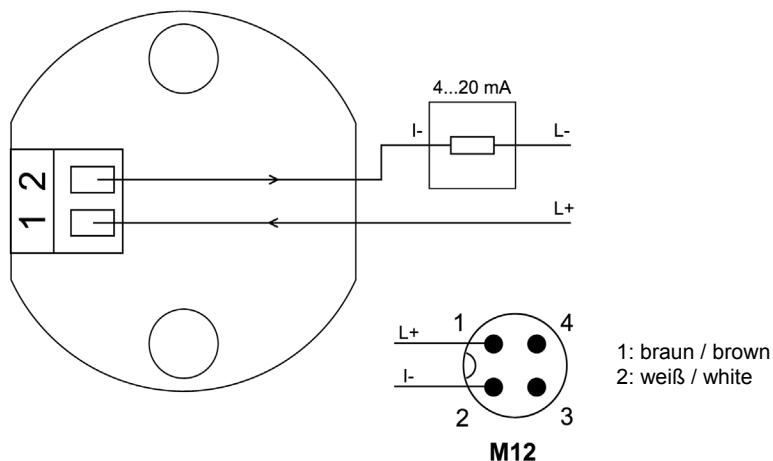

1.3.2 Start-up

- Check for leak-tightness at the sleeve.
- Make sure that the cable glands are tight and, as the case may be, the M12 connectors are properly tightened down.
- Check that the device is functioning properly (current output).
- Make sure that the housing lid is screwed down tight.

1.3.3 Operator control

- The device itself has no an auto zero function by pressing the button located behind the electrical plug

2 Technical data

2.1 Technical data

Housing materials	SS 1.4301,1.4305/ SS 304,PBT(M12), PA (plug)
Electrical connection	Cable gland or M12 connector 4-pin (plug)
Type (class) of protection	IP 67, III
Insulation resistance	> 1 GOhm (500 V DC)
Shock resistance	EN 60068-2-6
Vibration resistance	EN 60068-2-6
Ambient temperature	-25...+80 °C
Voltage supply	10...30 V DC
Analogue output	4...20 mA
Max. load impedance	$R_L < 50 \times U_b - 450\Omega$
Rise time 1)	25 ms
Accuracy in % 2)	< ± 0.4 %
- Linearity	< ± 0.1 %
- Hysteresis	< ± 0.05 %
- Repeatability	< ± 0.05 %
- Long-time stability	< ± 0.2 % FS / year
Temperature coefficients	Span < $\pm 0,1$ % / 10 K
Process temperature	-30...+125 °C (not compensated), -10..+80°C (comp.)
CIP/ SIP	+140 °C, (max. 60 minutes)
Wetted materials	1.4435/1.4404

1) damping dAA = 0

2) all details based on a turn-down ratio of 1:1 in % of span

2.2 Dimensions

PTD 500

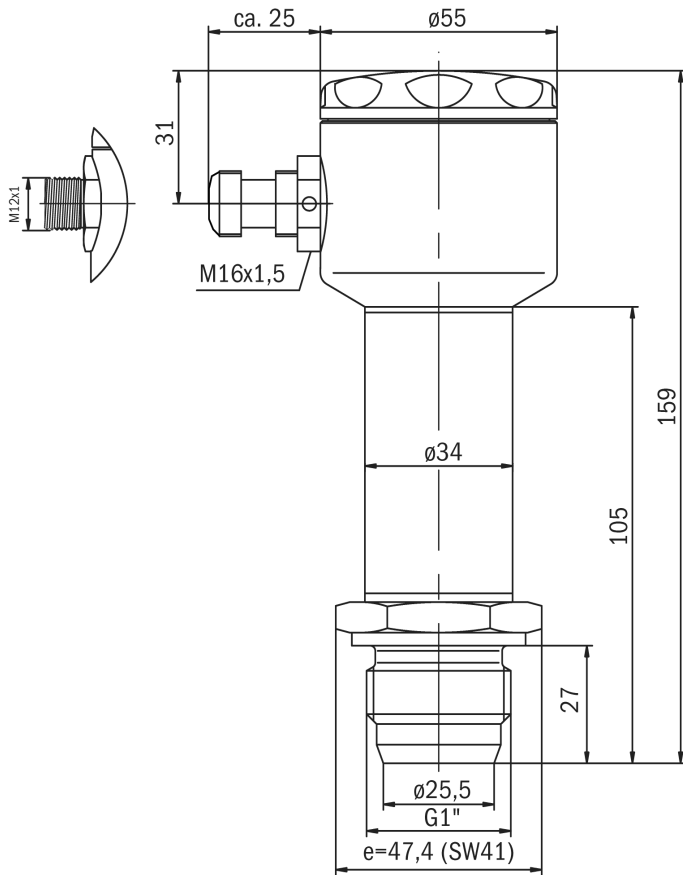

Dimensions in mm

3 Ordering code

3.1 Ordering code

Identification Key Pressure Sensor

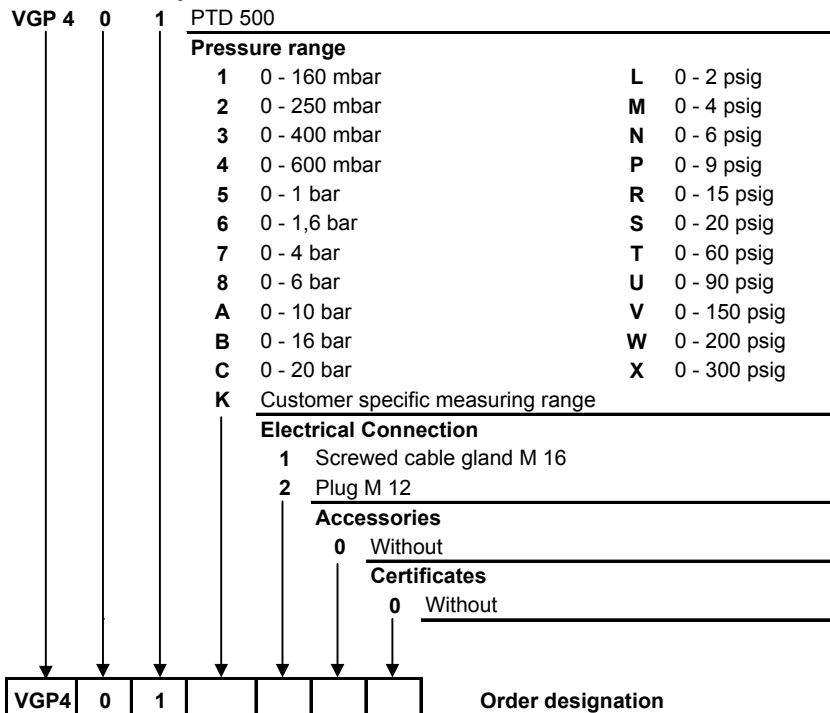

3.2 Spare parts

Should a replaceable part of the pressure sensor be lost or damaged, a replacement can be ordered on the basis of the appropriate parts number.

Designation	Type
Housing lid	KMD.008.055.100
Cable gland M16	KVV.M16.010.008
Plug insert M12	KVV.100.004.000
Plug-in part, 4-pin	KVK.046.210.018

3.3 Accessories

Designation	Typ
Varivent flange version N	HVF 550
Sanitary pipe assembly kit DN 50	HMM 550
Tri-Clamp flange DN 32, DN 40, 2"	HTC 550
Programming and display device	PPM 100

Other process connections available on request.

4 Product description

4.1 Applications

The pressure sensor with flush-front stainless steel diaphragm and piezoresistive measuring principle is suitable for pressure and hydrostatic pressure level measurement demanding high standards in terms of hygiene and accuracy. The sensor is distinguished by an extremely good long-time stability, a very small temperature drift and good overload withstand capability.

4.2 Functional principle

The piezo-resistive silicon sensor is anodic bonded on a very stable glass base, which is attached to a stainless steel construction. This assembly guarantees an excellent thermal isolation. The sensor is located from the process by a stainless steel diaphragm (1.4404/316 L) and a filling liquid.

4.3 Construction

The weldable process sleeve, made of stainless steel, ensures installation in keeping with hygiene requirements. The electronic evaluator is fully integrated into the stainless steel housing. The connection head allows convenient and reliable electrical connection. The device supplies a 4...20-mA signal in 2-wire connection technology (current sink).

4.4 Features

- Compact design, of stainless steel
- Integrated electronic unit with 4...20-mA current sink
- flush-front stainless steel diaphragm and piezoresistive measuring principle
- High overload withstand capability
- Optimum corrosion and abrasion resistance
- With CIP and SIP capability
- Defined position of the cable gland
- Hygienic adapter sleeves for other process connections

Notes

If you need to return a device for testing or repair to KROHNE

Your instrument has been carefully manufactured and tested. If installed and operated in accordance with these operating instructions, your instrument will rarely present any problems. Should you nevertheless need to return an instrument for checkout or repair, please pay strict attention to the following points:

Due to statutory regulations concerning protection of the environment and safeguarding the health and safety of our personnel, KROHNE may only handle, test and repair returned instruments that have been in contact with liquids if it is possible to do so without risk to personnel and environment.

This means that KROHNE can only service your instrument if it is accompanied by a certificate in line with the following model confirming that the instrument is safe to handle.

If the instrument has been operated with toxic, caustic, flammable or water-endangering liquids, you are kindly requested

- to check and ensure, if necessary by rinsing or neutralizing, that all cavities in the instrument are free from such dangerous substances.
(Directions on how you can find out whether the primary head has to be opened and then flushed out or neutralized are obtainable from KROHNE on request.)
- to enclose a certificate with the instrument confirming that the instrument is safe to handle and stating the liquid used.

KROHNE regret that they cannot service your instrument unless it is accompanied by such a certificate.

SPECIMEN certificate

Company: Address:

Department: Name:

Tel. No.:

The enclosed instrument

Type:

KROHNE Order No. or Series No

has been operated with the following liquid:

Because this liquid is
water-endangering * / toxic * / caustic * / flammable *
we have

- checked that all cavities in the instrument are free from such substances *
- flushed out and neutralized all cavities in the flowmeter *

(* delete if not applicable)

We confirm that there is **no** risk to man or environment through any residual liquid contained in the instrument.

Date: Signature:

Company stamp: