

**C-Frame**

Double Crank Power Presses

# G2

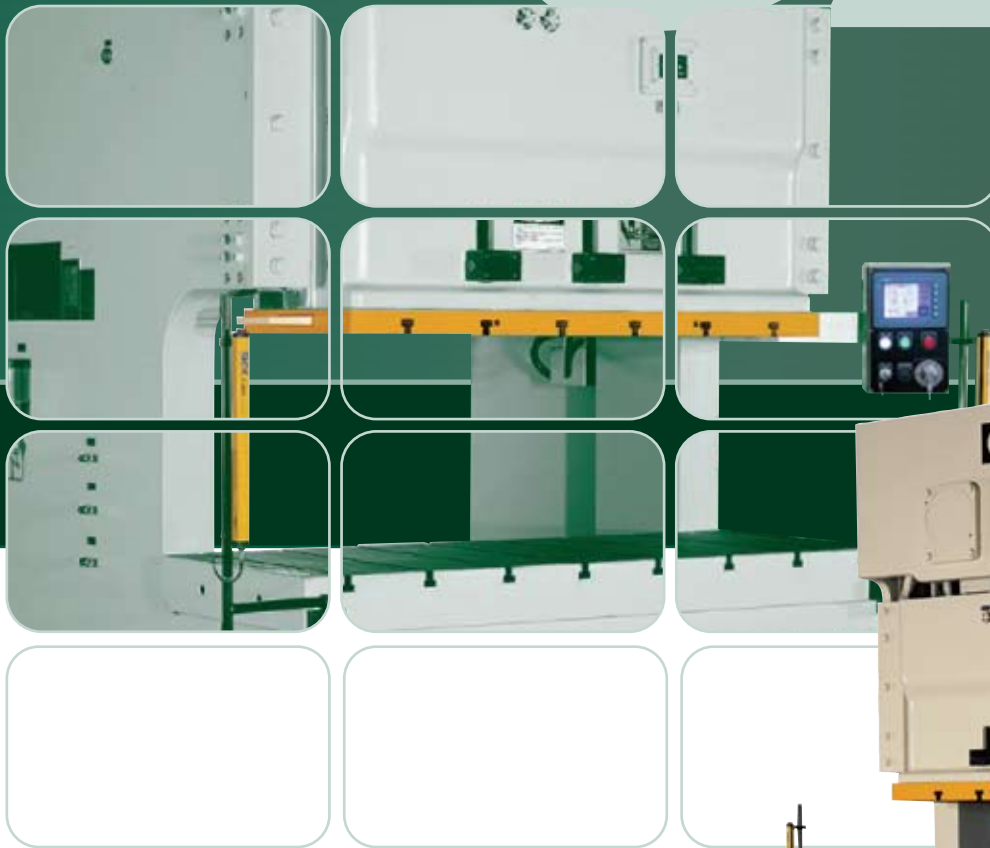

# G2

## C-Frame Double Crank Power Presses

The Stamtec G2 series two point gap frame press (aka OBG, OBS, OBI, or c-frame) was designed for stamping relatively long, narrow parts at high single stroking rates or in continuous mode, using either blanks or coil stock; or running progressive dies that need the longer bed area to accommodate long dies with multiple stations. The slide is guided by six (6)-point full-length box type gibs, providing excellent control of slide alignment and accuracy throughout the entire stroke.

The G2 series provides a large die area at a very economical price, especially in applications where it can be used effectively instead of a straight side press.



### STANDARD FEATURES

- Wet type clutch and brake
- Hydraulic overload system
- Super rigid, low deflection steel frame
- Large window
- Cast slide, with removable, t-slotted slide plate
- Motorized slide adjustment
- Wide, box-type centered gibs
- Air counterbalance system
- T-slotted bolster
- Flywheel brake
- Automatic lubrication system
- Digital die height indicator
- Overrun detector (brake monitor)
- Motorized grease pump
- Dual air safety valve
- Floor standing electric control cabinet
- Press control with:
  - » Six (6) programmable limit switches
  - » Four (4) programmable die motor inputs
  - » 6-digit part & batch counters
  - » LCD display screen for status and fault messages
  - » LED display for crank angle and spm
  - » Interlocked die safety block
- HMI operation panel
  - » Electronic crank angle LED display
  - » Electronic S.P.M. LED display
  - » LCD type press status monitor
- Operation mode selection
  - » Off / inching / safety one stroke / continuous
- Total counter, 6 digits
- Preset counter, 6 digits
- Maintenance counter, 4 digits
- Life counter, 10 digits
- Electronic rotary cam (6 spare channels)
- Air ejector, 3/8", one channel
- Air source receptacle, 3/8", two channel
- Misfeed detection circuit
- Power receptacle (available only for single phase, 110V power source wiring by user)
- Flywheel safety guard
- Eddy current drive VS motor
- Main motor reversing circuit
- Portable 2-hand pushbutton t-stand
- Inverter & main motor reversing circuit

### OPTIONAL FEATURES

- Link motion drive technology
- Press controls from industry leaders such as Wintriss, Link, Helm (Allen-Bradley), Toledo (Allen-Bradley) Siemens, Mitsubishi, etc.
- Anti-vibration press leveling mounts
- Safety light curtains
- Tonnage monitor
- Die cushion
- Knockout bar
- Feeding and coil handling systems
- Flywheel brake
- Die space light
- Anchor bolts & foundation plates
- VFD-variable frequency drive
- Quick die change system (page 4)
  - » Upper die clamp
  - » Lower die clamp
  - » Die lifter
  - » Die arm

### Stroke-Capacity Diagram ( S ) ( V )

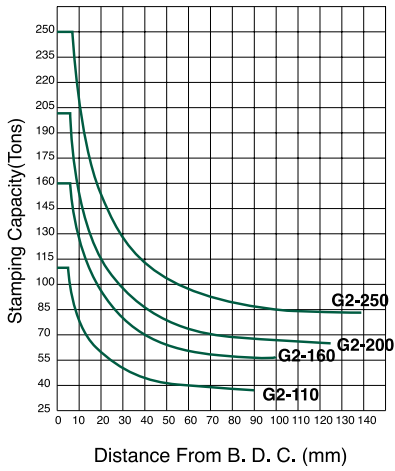

### Produce High Quality Stampings with Low Deflection, Ultra-Rigid Steel Frame

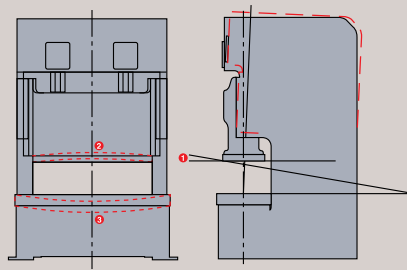

The Stamtec G2 Series is designed to resist deflection, and to provide accurate pressings and longer die life, even at full tonnage loads. The heavy, one-piece welded steel frame is fully stress relieved to provide a stable base for the G2 Series presses.

### Get High Performance with Low Maintenance, Long-Life Wet Clutch and Brake

The Stamtec clutch delivers high torque at relatively low air pressure, and with a low moment of inertia. Modern, suited clutch and brake friction linings combine high performance with low vibration and noise. The linings run in an enclosed oil bath, providing very efficient heat dissipation. Together, these superior features add up to a high performance, efficient, long-lived clutch, with reduced lining wear and air consumption, even at high single-stroke rates of production.

### Stroke-Capacity Diagram ( H )

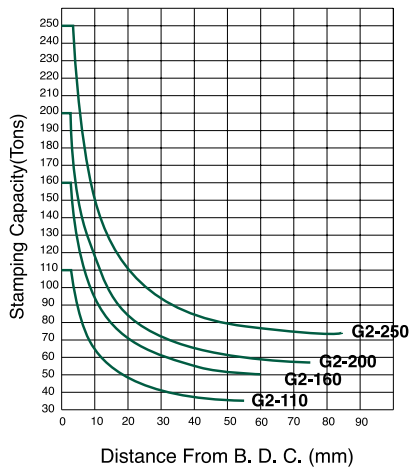

1. Frame
2. Flywheel
3. Pinion Shaft
4. Wet Type Clutch & Brake
5. Main Gear
6. Crank Shaft
7. Counter Balance
8. Connecting Rod
9. Adjusting Screw
10. Chamber of H.O.L.P.
11. Slide
12. Slide Plate (detachable)
13. Bolster

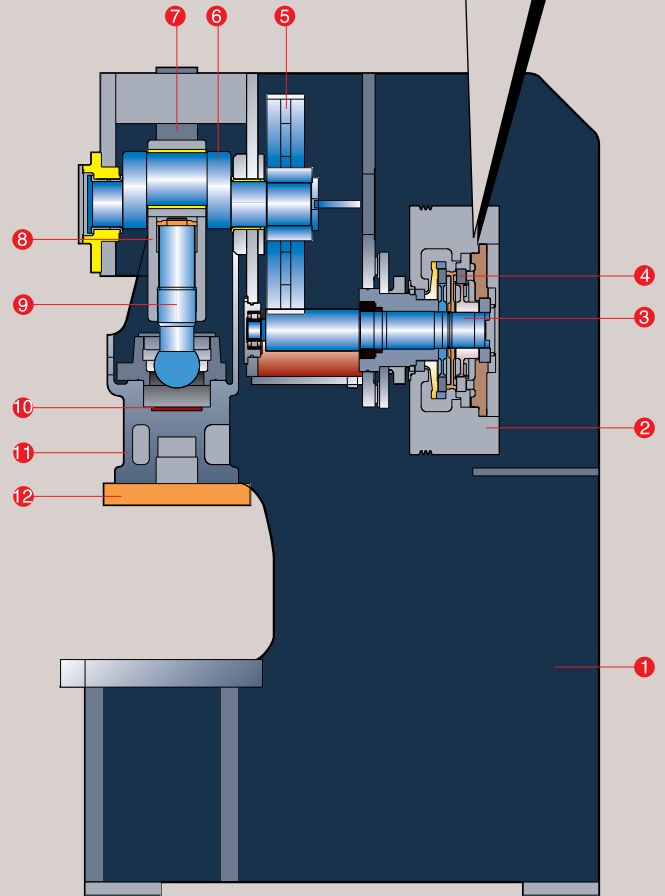

### Assure Accurate Vertical Force with Centered Box-Type Gibbing

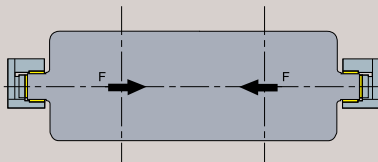

One-piece, full-length, box-type centered gibs assure actuated slide guiding, and provides better control of slide alignment than rear-mounted gibs. Force is delivered vertically, minimizing lateral thrust and, consequently reducing off-center loading and friction in the gibs. Clearance settings (front to back and left to right) are accomplished by push-pull types screws, and maintained to factory tolerances by the use of laminated spacers.

### Protect Press and Dies with Fast Response HOLP

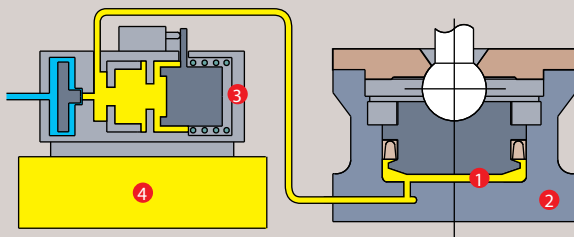

Stamtec's fast response Hydraulic Overload Protection (HOLP) system relieves the pressure of a tonnage overload in milliseconds and simultaneously issues an emergency stop signal to the press control, protecting the press and tooling from catastrophic damage. The HOLP system automatically re-pressurizes when the slide is inched back to top of stroke. The HOLP system can also be relieved manually to assist in un-sticking a die which is stuck on bottom of stroke.

### Maintain Parallelism During Off Center Loads

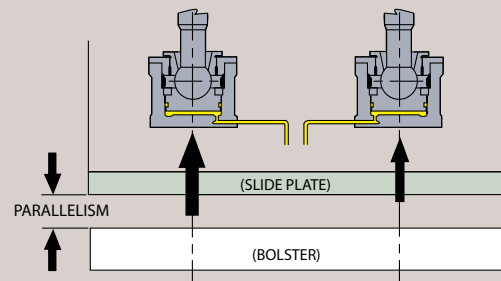

If unequal loads are applied across the slide, full oil pressure from the overload system is applied where required to retain the parallelism between slide plate and bolster for consistent quality of stampings and extended tooling life.

**SPECIFICATIONS - IMPERIAL**

MODEL		G2-110		G2-160		G2-200		G2-250	
Type		V	H	V	H	V	H	V	H
Capacity	Tons	121		176		220		275	
Rated tonnage point (above B. D. C.)	in.	0.196	0.118	0.236	0.118	0.236	0.118	0.275	0.137
Stroke length	in.	7.08	4.33	7.87	5.11	9.84	5.9	11.02	6.69
Strokes per minute	SPM	30~65	50~100	30~55	40~85	25~45	35~70	20~35	30~60
Die height (S. D. A. U.)	in.	15.75		17.71		19.68		21.65	
Maximum upper die weight	lbs.	1,763.69		2,799.86		3,240.79		3,439.20	
Slide adjustment	in.	3.93		3.93		4.72		4.72	
Bolster area (L. R. x F. B.)	in.	70.86 x 25.59		78.73 x 29.92		94.48 x 33.07		106.29 x 35.43	
Bolster thickness	in.	5.11	6.49	5.90	7.28	6.29	8.26	6.29	8.46
Slide plate area (L. R. x F. B.)	in.	55.11 x 19.68		62.99 x 21.65		72.83 x 25.59		82.67 x 27.55	
Slide plate thickness	in.	2.75		2.75		3.74		3.74	
Shank hole	in.	ø1.96 x .11 Pitch 12.59		ø1.96 x .11 Pitch 13.77		ø1.96 x .11 Pitch 147.6		ø1.96 x .11 Pitch 17.71	
Main motor	HP x P	10 x 6		15 x 6		20 x 6		25 x 6	
	kW x P	7.5 x 6		11 x 6		15 x 6		19 x 6	
Slide adjusting motor	HP x P	1 x 4		1 x 4		2 x 4		2 x 4	
	kW x P	.75 x 4		.75 x 4		1.5 x 4		1.5 x 4	
Air supply pressure	PSI	71.12		71.12		71.12		71.12	
<b>DIE CUSHION 2 - PAD - 2 - CYLINDER</b>									
Capacity	lbs.	7,936.64 x 4,409.24		13,889.12 x 4,409.24		22,046.23 x 4,409.24		30,864.72 x 4,409.24	
Air pressure	PSI	92.45		102.41		96		128.01	
Stroke length	in.	2.755		2.755		3.14		3.14	
Pad area	in.	13.77 x 8.46 x 2pcs		16.14 x 10.23 x 2pcs		21.25 x 13.77 x 2pcs		25.19 x 18.50 x 2pcs	

**SPECIFICATIONS - METRIC**

MODEL		G2-110		G2-160		G2-200		G2-250	
Type		V	H	V	H	V	H	V	H
Capacity	Tons	110		160		200		250	
Rated tonnage point (above B. D. C.)	in.	5	3	6	3	6	3	7	3.5
Stroke length	in.	180	110	200	130	250	150	280	170
Strokes per minute	SPM	35~65	50~100	30~55	40~85	25~45	35~70	20~35	30~60
Die height (S. D. A. U.)	in.	400		450		500		550	
Maximum upper die weight	lbs.	800		1270		1470		1560	
Slide adjustment	in.	100		100		120		120	
Bolster area (L. R. x F. B.)	in.	1800 x 650		2000 x 760		2400 x 840		2700 x 900	
Bolster thickness	in.	130	165	150	185	160	210	160	215
Slide plate area (L. R. x F. B.)	in.	1400 x 500		1600 x 550		1850 x 650		2100 x 700	
Slide plate thickness	in.	70		70		95		95	
Shank hole	in.	ø50 x 3 x Pitch 320		ø50 x 3 x Pitch 350		ø50 x 3 x Pitch 3750		ø50 x 3 x Pitch 450	
Main motor	HP x P	10 x 6		15 x 6		20 x 6		25 x 6	
	kW x P	7.5 x 6		11 x 6		15 x 6		19 x 6	
Slide adjusting motor	HP x P	1 x 4		1 x 4		2 x 4		2 x 4	
	kW x P	.75 x 4		.75 x 4		1.5 x 4		1.5 x 4	
Air supply pressure	PSI	5		5		5		5	
<b>DIE CUSHION 2 - PAD - 2 - CYLINDER</b>									
Capacity	lbs.	3.6 x 2		6.3 x 2		10 x 2		14 x 2	
Air pressure	PSI	6.5		7.2		6.75		9	
Stroke length	in.	70		70		80		100	
Pad area	in.	350 x 215 x 2pcs		410 x 260 x 2pcs		504 x 350 x 2pcs		640 x 470 x 2pcs	

# Smart

## Micro-Processor Press Control System

### MPC-3000 Series

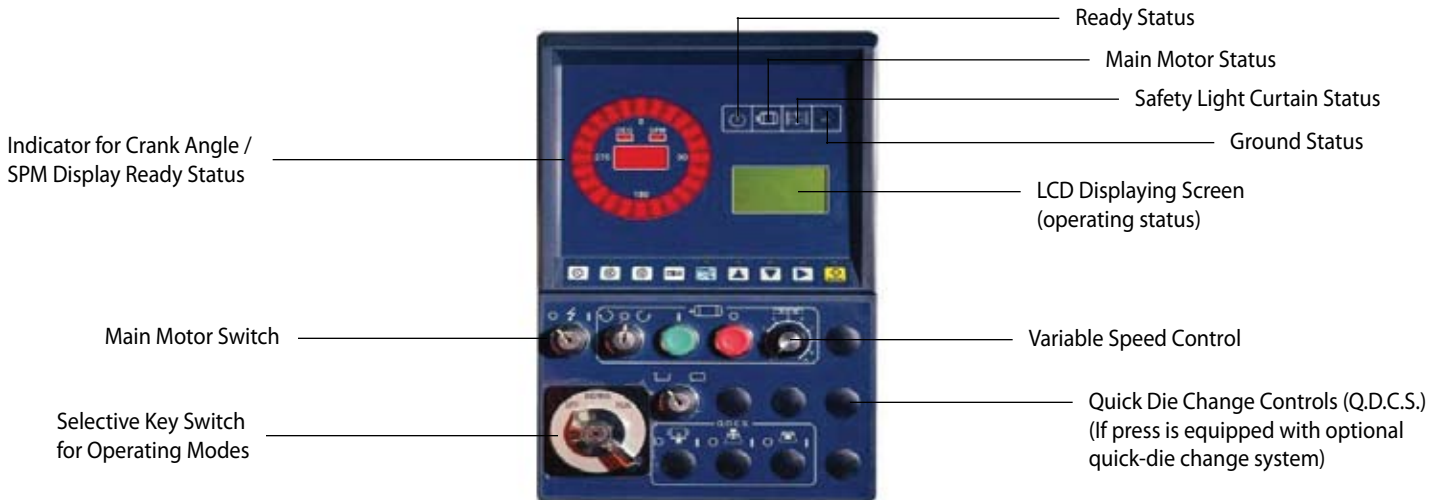

**MAIN OPERATION PANEL**

#### I. Operation Status Monitoring

- 1-Motion detection monitor broken shaft, crankshaft, excessive wear of lining, engagement and disengagement of clutch and brake device.
- 2-Motor status (Forward / Reverse / Consumption / SPM) displayed on LCD displaying screen, with the setting function.
- 3-Dual-circuit protection for safety light curtain and overrun.
- 4-Panel-displaying operation modes and error messages with trouble -shooting instruction

#### II. Electronic Angle Control

- 1-Panel setting cam ON / OFF angle from LCD displaying screen.
- 2-6-spare cams as standard, and increase of space cams can be added as options without mechanical modifications.
- 3-Brake monitor is equipped with automatic slip-angle correction within a limited range against inaccurate TDC stop position caused by wear and change of slide speed.

#### III. Counter

- 1-Total counter, pre-set counter, chop counter, maintenance counter, and Life counter are all provided.
- 2-Setting figures and status of counters all displayed from LCD displaying screen.

#### IV. Provision of interface for peripheral equipment

- 1-Cam angle controlled misfeed detection circuits A1 & B1 can be set for ON / OFF, and A2 & B2 can be set for all-time detection. A and B port can be set individually.
- 2-RS-485 module as option for the telegraph-communication monitoring and controlling.

**Customer specified optional controls available from Allen Bradley, Honeywell Wintriss, Link Siemens, Mitsubishi, etc.**

#### QUICK DIE CHANGE SYSTEM (Q.D.C.S.)

Option	Qty	Model	GTX-160	GTX-200	GTX-250	GTX-300	GTX-400	
Die Clamp	Upper	TX-2 or TY-2	Clamping Force	2 tons/pc	8	8		
		TX-4 or TY-4	Clamping Force	4 tons/pc			8	8
		TX-6 or TY-6	Clamping Force	6 tons/pc				
	Lower	TX-2 or TY-2	Clamping Force	2 tons/pc	8	8		
		TX-4 or TY-4	Clamping Force	4 tons/pc			8	8
		TX-6 or TY-6	Clamping Force	6 tons/pc				
Die Lifter	DL28-600	Pay Load	1.4 tons/pc					
	DL28-700	Pay Load	1.5 tons/pc	4				
	DL28-800	Pay Load	1.6 tons/pc					
	DL28-900	Pay Load	1.8 tons/pc		4	4	4	
Die Arm	RC-700-600	Pay Load	600 kg/pc	4				
	RC-800-800	Pay Load	800 kg/pc					
	RC-900-900	Pay Load	900 kg/pc		4	4	4	
Hydraulic Power Unit FP6308U				1				

#### Die Clamp TX-type

With "U" Cut in die set

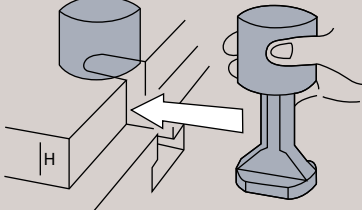

#### Die Clamp TY-type

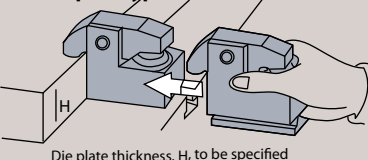

Die plate thickness, H, to be specified

(The suggested selections are for reference only. Actual item selection may vary subject to requirements.)

## OUTLINE DIMENSIONS

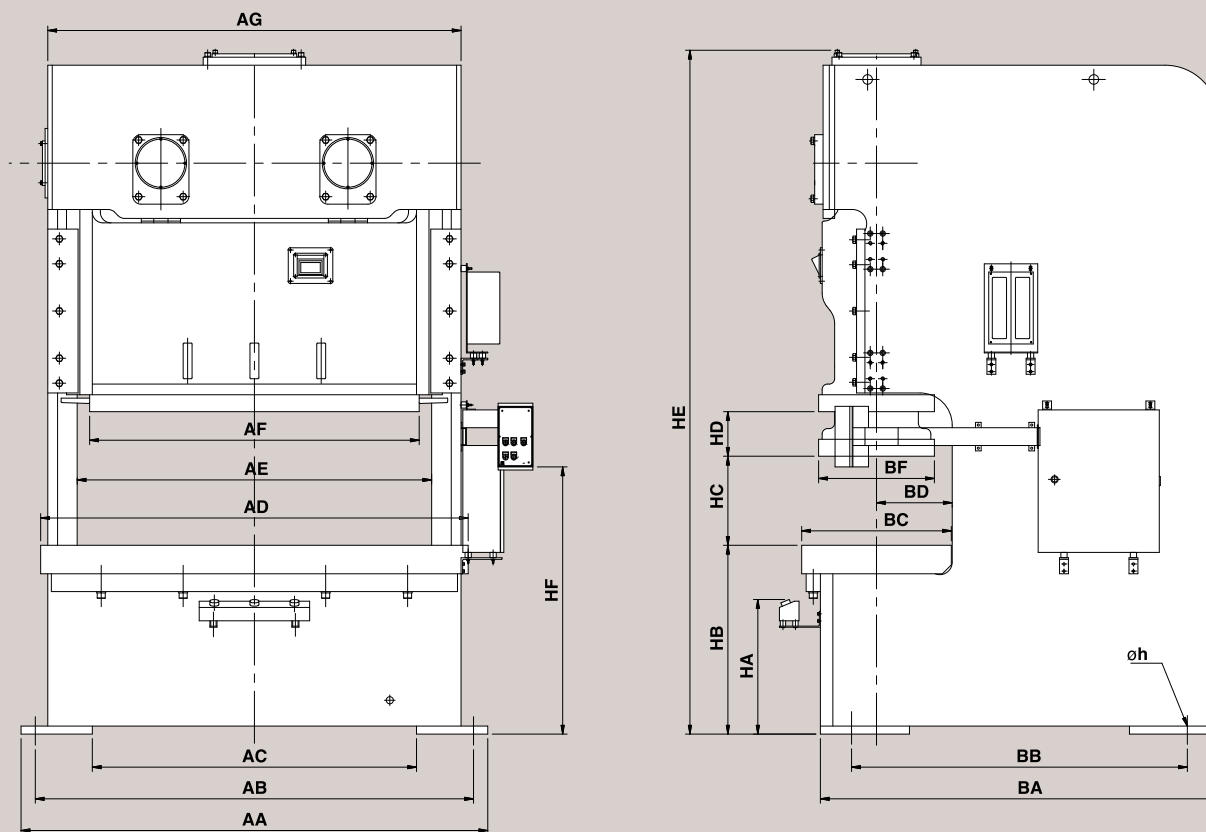

unit: mm

MODEL	G2-110			G2-160			G2-200			G2-250		
TYPE	S	V	H	S	V	H	S	V	H	S	V	H
AA	2000 mm / 78.74 in			2200 mm / 86.61 in			2620 mm / 103.15 in			3000 mm / 118.10 in		
AB	1900 mm / 74.80 in			2080 mm / 81.89 in			2460 mm / 96.85 in			2800 mm / 110.23 in		
AC	1360 mm / 53.54 in			1520 mm / 59.84 in			1820 mm / 71.65 in			2200 mm / 86.61 in		
AD	1800 mm / 70.87 in			2000 mm / 78.74 in			2400 mm / 94.48 in			2700 mm / 106.29 in		
AE	1510 mm / 59.44 in			1660 mm / 65.35 in			1990 mm / 78.34 in			2230 mm / 87.79 in		
AF	1400 mm / 55.11 in			1600 mm / 62.99 in			1850 mm / 72.83 in			2100 mm / 82.67 in		
AG	1780 mm / 70.07 in			1980 mm / 77.95 in			2320 mm / 91.33 in			2590 mm / 101.96 in		
BA	1745 mm / 68.70 in			1940 mm / 76.37 in			2235 mm / 87.99 in			2545 mm / 100.19 in		
BB	1295 mm / 50.98 in			1380 mm / 54.33 in			1885 mm / 74.21 in			2195 mm / 86.41 in		
BC	650 mm / 25.59 in			760 mm / 29.92 in			840 mm / 33.07 in			900 mm / 35.43 in		
BD	330 mm / 12.99 in			385 mm / 15.15 in			425 mm / 16.73 in			455 mm / 17.91 in		
BE	500 mm / 19.68 in			550 mm / 21.65 in			650 mm / 25.59 in			700 mm / 27.55 in		
HA	(595 mm) / (23.42 in)			(695 mm) / (27.36 in)			(755 mm) / (29.72 in)			(785 mm) / (30.90 in)		
HB	830 mm / 32.67 in	865 mm / 34.05 in		990 mm / 38.97 in	1025 mm / 40.35 in		1060 mm / 41.73 in	1110 mm / 43.70 in		1090 mm / 42.91 in	1145 mm / 45.07 in	
HC	400 mm / 15.74 in			450 mm / 17.71 in			500 mm / 19.68 in			550 mm / 21.65 in		
HD	180 mm / 7.08 in	110 mm / 4.33 in		200 mm / 7.87 in	130 mm / 5.11 in		250 mm / 9.84 in	150 mm / 5.90 in		280 mm / 11.02 in	170 mm / 6.69 in	
HE	3059 mm / 120.43 in			3709 mm / 146.02 in			3839 mm / 151.14 in			4294 mm / 169.05 in		
HF	1170 mm / 46.06 in			1370 mm / 53.93 in			1500 mm / 59.05 in			1610 mm / 63.38 in		
ØF	Ø35 mm / 1.38 in			Ø47 mm / 1.85 in			Ø54 mm / 2.12 in			Ø54 mm / 2.12 in		

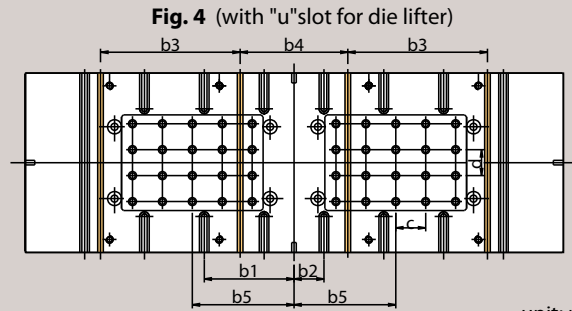
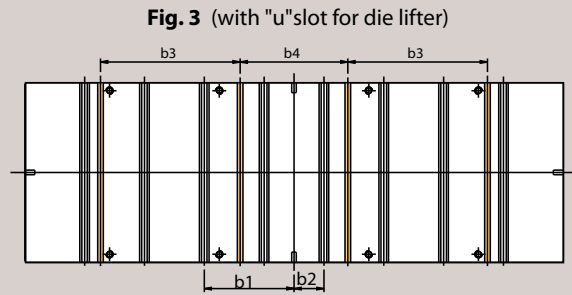
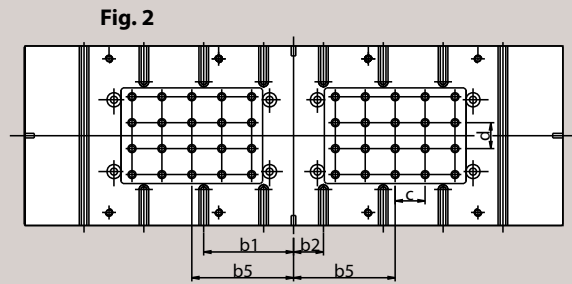
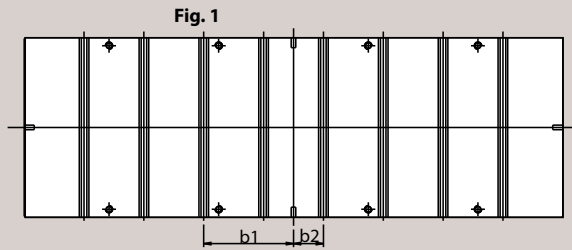

unit: mm

MODEL	G2-110	G2-160	G2-200	G2-250	
Bolster Area (LR x FB)	1800 x 650 mm / 70.86 x 25.59 in	2000 x 760 mm / 78.74 x 29.92 in	2400 x 800 mm / 94.48 x 33.07 in	2700 x 900 mm / 106.29 x 35.43 in	
Type of T-Slot	A	A	A	A	
No. of T-Slot	6	8	8	8	
b1	375 mm / 14.76 in	375 mm / 14.76 in	375 mm / 14.76 in	450 mm / 17.72 in	
b2	125 mm / 4.92 in	125 mm / 4.92 in	125 mm / 4.92 in	150 mm / 5.91 in	
b3	320 mm / 12.6 in	520 mm / 20.47 in	710 mm / 27.96 in	680 mm / 26.77 in	
b4	430 mm / 16.93 in	520 mm / 20.47 in	520 mm / 20.47 in	540 mm / 21.26 in	
b5	255 mm / 10.04 in	415 mm / 16.34 in	455 mm / 17.91 in	510 mm / 20.08 in	
Fig 2, Fig 4	No. of Pin Hole x Dia.	30 x 20 mm / 1.81 x 0.79	48 x 20 mm / 1.89 x 0.79 in	48 x 28 mm / 1.89 x 0.79 in	70 x 28 mm / 2.76 x 0.79 in
	C x D	75 x 100 mm / 2.95 x 3.94 in	75 x 75 mm / 2.95 x 2.95 in	100 x 100 mm / 3.94 x 3.94 in	100 x 100 mm / 3.94 x 3.94 in

SLIDE PLATE

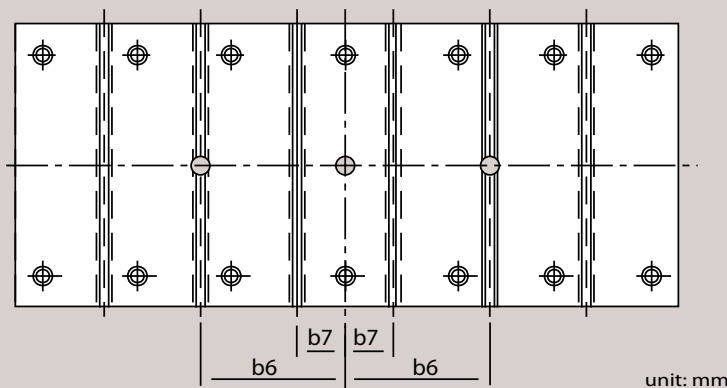

unit: mm

T-Slot Detail

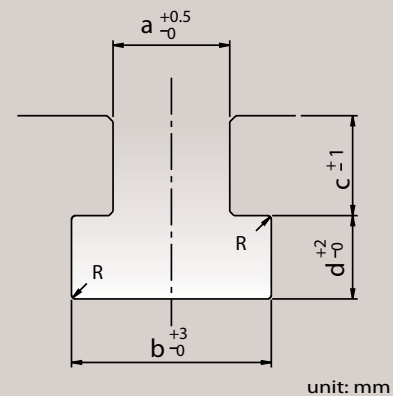

unit: mm

MODEL	G2-110	G2-160	G2-200	G2-250
Slide Plate Area (LR x FB)	1400 x 500 mm 55.12 x 19.68 in	1600 x 550 mm 62.99 x 21.65 in	1850 x 650 mm 72.83 x 25.59 in	2100 x 700 mm 82.67 x 27.56 in
Type of T-Slot	A	A	B	B
No. of T-Slot	4	6	6	6
b6	375 mm / 14.76 in	375 mm / 14.76 in	375 mm / 14.76 in	450 mm / 17.72 in
b7	125 mm / 4.92 in	125 mm / 4.92 in	125 mm / 4.92 in	150 mm / 5.91 in

Dim.	Type	A	B
a		22 mm / 0.087 in	28 mm / 1.10 in
b		37 mm / 1.46	48 mm / 1.89 in
c		24 mm / 0.98 in	28 mm / 1.10 in
d		16 mm / 0.63 in	20 mm / 0.79 in
r		1 mm / 0.04 in	1 mm / 0.04 in



# STAMTEC®

MECHANICAL PRESSES

Stamtec has been providing dependable, affordably priced metal stamping presses for almost 25 years in the North American market, and 60 years worldwide through our parent company. Our 72,000 sq. ft. sales, service, logistics, and assembly facility in Tennessee is home not only to North America's largest inventory of new presses and spare parts, but also our most important asset- our people. Our staff of engineering, sales, service, and support personnel are here to serve you in the most timely and professional manner. So, tap into our global strength, and grow with us as we grow with you!



## OCP SERIES

1-POINT GAP



## GTX SERIES

2-POINT STRAIGHT SIDE



## S2 SERIES

STRAIGHT SIDE



## COIL FEEDING & HANDLING SYSTEMS

# STAMTEC®

MECHANICAL PRESSES

U.S.A. - STAMTEC, INC.  
4160 Hillsboro Highway | Manchester, TN 37355, U.S.A.  
TEL: +1-931-393-5050 | FAX: +1-931-393-5060  
URL: [www.stamtec.com](http://www.stamtec.com)

