

## FEATURES

- Features patent-pending “high tech” packings:
  - dynamic low-pressure seal retainer
  - superior low-pressure seal
  - innovative intermediate ring
  - superior high-pressure seal
- New ceramic plunger design improves thermal shock resistance
- 316 Stainless Steel wetted parts
- 316 Stainless Steel forged manifold with exclusive lifetime warranty
- 316 Stainless Steel inlet/outlet valve plugs with improved hydrostatic performance
- Fully anodized crankcase
- Designed for reverse osmosis, misting, and for use in industrial plant systems where hot water is required

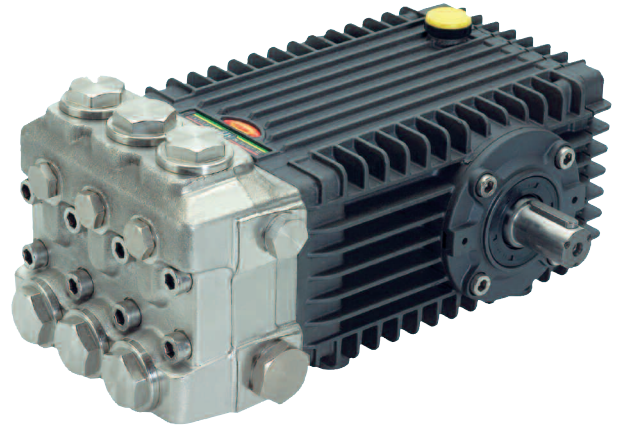

## SPECIFICATIONS

Pump Model	TSF2019SS	TSF2021SS	TSF2221SS	TSF2421SS
Maximum Volume	7.6 GPM	8.5 GPM	10.2 GPM	12.0 GPM
Maximum Discharge Pressure	3000 PSI			
Horsepower	15.6 EBHP	21.0 EBHP	21.0 EBHP	20.5 EBHP
Maximum Pump Speed	1750 RPM			
Maximum Inlet Pressure	115 PSI			
Maximum Inlet Vacuum	9 ft. water (7.9 in Hg)			
Plunger Bore (in / mm)	.787 / 20		.866 / 22	.945 / 24
Plunger Stroke (in / mm)	.748 / 19	.826 / 21		
Oil Capacity	40.6 oz			
Maximum Fluid Temperature	185°F			
Inlet Port Thread	3/4-14 BSP-F			
Discharge Port Thread	3/8-19 BSP-F			
Shaft Diameter (in / mm)	0.9449 / 24			
Weight	42.0 lbs / 15.7 kg			
Dimensions	13.4 x 9.8 x 7.5 in			

TRIPLEX

TRIPLEX



General Pump  
is a member of  
the Interpump Group



# Instructions and Recommendations for the Installation of 66 Series TSF-SS

The high-temperature pumps of the 66, TSF-SS series have been designed for use in applications where the water must be pre-heated, such as in car-wash, food and pharmaceutical industries.

Maximum temperature of the water through the pump is 185°F (85°C).

In order to obtain maximum performance in terms of duration of seals and valves, it is necessary to respect a few simple rules, as follows:

**1) In order to avoid damage caused by cavitation, the pump must be pressure fed.**

The higher the inlet pressure, the longer the life of the wet end of the pump.

When working at 185°F (85°C), the minimum feed pressure - measured directly in the inlet port of the pump when it is working - is 45 psi (3 bar).

The minimum feed pressure according to the different temperatures are:

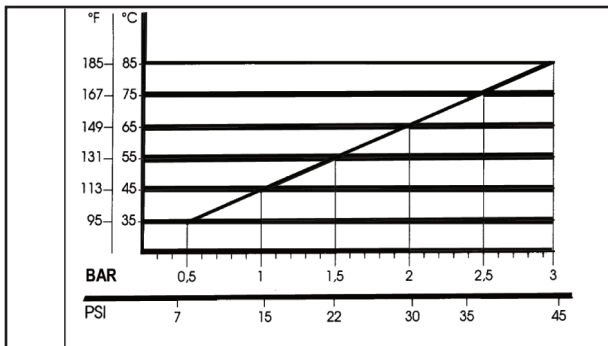

Naturally, if the application allows for feeding the pump with 45 psi (3 bar) even at low temperatures (for example: 115°F/45°C the life of the wet end of the pump will be even longer.

**2) The plumbing which feeds the pump must be of a diameter at least equal to the inlet port.**

Also, follow the suggestions below:

a) Make the plumbing as short and straight as possible, preferably in an upward direction to facilitate the expulsion of eventual air bubbles naturally if compatible with the requirements of the system.

b) It is always useful to put a filter at the inlet with capacity of 4 to 5 times the flow of

the pump, for example for a 4 gpm (15 l/min) pump, put a filter from 16 to 20 gpm (60-75 l/min). The mesh size suitable for this application is 0.016" (.4 mm).

c) It is extremely important to put a pressure switch on the suction port of the pump, and in any case downstream from the filter, so that it can stop the pump should the feed pressure drop by 20% due to the filter clogging or failure of the feed pump, etc.

**3) Change of oil**

We recommend the **first oil change after the first 50 hours**, with the **pump stopped** and the **oil still warm**.

This change is not recommended because the oil has lost its properties, but rather to eliminate the impurities that have gotten into the oil during the running-in phase. If these impurities are not removed, but are allowed to remain in the oil, they *may cause premature wear* to the moving parts and the oil seals. **After this initial change, the oil can then be changed every three months or 300 hours of operation thereafter.**

Please note: If the pump works in conditions with high humidity and with sharp temperature changes, it is possible that condensation will appear inside the crankcase, which mixing with the oil can change its properties. This is easy to see because the oil changes to a white, milky color.

If the pump does not have excessive water leaking from the packings, and the oil becomes milky, the oil has to be changed more frequently. The percentage of water in the oil must not exceed 20%.

**Use oil per the following chart:**

CHART OF COMPATIBLE OILS SAE15W40	
GENERAL PUMP	SERIES 100
BP	VISCO 2000
CASTROL	CWX
MOBIL	SUPER
SHELL	HELIX SUPER
TOTAL	QUARTZ 4000-5000

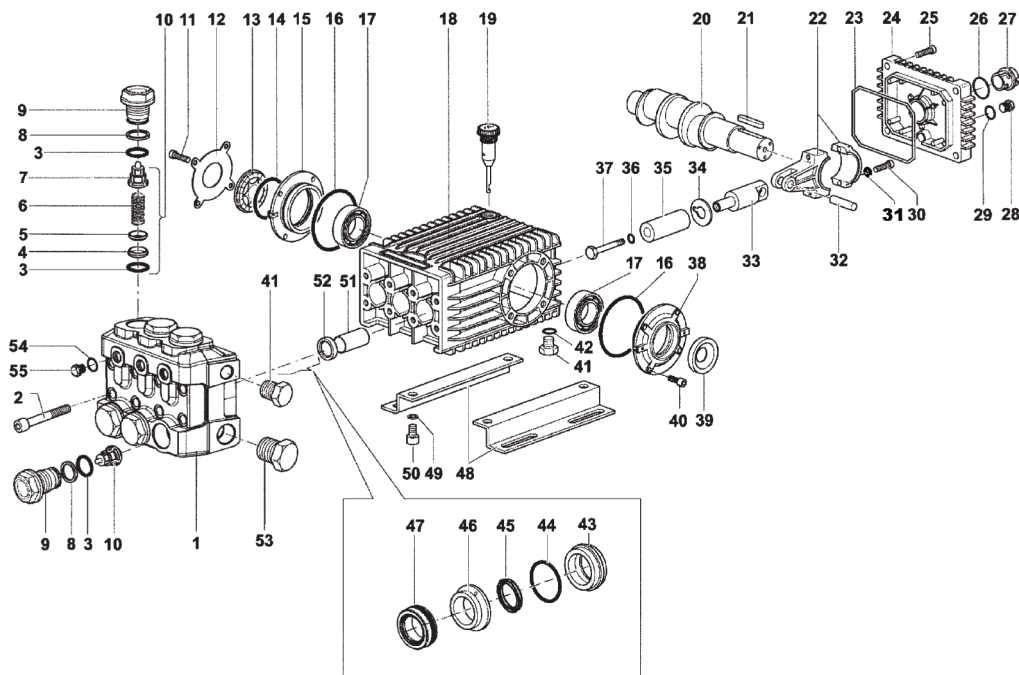

**PARTS LIST**

ITEM	PART NO.	DESCRIPTION	QTY	ITEM	PART NO.	DESCRIPTION	QTY	ITEM	PART NO.	DESCRIPTION	QTY
1.	66120336	Manifold, 20mm, 316SS	1	21.	91489200	Key	1	41.	98210066	Plug, 3/8", SS	2
	66120436	Manifold, 22mm, 316SS		22.	66030001	Connecting Rod	3	42.	90383300	O-ring	1
	66120536	Manifold, 24mm, 316SS		23.	90392200	O-ring	1	43.	66081766	Seal Retainer, 20mm, SS	3
2.	99380200	Head Bolt, M10	8	24.	66160022	Crankcase Cover, Rear	1	66081866	Seal Retainer, 22mm, SS		
3.	90385700	O-ring	12	25.	99188300	Screw, M6	4	66081966	Seal Retainer, 24mm, SS		
4.	36203766	Valve Seat, SS	6	26.	90405100	O-ring	1	44.	90361600	O-ring	3
5.	36203476	Valve Poppet, SS	6	27.	63210051	Oil Level Indicator	1	45.	90225000	L.P. Seal, 20mm	3
6.	94738800	Valve Spring, SS	6	28.	98204000	Plug, 1/4"	1	90230000	L.P. Seal, 22mm		
7.	36203551	Valve Guide	6	29.	90358500	O-ring	4	90235000	L.P. Seal, 24mm		
8.	90516500	Anti-Ext. Ring	6	30.	99309900	Screw, M8	6	46.	66217266	Intermed. Ring, 20mm, SS	3
9.	66130266	Valve Cap, SS	6	31.	96701400	Lock Washer, M8.4	6	66217366	Intermed. Ring, 22mm, SS		
10.	36713101	Valve, Complete	6	32.	97740500	Wrist Pin	3	66217466	Intermed. Ring, 24mm, SS		
11.	99307000	Screw, M8x25, SS	4	33.	66050064	Plunger Guide	3	47.	90226000	H.P. Seal, 20mm	3
12.	66150366	Cover, SS	1	34.	96709800	Flinger Washer, SS	3	90231200	H.P. Seal, 22mm		
13.	44211801	Sight Glass	1	35.	66040009	Plunger, 20mm	3	90236000	H.P. Seal, 24mm		
14.	90409700	O-ring	1		66040109	Plunger, 22mm		48.	47200074	Pump Rail	2
15.	66150122	Cover, Side	1		66040409	Plunger, 24mm		49.	96710600	Washer, M10	4
16.	90391300	O-ring	2	36.	90358400	O-ring	3	50.	99364400	Screw, M10	4
17.	91838000	Bearing, Cyl. Roller	2	37.	66219666	Plunger Bolt, SS	3	51.	90912600	Guide Bushing	3
18.	66010022	Crankcase	1	38.	66150022	Cover, Side	1	52.	90162500	Plunger Rod Oil Seal	3
19.	98210600	Oil Dip Stick	1	39.	90164800	Crankshaft Seal	1	53.	98226600	Plug, G3/4", SS	1
20.	66020035	Crankshaft, 19 mm Stroke	1	40.	99303800	Screw, M8	4	54.	90358500	O-ring	4
	66020435	Crankshaft, 21 mm Stroke	1					55.	98204600	Plug, G1/4", SS	3

**REPAIR KITS**

Kit No.	K02	K03	K228	K206 (Ø20mm)	K217 (Ø20mm)	K208 (Ø22mm)	K218 (Ø22mm)	K210 (Ø24mm)	K219 (Ø24mm)
Item No's Included in Kit	52	39	3, 4, 5, 6, 7 (10)	45, 47	43, 44 45, 46, 47	45, 47	43, 44 45, 46 47	45, 47	43, 44, 45, 46 47
Number of Assemblies In Kit	3	2	6	3	1	3	1	3	1
Number of Cylinders Kit Services	3	-	3	3	1	3	1	3	1

**TORQUE SPECS\***

Position	Ft.-Lbs.	Nm.
2	33.2	45
9	95.9	130
11	14.8	20
25	7.4	10
28	14.8	20
30	14.8	20
37	14.8	20
40	14.8	20
41	29.5	40
50	29.5	40
53	51.6	70
55	29.5	40

\*Decrease torque by 20% if threads are lubricated.

\*\*Use Loctite 542

**DIMENSIONAL DRAWING**

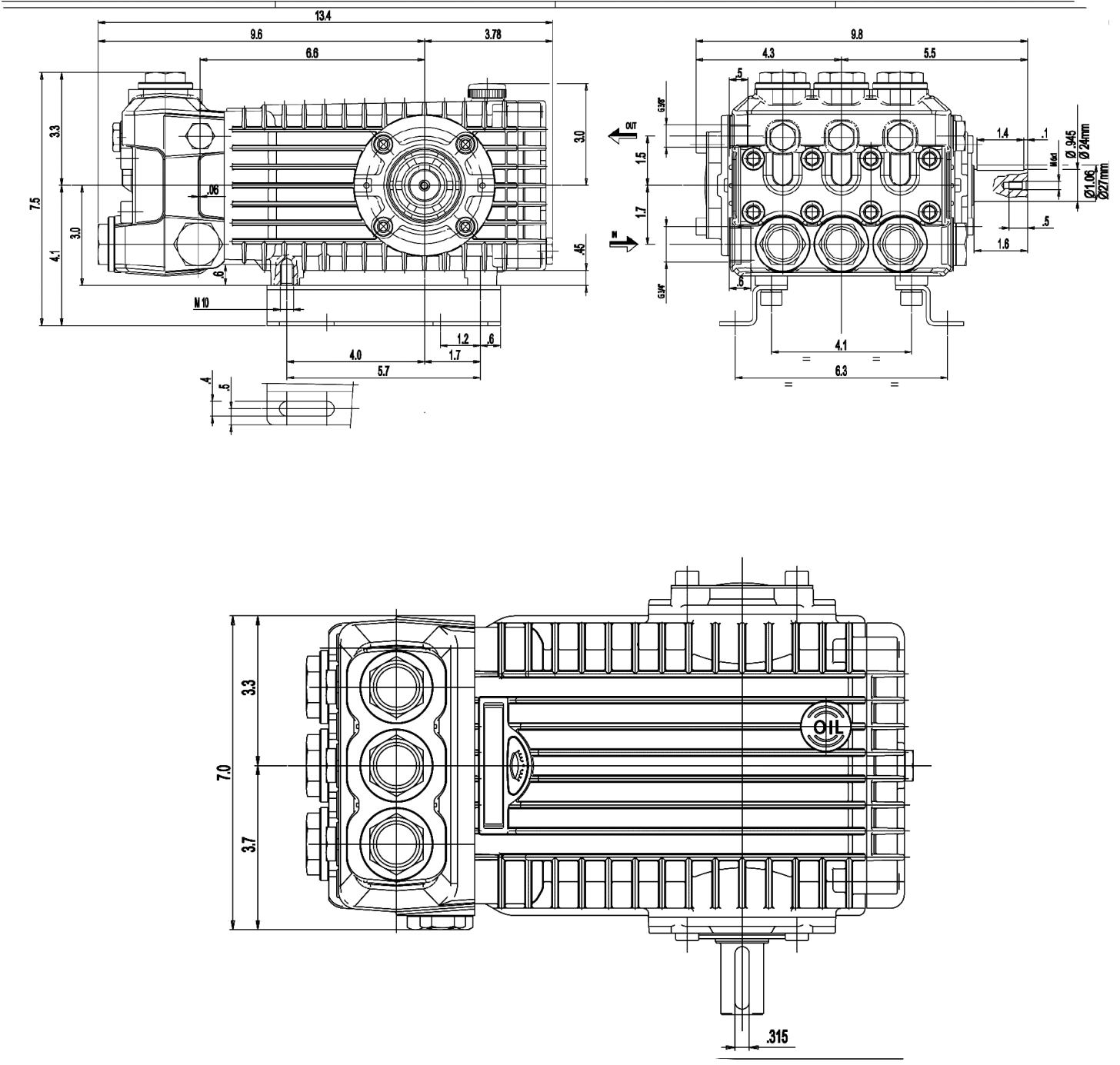

Ref 300575 Rev. C  
03-11