

KFZ Series

FEATURES

- High pressure, Triplex Plunger pump
- Patent pending, symmetrical power end design featuring top and bottom mounting holes allowing for easy left to right shaft conversion
- Low-high pressure packing design with integrated cooling system
- High volumetric efficiency suction/delivery valves featuring new spherical design of sealing areas
- Splash lubrication
- New high performance aluminum alloy connecting rods and a floating wrist pin enable extra load at half the weight. This reduces vibrations and off center loads on the bearing for longer life and quieter operation
- SAE-C hydraulic drive available
- Patent pending "high tech" low and high pressure seals
Solid shaft only for belt-driven applications.

MATERIALS

- High resistance light alloy crankcase
- 316 stainless steel manifold
- Taper roller bearings
- Special antifriction light alloy, forged, connecting rods
- Forged alloy steel crankshaft, hardened, tempered and nitrided
- Cast iron piston guide, nickel treated
- Solid ceramic plungers
- 316 stainless steel valves

Product Group: V



COMMON SPECIFICATIONS

- Maximum Inlet Pressure: 45 PSI
- Maximum Fluid Temperature: *185° F
- Inlet Port Thread: 1-1/2" NPT-F
- Discharge Port Thread: 1" NPT-F
- Shaft Diameter: 1.575"/40 mm
- Stroke: 1.969"/50 mm
- Pump Dimensions: 20.7" x 14.5" x 9.9"
- Crankcase Oil Capacity: 128.5 oz. (3.8 liters)
..... (use GP Series 220 Oil)
- Shipping Weight: 150 lbs./68 kg

*Please consult technical guide or GP Sales Representative for Temperature/Inlet Pressure Information.

Note: All models come standard with crankshaft on right side (when facing manifold), specify "L" when ordering left hand version.

MODEL	GPM/LPM	PSI/BAR	RPM	BORE	EBHP
KFZ28A	24.5 GPM/93 LPM	3000 PSI/207 BAR	1000 RPM	1.102 in./28 mm	50.0
KFZ30A	28.0 GPM/106 LPM	2900 PSI/200 BAR	1000 RPM	1.181 in./30 mm	55.0
KFZ36A	32.2 GPM/122 LPM	2300 PSI/160 BAR	800 RPM	1.417 in./36 mm	50.0
KFZ36A	36.2 GPM/137 LPM	2050 PSI/140 BAR	900 RPM	1.417 in./36 mm	50.0
KFZ36A	40.0 GPM/153 LPM	1900 PSI/130 BAR	1000 RPM	1.417 in./36 mm	52.0
KFZ40A	45.0 GPM/170 LPM	1600 PSI/110 BAR	900 RPM	1.575 in./40 mm	49.0

Volumes are theoretical at 100% volumetric efficiency.

PUMP OPTIONS

- "F" version features flushing option
- "G" version suitable for pumping high-temperature glycols (up to 140°F)
- Available with external gear box (direct drive only)
- SAE-J 744-C hydraulic drive bell housing and flexible couplers available



General Pump
is a member of
The Interpump Group

Ref 300739 Rev B
03-13



ACCESSORIES

REGULATORS

■ R1X

18.5-29.0 GPM
2900-8700 PSI
316 SS



SAFETY DEVICES

■ YVS23SS

5.3 GPM
2300 PSI
316SS



UNLOADERS

■ ZK3608SS

7.92 GPM
3600 PSI



■ ZKSX1

16.0 GPM
3600 PSI
316 SS



■ SX2

50.0 GPM
1450-5899 PSI



■ YVB280SS

21.0 GPM
4500 PSI



PULSATION DAMPENERS

■ YVS280SS

21.0 GPM
4500 PSI



■ A4X

16.0 GPM
3050PSI



■ A7X

16.0 GPM
3050PSI
316 SS



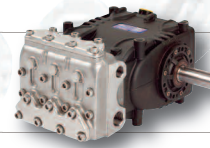

KFZ series

Technical Details

DRIVE OPTIONS

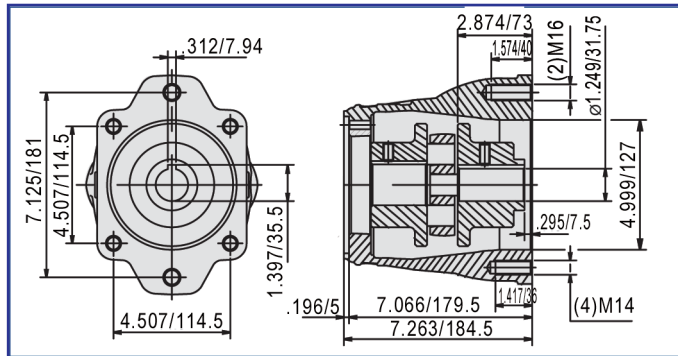

SAE-C hydraulic bell housing and flexible coupler.

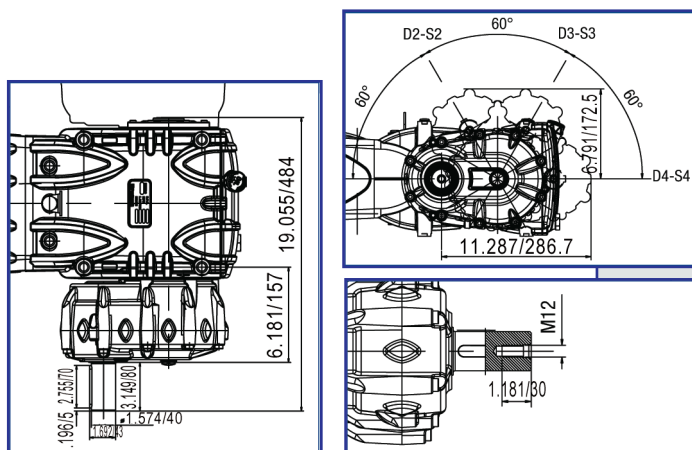

Gearbox

KFZ pumps can be supplied with an optional gearbox available in 3 different ratios. The gearbox can be mounted on the left or right side of the pump in 4 different angles, at your choice. Gearbox ratios: R=1.125:1, R=1.50:1, R=1.83:1

OVERALL DIMENSIONS

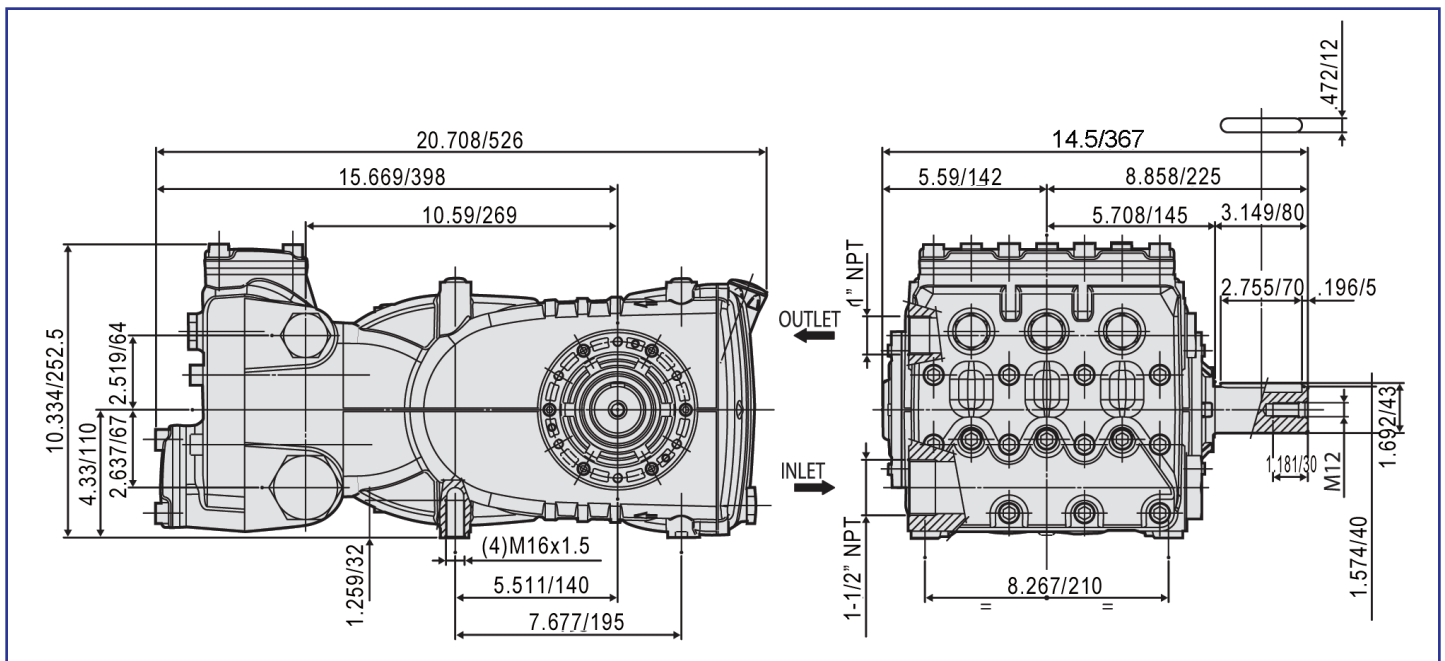

Ref 300739 Rev B
03-13