



- Standard cylinders to DIN ISO 6432
- Quick reacting thanks to minimal break-away force
- Meet the highest requirements for running characteristics, service life and load carrying ability
- Comprehensive range of accessories

Standard cylinders DSNU/ESNU, ISO 6432

Key features

FESTO

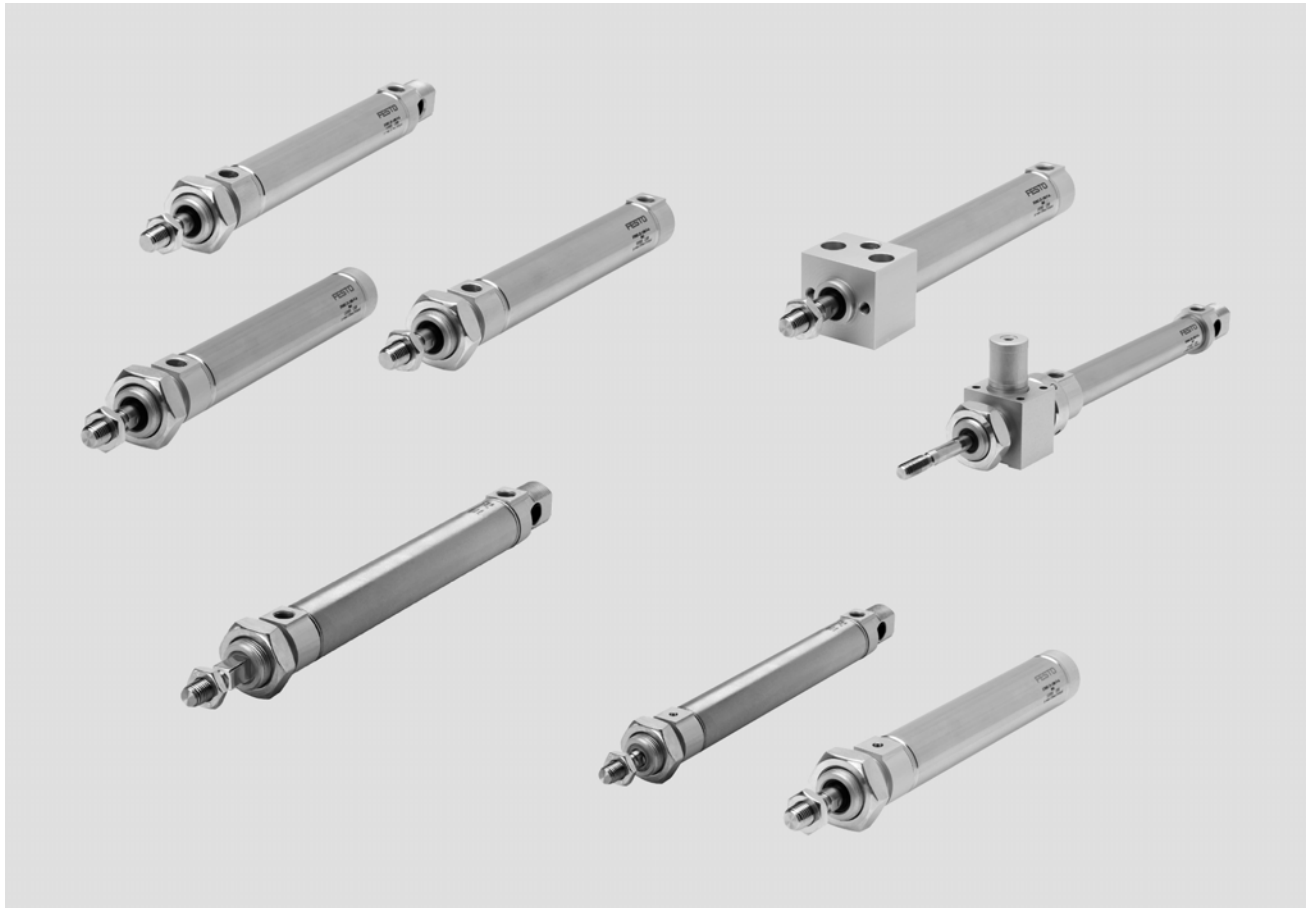

Optimal range

- Good running performance and long service life thanks to smooth, hard cylinder bore
- Piston rod and cylinder barrel made of stainless steel

More than the standard

 ISO 6432
DIN ISO 6432

 DIN

- Round cylinders with piston diameters from 8 to 25 mm conform to ISO 6432, DIN ISO 6432. Variants are based on these standards. The series is not repairable.
- The cap is swaged onto the barrel.

Functional

- Three different end caps mean numerous functional and space-saving designs

Variants

- Non-rotating
- Through piston rod
- With or without position sensing
- Cushioning non-adjustable at either end or cushioning adjustable at both ends
- Further piston rod variants

Standard cylinders DSNU/ESNU, ISO 6432

Key features

FESTO

Standard range

Double-acting

Basic version
DSNU/DSN

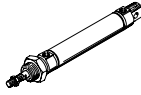

With position sensing
Cushioning non-adjustable at either end

DSNU-P-A

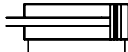

With position sensing
Adjustable cushioning at both ends

DSNU-PPV-A

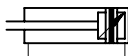

Single-acting

Basic version
ESNU/ESN

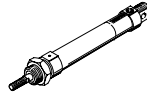

With position sensing
Cushioning non-adjustable at either end

ESNU-P-A

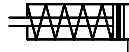

Double-acting Non-rotating

Basic version
DSNU-Q

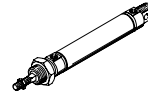

With position sensing
Cushioning non-adjustable at either end

DSNU-P-A-Q

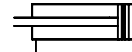

only Ø 12

With position sensing
Adjustable cushioning at both ends

DSNU-PPV-A-Q

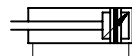

only Ø 16 ... 25

Variants from the modular system

Basic version
DSNU/ESNU

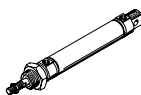

S2: Through piston rod



K8: Extended piston rod, front



Axial air connection

DSNU-MA/ESNU-MA

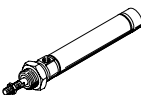

K2: Extended male piston rod thread



S6: Heat-resistant seal up to max. 150 °C



Lateral air connection

DSNU-MQ

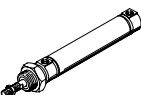

K6: Shortened male piston rod thread



S10: Slow speed (constant motion)



With direct mounting

DSNU-MH

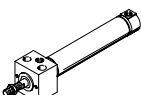

K3: Female piston rod thread



S11: Low friction



With clamping unit

DSNU-....-KP

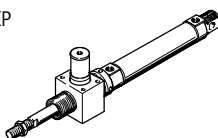

K5: Special thread on piston rod



R3: High corrosion protection



Standard cylinders DSNU, ISO 6432

Product range overview

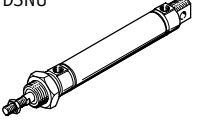
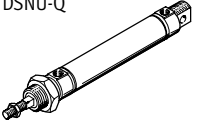
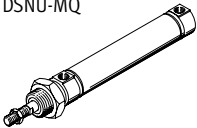
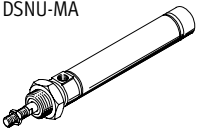
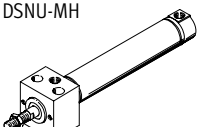

Function	Design	Cushioning		Position sensing	Piston rod					
		Fixed	Adjustable as of $\varnothing 16$		Through	Extended at front	Male thread			Female thread
		P	PPV ¹⁾		S2	K8	Extended K2	Shortened K6	Special thread K5	K3
Double-acting	Basic version with position sensing									
	DSNU 	■	■	■	■	■	■	■	■	■
	Non-rotating									
	DSNU-Q 	■ $\varnothing 12$	■ $\varnothing 16...25$	■	■	■	■	■	■	■
	Lateral air connection									
	DSNU-MQ 	■	■	■	-	■	■	■	■	■
Axial air connection										
DSNU-MA 	■	-	■	-	■	■	■	■	■	
Direct mounting										
DSNU-MH 	■	■	■	-	■	■	■	■	■	

1) for product modules as of $\varnothing 12$

Standard cylinders DSNU, ISO 6432

Product range overview

FESTO

Design	Clamping unit	Heat-resistant seal	Slow speed (constant motion)	Low friction	Corrosion protection	Piston Ø	Stroke	Variable stroke ¹⁾	→ Page
Design	KP	S6	S10	S11	R3	[mm]	[mm]	[mm]	
Basic version with position sensing									
DSNU	■	■	■	■	■	8, 10	10, 25, 40, 50,	1 ... 100	1 / 1.1-11
						12, 16	80, 100, 125,	1 ... 200	
						20	160, 200, 250,	1 ... 320	
						25	300, 320, 400,	1 ... 500	
Non-rotating									
DSNU-Q	■	-	-	-	■ Ø 16...25	12, 16	-	5 ... 160	1 / 1.1-19
						20	-	5 ... 200	
						25	-	5 ... 250	
Lateral air connection									
DSNU-MQ	■	■	-	-	■	8, 10	-	1 ... 100	1 / 1.1-11
						12, 16	-	1 ... 200	
						20	-	1 ... 320	
						25	-	1 ... 500	
Axial air connection									
DSNU-MA	■	■	-	-	■	8, 10	-	1 ... 100	1 / 1.1-11
						12, 16	-	1 ... 200	
						20	-	1 ... 320	
						25	-	1 ... 500	
Direct mounting									
DSNU-MH	-	■	-	-	■	8, 10	-	1 ... 100	1 / 1.1-11
						12, 16	-	1 ... 200	
						20	-	1 ... 320	
						25	-	1 ... 500	

1) Cylinders with position sensing require a minimum stroke of 10 mm to ensure reliable sensing.

Standard cylinders ESNU, ISO 6432

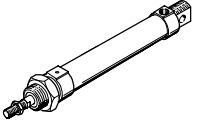
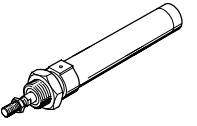

Product range overview

Function	Design	Cushioning Fixed P	Position sensing A	Piston rod					Female thread K3
				Extended at front K8	Male thread			K5	
					Extended K2	Shortened K6	Special thread		
Single- acting	Basic version with position sensing								
	ESNU 	■	■	■	■	■	■	■	
	Axial air connection								
	ESNU-MA 	■	■	■	■	■	■	■	

Standard cylinders ESNU, ISO 6432

Product range overview



Design	Piston Ø [mm]	Stroke [mm]	Variable stroke ¹⁾	→ Page
Basic version with position sensing				
ESNU	8, 10, 12, 16, 20, 25	10, 25, 50	1 ... 50	1 / 1.1-28
Axial air connection				
ESNU-MA	8, 10, 12, 16, 20, 25	–	1 ... 50	1 / 1.1-28

1) Cylinders with position sensing require a minimum stroke of 10 mm to ensure reliable sensing.

Standard cylinders DSNU/ESNU, ISO 6432

Peripherals overview

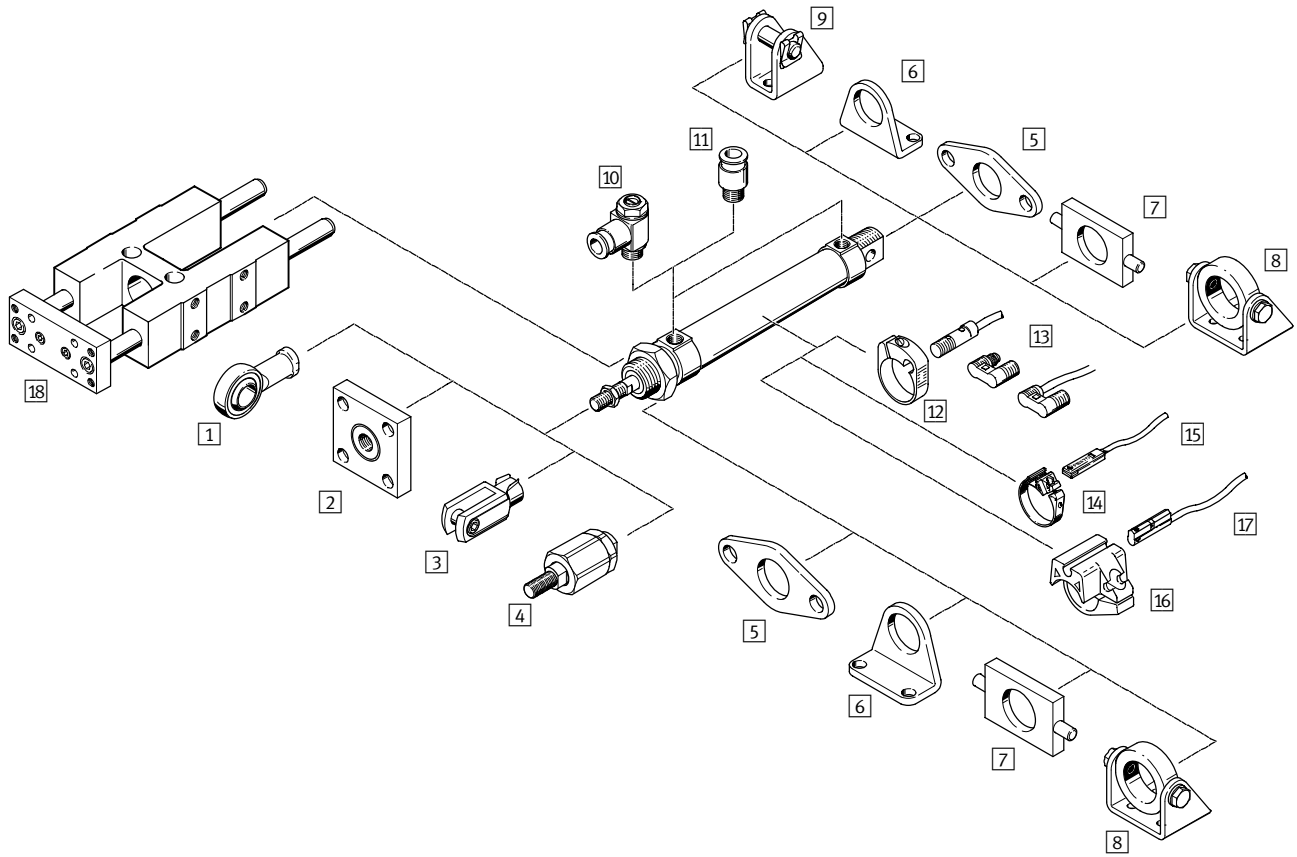

Variants

DSNU-MQ

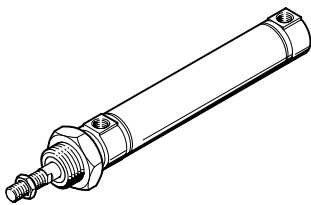

DSNU-MA

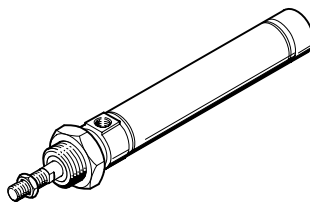

DSNU-MH

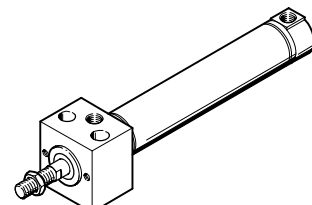

DSNU-Q

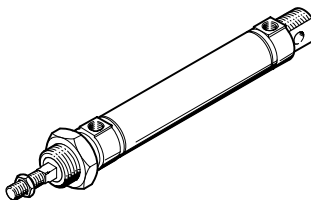

DSNU-KP

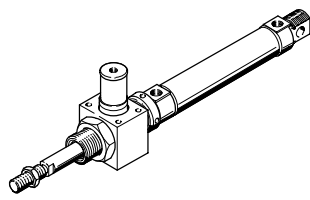

Standard cylinders DSNU/ESNU, ISO 6432

Peripherals overview

FESTO

Mounting attachments and accessories							
	DSNU/ ESNU	DSNU/ ESNU MA	DSNU			DSNU-Q	→Page
			MQ	MH	KP		
1	Rod eye SGS/CRSGS	■	■	■	■	■	1 / 1.1-49
2	Coupling piece KSG/KSZ	■	■	■	■	■	1 / 1.1-49
3	Rod clevis SG/CRSG	■	■	■	■	■	1 / 1.1-49
4	Self-aligning rod coupler FK	■	■	■	■	■	1 / 1.1-49
5	Flange mounting FBN/CRFBN	■	■	■	-	■	1 / 1.1-47
6	Foot mounting HBN/CRHBN	■	■	■	-	■	1 / 1.1-46
7	Swivel mounting WBN	■	■	■	-	■	1 / 1.1-48
8	Swivel mounting SBN	■	■	■	-	■	1 / 1.1-47
9	Clevis foot LBN/CRLBN	■	-	-	-	■	1 / 1.1-48
10	One-way flow control valve GRLA/GRLZ/CRGRLA	■	■	■	■	■	1 / 1.1-53
11	Push-in fitting QS	■	■	■	■	■	www.festo.com
12	Sensor mounting kit SMBR/CRSMBR	■	■	■	■	■	1 / 1.1-50
13	Proximity sensor SMEO/SMTO/CRSMEO-4	■	■	■	■	■	1 / 1.1-50
14	Sensor mounting kit SMBR-8	■	■	■	■	■	1 / 1.1-51
15	Proximity sensor SME/SMT-8	■	■	■	■	■	1 / 1.1-51
16	Sensor mounting kit SMBR-10	■	■	■	■	■	1 / 1.1-52
17	Proximity sensor SME/SMT-10	■	■	■	■	■	1 / 1.1-52
18	Guide unit FEN	■	■	■	-	-	1 / 1.1-49

Mounting options

Mounting front and rear

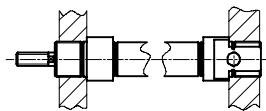

Mounting with hex nut

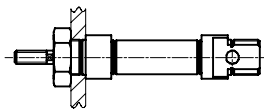

Swivel mounting

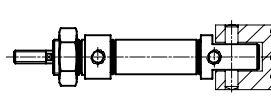

Installation options with mounting attachments

Foot mounting (for short strokes)

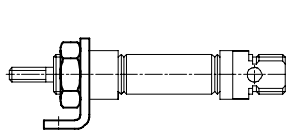

Foot mounting

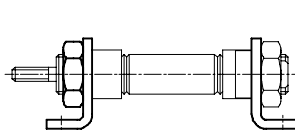

Flange mounting

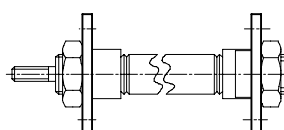

Swivel mounting

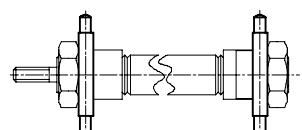

Standard cylinders DSNU/ESNU, ISO 6432

Type codes

FESTO

		DSNU	-	25	-	80	-	PPV	-	A	-	MQ
Type												
Double-acting												
DSNU	Standard cylinder											
Single-acting												
ESNU	Standard cylinder											
Piston Ø [mm]												
Stroke [mm]												
Cushioning												
P	Non-adjustable at either end											
PPV	Adjustable at both ends											
Position sensing												
A	Position sensing magnet											
Variant												
MQ	Lateral air connection											
MA	Axial air connection											
MH	With mounting flange on bearing cap											
CT	Free of copper, PTFE and silicone											

Modular product system

Individually configurable

DSNU → 1 / 1.1-26

ESNU → 1 / 1.1-34

- Square piston rod (protection against rotation)
- Through piston rod (piston rod type)
- Extended male piston rod thread
- Male piston rod thread, shortened at one end
- Female piston rod thread (female thread)
- Special piston rod thread (special thread)
- Extended piston rod at front
- Clamping unit on piston rod (clamping unit)
- Heat-resistant seals for temperatures up to 150 °C (temperature resistance)
- Slow speed (constant motion at low piston rod speeds)
- Low friction
- All external cylinder surfaces conform to corrosion resistance class CRC 3 (corrosion protection)

Standard cylinder DSNU, ISO 6432

FESTO

Technical data

Function

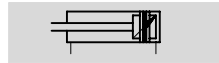
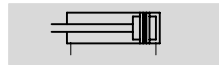

Additional variants

→ 1 / 1.1-15

⌀ - Diameter
8 ... 25 mm

┆ - Stroke length
1 ... 500 mm



Basic version

Lateral air connection MQ

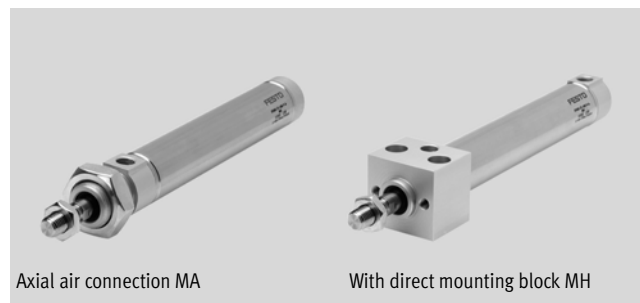

Axial air connection MA

With direct mounting block MH

General technical data						
Piston Ø	8	10	12	16	20	25
Pneumatic connection	M5	M5	M5	M5	G1/8	G1/8
Piston rod thread	M4	M4	M6	M6	M8	M10x1.25
Constructional design	Piston					
	Piston rod					
	Cylinder barrel					
Cushioning	Non-adjustable at either end					
	-			Adjustable at both ends		
Cushioning length (PPV) [mm]	-		9	12	15	17
Position sensing	Via proximity sensor					
Type of mounting	Direct mounting (MH variant only)					
	Via accessories					
Assembly position	Any					

Operating pressure [bar]						
Piston Ø	8	10	12	16	20	25
Operating medium	Filtered compressed air, lubricated or unlubricated					
Operating pressure	Basic version	1.5 ... 10	1 ... 10 ¹⁾			
	S10	-	-	1.5 ... 10		1 ... 10
	S11	-	-	0.45 ... 10	0.3 ... 10	

1) Piston Ø 12 PPV (cushioning adjustable at either end): 2...10 bar.

Ambient conditions						
Variant	Basic version	CT	S6	S10	S11	R3
Ambient temperature ¹⁾ [°C]	-20 ... +80		0 ... +150	+5 ... +80		-20 ... +80
Corrosion resistance class CRC ²⁾	2	2	2	2	2	3

1) Note operating range of proximity sensors

2) Corrosion resistance class 2 according to Festo standard 940 070

Components requiring moderate corrosion resistance. Externally visible parts with primarily decorative surface requirements which are in direct contact with a normal industrial environment or media such as coolants or lubricating agents.

Corrosion resistance class 3 according to Festo standard 940 070

Components requiring higher corrosion resistance. External visible parts in direct contact with industrial atmospheres or media such as solvents and cleaning agents, with a predominantly functional requirement for the surface.

Standard cylinder DSNU, ISO 6432

Technical data

Forces [N] and impact energy [J]						
Piston Ø [mm]	8	10	12	16	20	25
Theoretical force at 6 bar, advancing	30	47	68	121	189	295
Theoretical force at 6 bar, retracting	23	40	51	104	158	247
Max. impact energy at the end positions	0.03	0.05	0.07	0.15	0.20	0.30

Speed [mm/s]						
Piston Ø [mm]	16		20		25	
Speed with judder-free running, S10 horizontal, without load, at 6 bar	10 ... 100					
Minimum speed, advancing S11	2.7		5.3		<1 ¹⁾	
Minimum speed, retracting S11	3.2		4.7		<1 ¹⁾	

1) Measurements of less than 1 mm/s were not conducted.

Weights [g]						
Piston Ø [mm]	8	10	12	16	20	25
Product weight with 0 mm stroke	34.6	37.3	75	89.9	186.8	238
Additional weight per 10 mm stroke	2.4	2.7	4	4.6	7.2	11

Materials

Sectional view

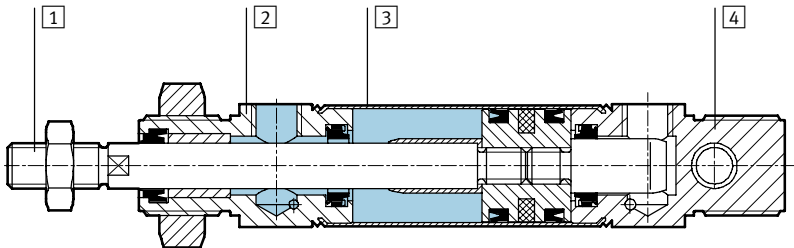

Variant	Basic version	R3	CT	S6	S10	S11
1 Piston rod	High-alloy stainless steel					
2 Bearing cap	Wrought aluminium alloy					
3 Cylinder barrel	High-alloy stainless steel					
4 End cap	Wrought aluminium alloy					
- Seals	Polyurethane, nitrile rubber			Fluoro rubber		
- Guide tape	-			Polyamide		

Standard cylinder DSNU, ISO 6432

Technical data

FESTO

Dimensions – Basic version

Download CAD data → www.festo.com/en/engineering

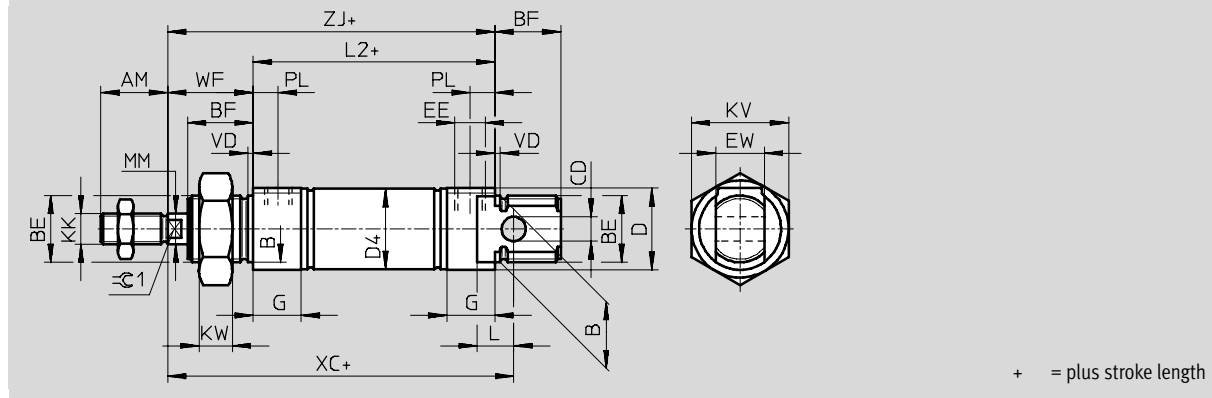

∅ [mm]	AM	B ∅ h9	BE	BF	CD ∅ E10	D ∅	D4 ∅	EE	EW	G	KK	KV
8	12	12	M12x1.25	12	4	15	9.3	M5	8	10	M4	19
10							11.3					
12	16	16	M16x1.5	17	6	20	13.3		12	M6	24	
16							17.3					
20	20	22	M22x1.5	20	8	27	21.3	G3/8	16	16	M8	32
25	22			22			22					

∅ [mm]	KW	L	L2	MM ∅	PL	T0	VD	WF	XC ±1	ZJ	∅C1
8	6	6	46	4	6	18	2	16	64	62	-
10			50	6		23		75	72	5	
12	8	9	56	8.2	31	22		82	78		
16			68			8		24	95	92	7
20	11	12	69.5	10	28	104	97.2	9			
25			28								

Standard cylinder DSNU, ISO 6432



Technical data

Dimensions – Variants

Download CAD data → www.festo.com/en/engineering

MQ – Lateral air connection

MA – Axial air connection

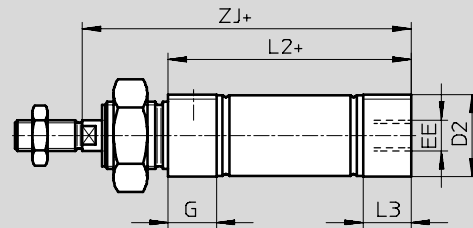
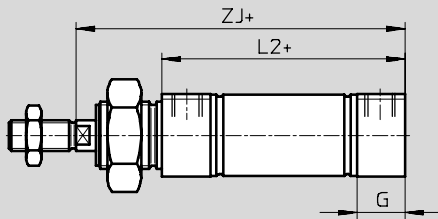

MH – With direct mounting block

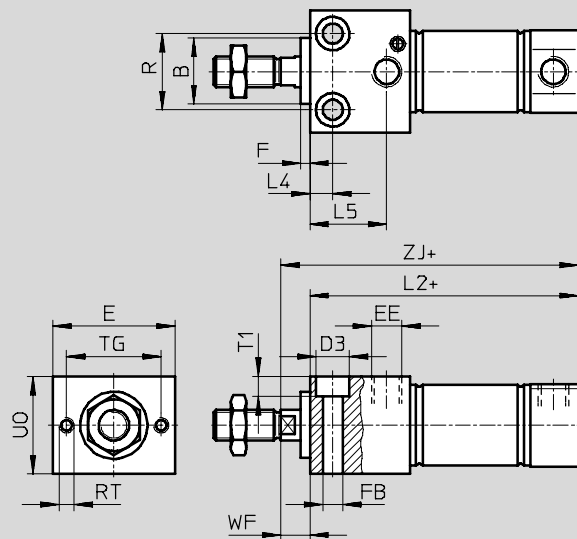

+ = plus stroke length

∅ [mm]	B ∅ h9	D2 ∅	D3 ∅	E	EE	F	FB ∅	G	L2					
										-MA	-MH			
8	12	10.5	6	24	M5	3	3.4	10	46	43.6	53.5			
10		12.5								43.1	53.8			
12	16	14.5	8	30					4.5	16	50	47.7	62	
16		17.5									56	53.7	67.5	
20	22	21.7	10	40					G $\frac{1}{8}$	5.5	16	68	66.5	81.5
25		26.7										11	6.6	69.5

∅ [mm]	L3	L4	L5	R	RT	TG	T1	U0	WF	ZJ		
											-MA	-MH
8	7.6	5	14	12	M3	18	3.4	16	8	62	59.6	61.5
10	7.1										59.1	61.8
12	7.7	6	18.1	16	M4	23	4.5	22	10	72	69.7	72
16										78	75.7	77.8
20	14.5	7.5	22.4	22	M5	31	5.5	28	11	92	90.5	91.5
25	14		25.2	25			6.6	32		97.5	96.5	97.2

Standard cylinder DSNU, ISO 6432

Technical data

Dimensions – Variants

Download CAD data → www.festo.com/en/engineering

S2 – Through piston rod

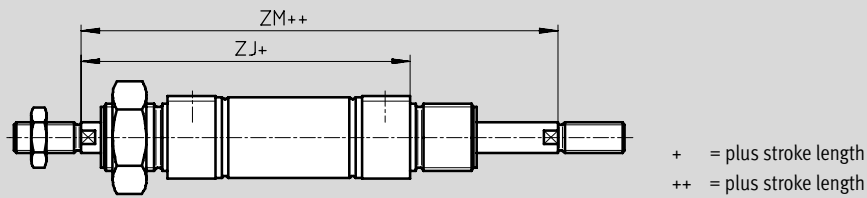

K2 – Extended male piston rod thread

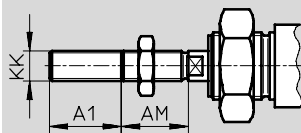

K6 – Shortened male piston rod thread

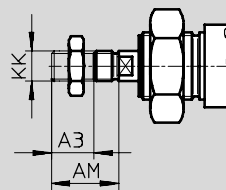

K3 – Female piston rod thread

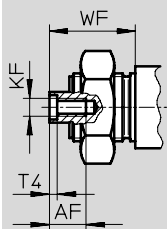

K5 – Special piston rod thread

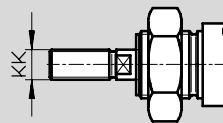

K8 – Extended piston rod

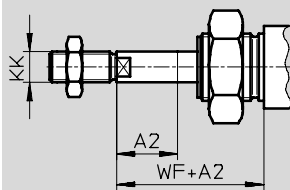

-  - Note

If variant K8 is required in combination with S2, the piston rod will only be extended on one side.

Ø [mm]	A1 max.	A2 max.	A3 max.	AM	AF	KF	KK		T4	WF	ZJ		ZM	
							Basic thread	Special thread ¹⁾			-MA	-MH		
8	15	50	4	12	-	-	M4	-	-	16	62	59.6	61.5	78.4
10					-	-		-	-			59.1	61.8	
12	20	100		16	-	-	M6	-	-	22	72	69.7	72	94
16					-	-		-	-		78	75.7	77.8	100
20			25	8	20	12	M4	M8	-	2	24	92	90.5	91.5
25	35	22	M6	M10x1.25	M10		2.6	28	97.5	96.5	97.2	125.5		

1) The special threads are only available as male threads. The scope of delivery does not include a hex nut for the piston rod thread.

Standard cylinder DSNU, ISO 6432

FESTO

Technical data

Ordering data – Basic version						
Type	Piston Ø [mm]	Stroke [mm]	Cushioning non-adjustable at either end		Adjustable cushioning at both ends	
			Part No.	Type	Part No.	Type
	8	10	19 177	DSNU-8-10-P-A	-	-
		25	19 178	DSNU-8-25-P-A		
		40	19 179	DSNU-8-40-P-A		
		50	19 180	DSNU-8-50-P-A		
		80	19 181	DSNU-8-80-P-A		
		100	19 182	DSNU-8-100-P-A		
	10	10	19 183	DSNU-10-10-P-A	-	-
		25	19 184	DSNU-10-25-P-A		
		40	19 185	DSNU-10-40-P-A		
		50	19 186	DSNU-10-50-P-A		
		80	19 187	DSNU-10-80-P-A		
		100	19 188	DSNU-10-100-P-A		
	12	10	19 189	DSNU-12-10-P-A	-	-
		25	19 190	DSNU-12-25-P-A		
		40	19 191	DSNU-12-40-P-A		
		50	19 192	DSNU-12-50-P-A		
		80	19 193	DSNU-12-80-P-A		
		100	19 194	DSNU-12-100-P-A		
		125	19 195	DSNU-12-125-P-A		
		160	19 196	DSNU-12-160-P-A		
	16	10	19 198	DSNU-16-10-P-A	-	-
		25	19 199	DSNU-16-25-P-A	33 973	DSNU-16-25-PPV-A
		40	19 200	DSNU-16-40-P-A	19 229	DSNU-16-40-PPV-A
		50	19 201	DSNU-16-50-P-A	19 230	DSNU-16-50-PPV-A
80		19 202	DSNU-16-80-P-A	19 231	DSNU-16-80-PPV-A	
100		19 203	DSNU-16-100-P-A	19 232	DSNU-16-100-PPV-A	
125		19 204	DSNU-16-125-P-A	19 233	DSNU-16-125-PPV-A	
160		19 205	DSNU-16-160-P-A	19 234	DSNU-16-160-PPV-A	
200		19 206	DSNU-16-200-P-A	19 235	DSNU-16-200-PPV-A	
20		10	19 207	DSNU-20-10-P-A	-	-
	25	19 208	DSNU-20-25-P-A	33 974	DSNU-20-25-PPV-A	
	40	19 209	DSNU-20-40-P-A	19 236	DSNU-20-40-PPV-A	
	50	19 210	DSNU-20-50-P-A	19 237	DSNU-20-50-PPV-A	
	80	19 211	DSNU-20-80-P-A	19 238	DSNU-20-80-PPV-A	
	100	19 212	DSNU-20-100-P-A	19 239	DSNU-20-100-PPV-A	
	125	19 213	DSNU-20-125-P-A	19 240	DSNU-20-125-PPV-A	
	160	19 214	DSNU-20-160-P-A	19 241	DSNU-20-160-PPV-A	
	200	19 215	DSNU-20-200-P-A	19 242	DSNU-20-200-PPV-A	
	250	19 216	DSNU-20-250-P-A	19 243	DSNU-20-250-PPV-A	
	300	19 217	DSNU-20-300-P-A	19 244	DSNU-20-300-PPV-A	
	320	34 718	DSNU-20-320-P-A	34 720	DSNU-20-320-PPV-A	

Standard cylinder DSNU, ISO 6432

FESTO



Technical data

Ordering data – Basic version						
Type	Piston Ø [mm]	Stroke [mm]	Cushioning non-adjustable at either end		Adjustable cushioning at both ends	
			Part No.	Type	Part No.	Type
	25	10	19 218	DSNU-25-10-P-A	–	–
		25	19 219	DSNU-25-25-P-A	33 975	DSNU-25-25-PPV-A
		40	19 220	DSNU-25-40-P-A	19 245	DSNU-25-40-PPV-A
		50	19 221	DSNU-25-50-P-A	19 246	DSNU-25-50-PPV-A
		80	19 222	DSNU-25-80-P-A	19 247	DSNU-25-80-PPV-A
		100	19 223	DSNU-25-100-P-A	19 248	DSNU-25-100-PPV-A
		125	19 224	DSNU-25-125-P-A	19 249	DSNU-25-125-PPV-A
		160	19 225	DSNU-25-160-P-A	19 250	DSNU-25-160-PPV-A
		200	19 226	DSNU-25-200-P-A	19 251	DSNU-25-200-PPV-A
		250	19 227	DSNU-25-250-P-A	19 252	DSNU-25-250-PPV-A
		300	19 228	DSNU-25-300-P-A	19 253	DSNU-25-300-PPV-A
		320	34 719	DSNU-25-320-P-A	34 721	DSNU-25-320-PPV-A
		400	35 191	DSNU-25-400-P-A	35 193	DSNU-25-400-PPV-A
		500	35 192	DSNU-25-500-P-A	35 194	DSNU-25-500-PPV-A

Standard cylinder DSNU, ISO 6432

FESTO

Technical data

Ordering data – Variants						
Type	Piston Ø [mm]	Stroke [mm]	Cushioning non-adjustable at either end		Adjustable cushioning at both ends	
			Part No.	Type	Part No.	Type
Variable stroke						
	8	10 ... 100	14 326	DSNU-8-...-P-A	-	-
	10	10 ... 100	14 325	DSNU-10-...-P-A		
	12	10 ... 200	14 324	DSNU-12-...-P-A		
	16	10 ... 200	14 323	DSNU-16-...-P-A	14 320	DSNU-16-...-PPV-A
	20	10 ... 320	14 328	DSNU-20-...-P-A	14 321	DSNU-20-...-PPV-A
	25	10 ... 500	14 327	DSNU-25-...-P-A	14 322	DSNU-25-...-PPV-A
Variable stroke, Free of copper, PTFE and silicone						
	8	10 ... 100	170 121	DSNU-8-...-P-A-CT	-	-
	10	10 ... 100	170 122	DSNU-10-...-P-A-CT		
	12	10 ... 200	170 123	DSNU-12-...-P-A-CT		
	16	10 ... 200	170 124	DSNU-16-...-P-A-CT	170 127	DSNU-16-...-PPV-A-CT
	20	10 ... 320	170 125	DSNU-20-...-P-A-CT	170 128	DSNU-20-...-PPV-A-CT
	25	10 ... 500	170 126	DSNU-25-...-P-A-CT	170 129	DSNU-25-...-PPV-A-CT

-  - Note

Further variants can be configured and ordered via the DSNU product modules → 1 / 1.1-26.

Standard cylinder DSNU-Q, non-rotating

FESTO

Technical data

Function

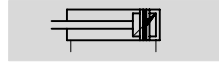
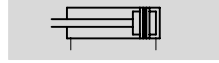

∅ - Diameter
12 ... 25 mm

l - Stroke length
1 ... 250 mm



General technical data				
Piston ∅	12	16	20	25
Pneumatic connection	M5	M5	G1/8	G1/8
Piston rod thread	M6	M6	M8	M10x1.25
Constructional design	Piston			
	Non-rotating with square piston rod			
Max. torque at the piston rod [Nm]	0.10	0.10	0.20	0.45
Cushioning	Non-adjustable at either end		-	
	Adjustable at both ends			
Cushioning length (PPV) [mm]	-	12	15	17
Position sensing	Via proximity sensor			
Type of mounting	Via accessories			
Assembly position	Any			

Operating pressure [bar]				
Piston ∅	12	16	20	25
Operating medium	Filtered compressed air, lubricated or unlubricated			
Operating pressure [bar]	1 ... 10 ¹⁾			

1) Piston ∅ 12 PPV (cushioning adjustable at either end): 2...10 bar.

Ambient conditions		
Variant	Basic version	R3
Ambient temperature ¹⁾ [°C]	-20 ... +80	
Corrosion resistance class CRC ²⁾	2	3

1) Note operating range of proximity sensors

2) Corrosion resistance class 2 according to Festo standard 940 070

Components requiring moderate corrosion resistance. Externally visible parts with primarily decorative surface requirements which are in direct contact with a normal industrial environment or media such as coolants or lubricating agents.

Corrosion resistance class 3 according to Festo standard 940 070

Components requiring higher corrosion resistance. External visible parts in direct contact with industrial atmospheres or media such as solvents and cleaning agents, with a predominantly functional requirement for the surface.

Standard cylinder DSNU-Q, non-rotating

FESTO

Technical data

Forces [N] and impact energy [J]				
Piston Ø [mm]	12	16	20	25
Theoretical force at 6 bar, advancing	68	121	189	295
Theoretical force at 6 bar, retracting	51	104	158	247
Max. impact energy at end positions	0.07	0.15	0.20	0.30

Weights [g]				
Piston Ø [mm]	12	16	20	25
Product weight with 0 mm stroke	80	110	215	275
Additional weight per 10 mm stroke	4.1	4.7	7.1	10.9

Materials

Sectional view

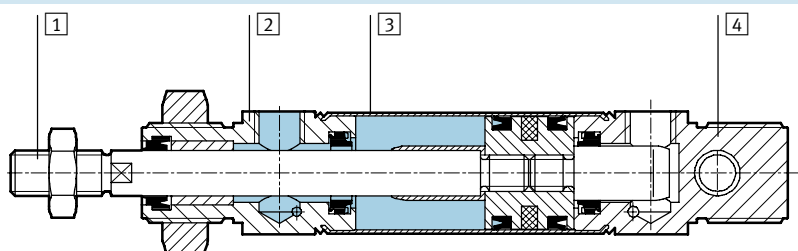

Variant	Basic version
1 Piston rod	High-alloy stainless steel
2 Bearing cap	Wrought aluminium alloy
3 Cylinder barrel	High-alloy stainless steel
4 End cap	Wrought aluminium alloy
- Seals	Polyurethane, nitrile rubber

Standard cylinder DSNU-Q, non-rotating

Technical data

FESTO

Dimensions

Download CAD data → www.festo.com/en/engineering

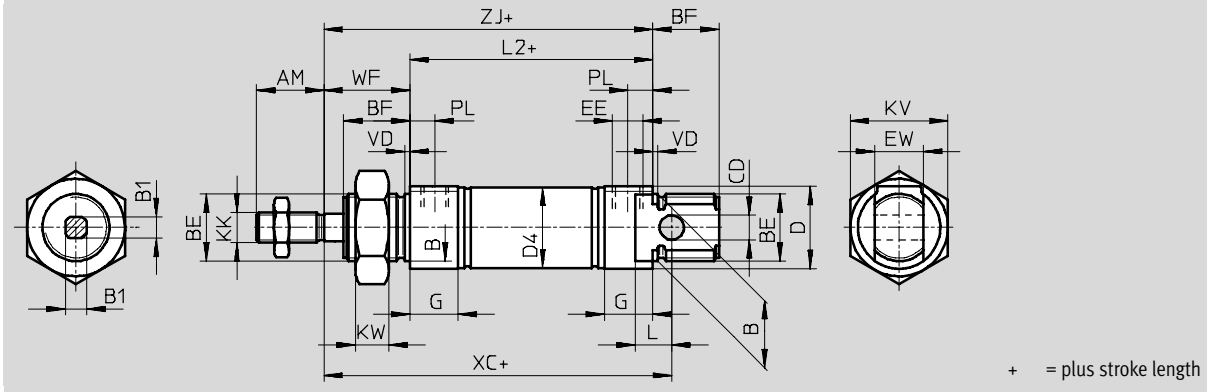

∅	AM	B ∅ h9	B1	BE	BF	CD ∅ E10	D ∅	D4 ∅	EE	EW
12	16	16	5.5	M16x1.5	17	6	20	13.3	M5	12
16								17.3		
20	22	22	7	M22x1.5	20	8	27	21.3	G1/8	16
25			9					22		

∅	G	KK	KV	KW	L	L2	PL	VD	WF	XC ±1	ZJ
12	10	M6	24	8	9	50	6	2	22	75	72
16						56				82	78
20	16	M8	32	11	12	68	24		95	92	
25		M10x1.25				69.5	8.2		28	104	97.5

Standard cylinder DSNU-...-KP, with clamping cartridge

FESTO

Technical data

Function

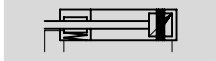
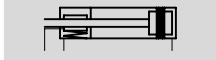

∅ - Diameter
8 ... 25 mm

l - Stroke length
1 ... 500 mm



General technical data						
Piston ∅	8	10	12	16	20	25
Pneumatic connection	M5	M5	M5	M5	G $\frac{1}{8}$	G $\frac{1}{8}$
Piston rod thread	M4	M4	M6	M6	M8	M10x1.25
Constructional design	Piston					
	Piston rod					
	Cylinder barrel					
Cushioning	Non-adjustable at either end					
	-			Adjustable at both ends		
Cushioning length (PPV) [mm]	-	-	9	12	15	17
Position sensing	Via proximity sensor					
Type of mounting	Via through-holes					
	Via accessories					
Assembly position	Any					
Clamping unit holding force [N]	80	80	180	180	350	350
Max. axial backlash at the clamped piston rod [mm]	0.25	0.25	0.25	0.25	0.3	0.3
Clamping unit pneumatic connection	M5	M5	M5	M5	M5	M5

Operating pressure [bar]						
Piston ∅	8	10	12	16	20	25
Operating medium	Filtered compressed air, lubricated or unlubricated					
Operating pressure [bar]	3 ... 10					

Ambient conditions		
Variant	Basic version	R3
Ambient temperature ¹⁾ [°C]	-10 ... +80	
Corrosion resistance class CRC ²⁾	2	3

1) Note operating range of proximity sensors

2) Corrosion resistance class 2 according to Festo standard 940 070

Components requiring moderate corrosion resistance. Externally visible parts with primarily decorative surface requirements which are in direct contact with a normal industrial environment or media such as coolants or lubricating agents.

Corrosion resistance class 3 according to Festo standard 940 070

Components requiring higher corrosion resistance. External visible parts in direct contact with industrial atmospheres or media such as solvents and cleaning agents, with a predominantly functional requirement for the surface.

Standard cylinder DSNU-...-KP, with clamping cartridge

Technical data

Forces [N] and impact energy [J]						
Piston Ø [mm]	8	10	12	16	20	25
Theoretical force at 6 bar, advancing	30	47	68	121	189	295
Theoretical force at 6 bar, retracting	23	40	51	104	158	247
Max. impact energy at the end positions ¹⁾	0.03	0.05	0.07	0.15	0.20	0.30

1) The values are reduced by approx. 50% at 80 °C

Materials

Sectional view

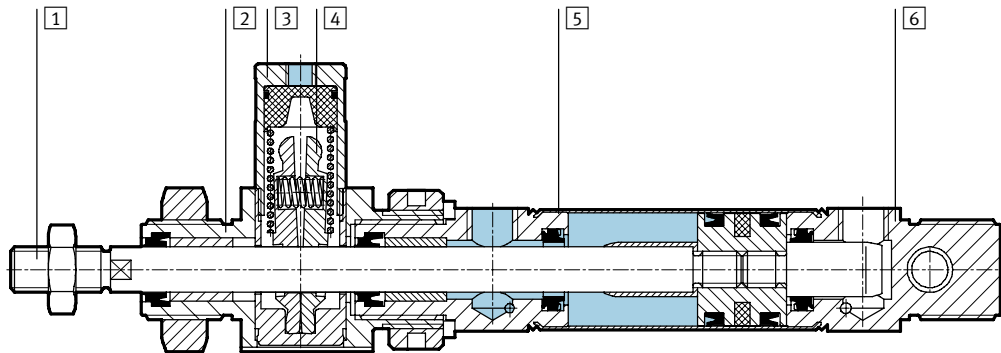

Variant	Basic version
1 Piston rod	High-alloy stainless steel
2 Bearing cap	Wrought aluminium alloy
3 Housing, clamping unit	Wrought aluminium alloy
4 Clamping jaws	Brass
5 Cylinder barrel	High-alloy stainless steel
6 End cap	Wrought aluminium alloy
- Clamping unit piston	Polyacetate
- Spring	Spring steel
- Seals	Polyurethane, nitrile rubber

Standard cylinder DSNU-...-KP, with clamping cartridge

Technical data

FESTO

Dimensions – Basic version

Download CAD data → www.festo.com/en/engineering

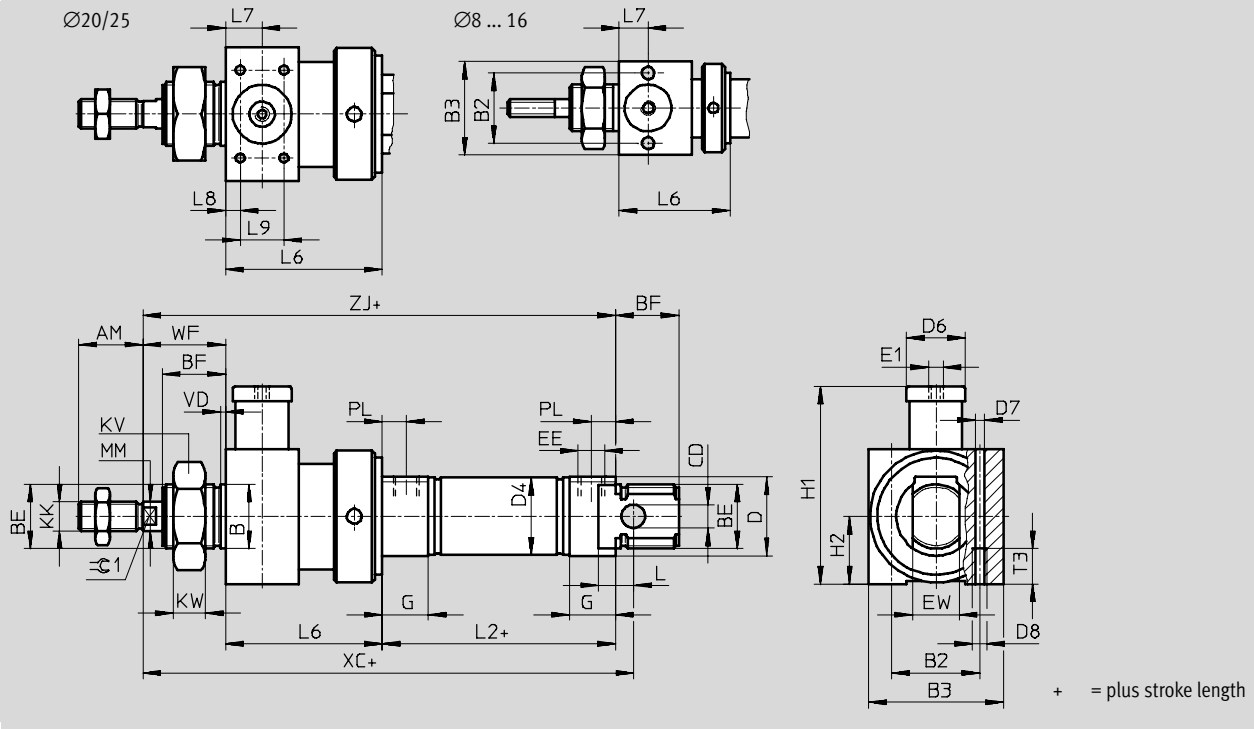

Dimensions – Variant

Download CAD data → www.festo.com/en/engineering

S2 – Through piston rod

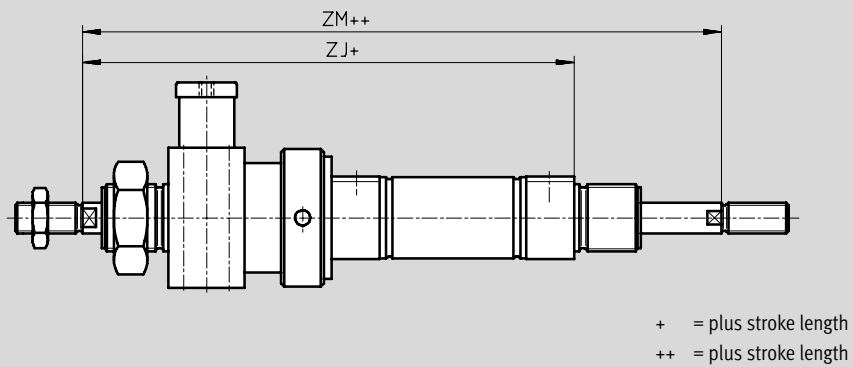

Standard cylinder DSNU-...-KP, with clamping cartridge

FESTO

Technical data

∅ [mm]	AM	B ∅ h9	B2	B3	BE	BF	CD ∅ E10	D ∅	D4 ∅	D6 ∅	D7 ∅	D8
8	12	12	19.5	27	M12x1.25	12	4	15	9.3	12	4.2	M5
10									11.3			
12	16	16	24	32	M16x1.5	17	6	20	13.3	16	4.2	M5
16									17.3			
20	20	22	27	36	M22x1.5	20	8	27	21.3	20	4.2	M5
25	22					22			26.5			

∅ [mm]	E1	EE	EW	G	H1	H2	KK	KV	KW	MM ∅	L	L2
8	M5	M5	8	10	34.5	13.5	M4	19	6	4	6	46
10			12		41	16	M6	24	8	6	9	50
12		G1/8	16	16	62.5	18	M8	32	11	8	12	68
16							M10x1.25			10		56
20							10			69.5		
25												

∅ [mm]	L6	L7	L8	L9	T3	PL	VD	WF	XC ±1	ZJ	ZM	≈C1
8	29 ±0.65	8	-	-	11	6	2	16	93	91	107	-
10			-	-				-	-			
12	38 ±0.75	10	-	-				22	113	110	132	5
16			-	-				24	120	116	138	
20	47 ±0.75	13	4.5	20	8.2	24	142	139	163	7		
25	48 ±0.75					28	152	145.5	173.5	9		

Standard cylinder DSNU, ISO 6432



Ordering data – Modular products

M Mandatory data					O Options			
Module No.	Function	Piston Ø	Stroke	Cushioning	Position sensing	Cylinder cap	Protection against torsion	Type of piston rod
193 986	DSNU	8	1 ... 500	P PPV	A	MQ MA MH	Q	S2
193 987		10						
193 988		12						
193 989		16						
193 990		20						
193 991		25						
Ordering example								
193 991	DSNU	- 25	- 350	- PPV	- A	- MH	-	- S2

Ordering table											
Size	8	10	12	16	20	25	Condi- tions	Code	Enter code		
M Module No.	193 986	193 987	193 988	193 989	193 990	193 991					
Function	Standard cylinder, double-acting, based on ISO 6432								DSNU	DSNU	
Piston Ø [mm]	8	10	12	16	20	25		-...			
Stroke [mm]	1 ... 100		1 ... 200		1 ... 320	1 ... 500		-...			
Cushioning	Flexible cushioning rings/plates at both ends								-P		
	-		-		Pneumatic cushioning adjustable at both ends		1	-PPV			
O Position sensing	Via proximity sensors							2	-A		
Cylinder cap	Lateral air connection, end cap							3	-MQ		
	Axial air connection, end cap							3	-MA		
	Mounting flange at front (direct mounting), bearing cap								-MH		
Protection against torsion	-		-		Square piston rod			-Q			
					5 ... 160	5 ... 160	5 ... 200		5 ... 250		
↓ Type of piston rod	Through piston rod								-S2		

1 PPV Not with cylinder end cap MA.
2 A Minimum stroke: 10 mm.

3 MQ, MA Not with piston rod type S2.

Transfer order code

Standard cylinder DSNU, ISO 6432



Ordering data – Modular products

Options									
Male thread extended	Male thread shortened	Female thread	Special thread	Piston rod extended at front	Clamping unit	Temperature-resistant	Constant motion (at low speed)	Running characteristics	Corrosion protection
...K2	...K6	K3	"..."K5	...K8	KP	S6	S10	S11	R3
-	7K6	-	"M10"K5	-	-	-	-	-	-

Ordering table										
Size	8	10	12	16	20	25	Conditions	Code	Enter code	
Male thread extended [mm]	Piston rod with extended male thread								...K2	
	1 ... 15	1 ... 20			1 ... 25	1 ... 35				
Male thread shortened [mm]	Piston rod with shortened male thread								...K6	
	1 ... 4				1 ... 8	1 ... 10				
Female thread	Female piston rod thread								-K3	
	-	-	-	-	(M4)	(M6)				
Special thread	Special piston rod thread								"..."K5	
	-	-	-	-	-	M10				
Piston rod extended at front [mm]	Extended piston rod at front								...K8	
	1 ... 50	1 ... 100								
Clamping unit	Clamping cartridge								-KP	
Temperature-resistant	Heat-resistant seals up to max. 150 °C			-	Heat-resistant seals up to max. 150 °C				-S6	
Constant motion (at low speed)	-	-	-	Slow speed (constant motion at low piston speeds)			4		-S10	
Running characteristics	-	-	-	Low friction			4		-S11	
Corrosion protection	-	-	High corrosion protection						-R3	

4 S10, S11 Not with cylinder cap MH, MA, MQ.

Transfer order code

- [] - [] - [] - [] - [] - [] - [] - [] - [] - []

Standard cylinder ESNU, ISO 6432

FESTO

Technical data

Function



Additional variants

→ 1 / 1.1-31

- \varnothing - Diameter
8 ... 25 mm

- | - Stroke length
1 ... 50 mm



Basic version



Axial air connection MA

General technical data						
Piston \varnothing [mm]	8	10	12	16	20	25
Pneumatic connection	M5	M5	M5	M5	G1/8	G1/8
Piston rod thread	M4	M4	M6	M6	M8	M10x1.25
Constructional design	Piston					
	Piston rod					
	Cylinder barrel					
Cushioning	Non-adjustable at either end					
Position sensing	Via proximity sensor					
Type of mounting	Via accessories					
Assembly position	Any					

Operating pressure [bar]						
Piston \varnothing	8	10	12	16	20	25
Operating medium	Filtered compressed air, lubricated or unlubricated					
Operating pressure [bar]	1.5 ... 10	1.2 ... 10				

Ambient conditions		
Variant	Basic version	CT
Ambient temperature ¹⁾ [°C]	-20 ... +80	
Corrosion resistance class CRC ²⁾	2	

1) Note operating range of proximity sensors

2) Corrosion resistance class 2 according to Festo standard 940 070

Components requiring moderate corrosion resistance. Externally visible parts with primarily decorative surface requirements which are in direct contact with a normal industrial environment or media such as coolants or lubricating agents.

Standard cylinder ESNU, ISO 6432

Technical data

Forces [N] and impact energy [J]						
Piston Ø [mm]	8	10	12	16	20	25
Theoretical force at 6 bar, advancing	24	41	61	107	169	270
Max. spring return force 10 mm stroke	4.9	4.9	6.3	13.2	18.3	22.9
Max. spring return force 25 mm stroke	4.1	4.1	5.4	11.9	16.5	21.2
Max. spring return force 50 mm stroke	2.8	4.8	3.9	9.8	13.6	18.5
Max. impact energy at the end positions ¹⁾	0.03	0.05	0.07	0.15	0.20	0.30

1) The values are reduced by approx. 50% at 80 °C

Weights ESNU-... [g]						
Piston Ø [mm]	8	10	12	16	20	25
Product weight with 0 mm stroke	35	37.3	75	89.9	186.8	238
Additional weight per 10 mm stroke	2.4	2.7	4	4.6	7.2	11

Weights ESNU-...-MA [g]						
Piston Ø [mm]	8	10	12	16	20	25
Product weight with 0 mm stroke	30	33	65	81	167	222
Additional weight per 10 mm stroke	2.4	2.7	4	4.6	7.2	11

Materials

Sectional view

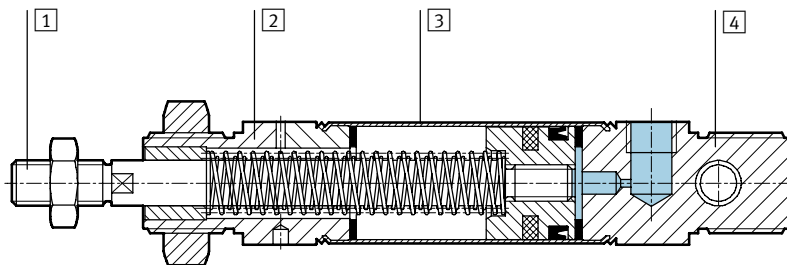

Variant	Basic version
1) Piston rod	High-alloy stainless steel
2) Bearing cap	Wrought aluminium alloy
3) Cylinder barrel	High-alloy stainless steel
4) End cap	Wrought aluminium alloy
- Seals	Polyurethane, nitrile rubber
- Spring	Spring steel

Standard cylinder ESNU, ISO 6432

Technical data

FESTO

Dimensions – Basic version

Download CAD data → www.festo.com/en/engineering

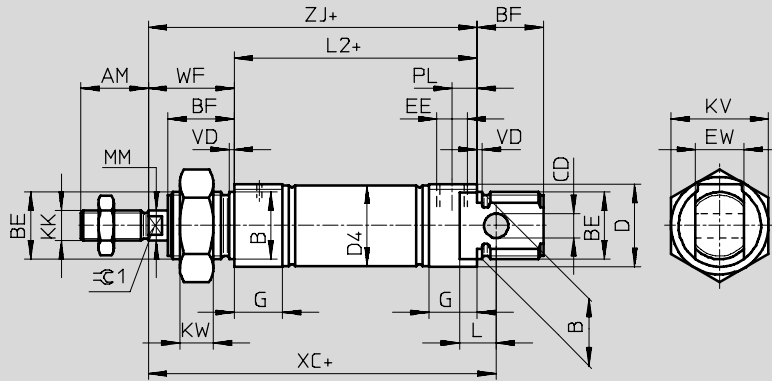

+ = plus stroke length

MA – Axial air connection

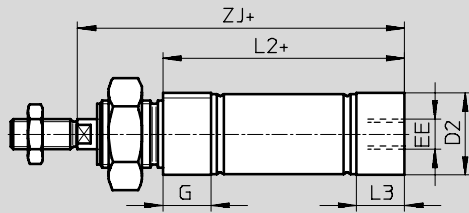

+ = plus stroke length

∅ [mm]	AM	B ∅ h9	BE	BF	CD ∅ E10	D ∅	D2 ∅	D4 ∅	EE	EW	G	KK	KV
8	12	12	M12x1.25	12	4	15	10.5	9.3	M5	8	10	M4	19
10							12.5	11.3					
12							14.5	13.3					
16	16	16	M16x1.5	17	6	20	17.5	17.3	G1/8	12	16	M6	24
20							21.7	21.3					
25	22	22	M22x1.5	22	8	27	26.7	26.5	G1/8	16	16	M8	32
												M10x1.25	

∅ [mm]	KW	L	L2	L3	MM ∅	PL	VD	WF	XC ±1	ZJ	∅C1		
			-MA							-MA			
8	6	6	46	43.6	7.6	4	6	2	16	64	62	59.6	-
10			50	43.1	7.1					75	72	59.1	
12	8	9	56	47.7	7.7	6	8.2	24	75	78	72	69.7	5
16			68	53.7	14.5					82	78	75.7	
20	11	12	69.5	66.5	14	10	28	104	95	92	90.5	7	
25			68.5	68.5	14					10	97.5	96.5	9

Standard cylinder ESNU, ISO 6432

Technical data

Dimensions – Variants

Download CAD data → www.festo.com/en/engineering

K2 – Extended male piston rod thread

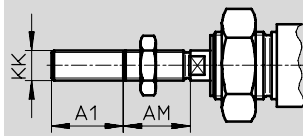

K6 – Shortened male piston rod thread

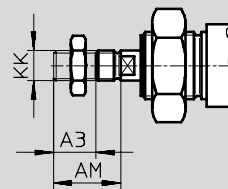

K3 – Female piston rod thread

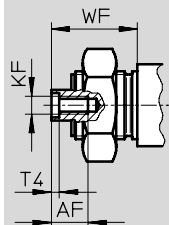

K5 – Special piston rod thread

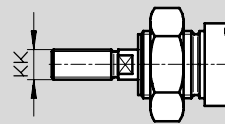

K8 – Extended piston rod

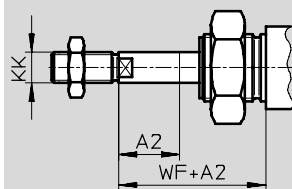

Ø [mm]	A1 max.	A2 max.	A3 max.	AF	AM	KF	KK		T4	WF
							Basic thread	Special thread ¹⁾		
8	15	50	4	–	12	–	M4	–	–	16
10				–		–		–		
12	20			–	16	–	M6	–	–	
16				–		–		–		
20	25		8	12	20	M4	M8	–	2	24
25	35		–	–	22	M6	M10x1.25	M10	2.6	28

1) The special threads are only available as male threads. The scope of delivery does not include a hex nut for the piston rod thread.

Standard cylinder ESNU, ISO 6432

FESTO



Technical data

Ordering data – Basic version						
Type	Stroke [mm]	Part No.	Type	Stroke [mm]	Part No. Type	
	Piston Ø 8 mm			Piston Ø 10 mm		
	10	19 254	ESNU-8-10-P-A	10	19 257	ESNU-10-10-P-A
	25	19 255	ESNU-8-25-P-A	25	19 258	ESNU-10-25-P-A
	50	19 256	ESNU-8-50-P-A	50	19 259	ESNU-10-50-P-A
	Piston Ø 12 mm			Piston Ø 16 mm		
	10	19 260	ESNU-12-10-P-A	10	19 263	ESNU-16-10-P-A
	25	19 261	ESNU-12-25-P-A	25	19 264	ESNU-16-25-P-A
	50	19 262	ESNU-12-50-P-A	50	19 265	ESNU-16-50-P-A
	Piston Ø 20 mm			Piston Ø 25 mm		
	10	19 266	ESNU-20-10-P-A	10	19 269	ESNU-25-10-P-A
	25	19 267	ESNU-20-25-P-A	25	19 270	ESNU-25-25-P-A
	50	19 268	ESNU-20-50-P-A	50	19 271	ESNU-25-50-P-A

Standard cylinder ESNU, ISO 6432

FESTO

Technical data

Ordering data – Variants				
Type	Piston Ø [mm]	Stroke [mm]	Part No.	Type
Variable stroke				
	8	1 ... 50	14 119	ESNU-8-...-P-A
	10	1 ... 50	14 118	ESNU-10-...-P-A
	12	1 ... 50	14 317	ESNU-12-...-P-A
	16	1 ... 50	14 316	ESNU-16-...-P-A
	20	1 ... 50	14 319	ESNU-20-...-P-A
	25	1 ... 50	14 318	ESNU-25-...-P-A
Free of copper, PTFE and silicone				
	8	1 ... 50	170 130	ESNU-8-...-P-A-CT
	10	1 ... 50	170 131	ESNU-10-...-P-A-CT
	12	1 ... 50	170 132	ESNU-12-...-P-A-CT
	16	1 ... 50	170 133	ESNU-16-...-P-A-CT
	20	1 ... 50	170 134	ESNU-20-...-P-A-CT
	25	1 ... 50	170 135	ESNU-25-...-P-A-CT

Standard cylinder ESNU, ISO 6432



Ordering data – Modular products

M Mandatory data					O Options →	
Module No.	Function	Piston Ø	Stroke	Cushioning	Position sensing	End cap
193 996	ESNU	8	1 ... 50	P	A	MA
193 997		10				
193 998		12				
193 999		16				
194 000		20				
194 001		25				
Ordering example						
194 002	ESNU	- 25	- 45	- P	- A	- MA

Ordering table										
Size	8	10	12	16	20	25	Condi- tions	Code		Enter code
M Module No.	193 996	193 997	193 998	193 999	194 000	194 001				
Function	Standard cylinder, single-acting pushing, based on ISO 6432							ESNU		ESNU
Piston Ø [mm]	8	10	12	16	20	25		-...		
Stroke [mm]	1 ... 50							-...		
Cushioning	Flexible cushioning rings/plates at both ends							-P		-P
O Position sensing	For proximity sensors						1	-A		
↓ End cap	Axial air connection							-MA		

1 A Minimum stroke: 10 mm.

Transfer order code

	ESNU	-		-		-	P	-		-	
--	-------------	---	--	---	--	---	----------	---	--	---	--

Standard cylinder ESNU, ISO 6432



Ordering data – Modular products

Options				
Male thread extended	Male thread shortened	Female thread	Special thread	Piston rod extended
...K2	...K6	K3	"..."K5	...K8
- 30K2	-	-	- "M10"K5	- 30K8

Ordering table										
Size	8	10	12	16	20	25	Condi- tions	Code	Enter code	
Male thread extended [mm]	Piston rod with extended male thread									
0	1 ... 15	1 ... 20		1 ... 25		1 ... 35	2	-...K2		
Male thread shortened [mm]	Piston rod with shortened male thread									
	1 ... 4		1 ... 8						-...K6	
Female thread	Female piston rod thread									
	-	-	-	-	(M4)	(M6)	3	-K3		
Special thread	Special piston rod thread									
	-	-	-	-	-	M10		-..."K5		
Piston rod extended [mm]	Piston rod extended									
	1 ... 50								...K8	

- 2 K2 Not with female thread K3, shortened male thread K6.
- 3 K3 Not with special thread K5, shortened male thread K6.

Transfer order code

- - - - -

Standard cylinders DSNU/ESNU, ISO 6432



Accessories

Foot mounting HBN/CRHBN

Scope of delivery:

HBN/CRHBN-...x1: 1 foot

HBN/CRHBN-...x2: 2 feet and 1 nut

Material:

HBN: Galvanised steel

CRHBN: High-alloy stainless steel

Free of copper, PTFE and silicone

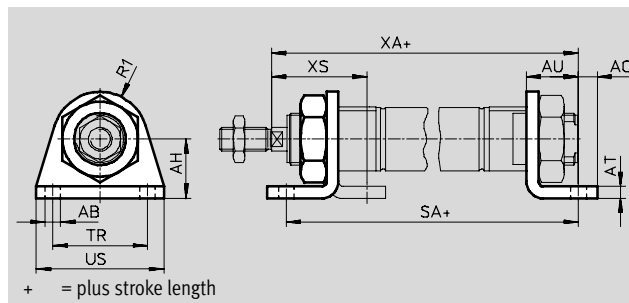

Dimensions and ordering data														
Ø [mm]	AB Ø	AH	AO	AT	AU	R1	SA		TR	US	XA		XS	
								-KP				-KP		
8, 10	4.5	16	5	3	11	10	68	97	25	35	73	102	24	-
12	5.5	20	6	4	14	13	78	116	32	42	86	124	32	-
16	5.5	20	6	4	14	13	84	122	32	42	92	130	32	-
20	6.6	25	8	5	17	20	102	149	40	54	109	156	36	-
25	6.6	25	8	5	17	20	103.5	151.5	40	54	114.5	162.5	40	-

Ø [mm]	Basic version				High corrosion protection			
	CRC ¹⁾	Weight [g]	Part No.	Type	CRC ¹⁾	Weight [g]	Part No.	Type
8, 10	2	20	5 123	HBN-8/10x1	-	-	-	-
	2	55	5 124	HBN-8/10x2	-	-	-	-
12, 16	2	40	5 125	HBN-12/16x1	4	40	161 866	CRHBN-12/16x1
	2	105	5 126	HBN-12/16x2	4	97	162 999	CRHBN-12/16x2
20, 25	2	90	5 127	HBN-20/25x1	4	55	161 867	CRHBN-20/25x1
	2	220	5 128	HBN-20/25x2	4	100	162 998	CRHBN-20/25x2

- 1) Corrosion resistance class 2 according to Festo standard 940 070
 Components requiring moderate corrosion resistance. Externally visible parts with primarily decorative surface requirements which are in direct contact with a normal industrial environment or media such as coolants or lubricating agents.
- Corrosion resistance class 4 according to Festo standard 940 070
 Components requiring higher corrosion resistance. Parts used with aggressive media, e.g. food or chemical industry. These applications should be supported with special tests with the media if required.

Standard cylinders DSNU/ESNU, ISO 6432



Accessories

Flange mounting FBN/CRFBN

Material:

FBN: Galvanised steel

CRFBN: High-alloy stainless steel

Free of copper, PTFE and silicone

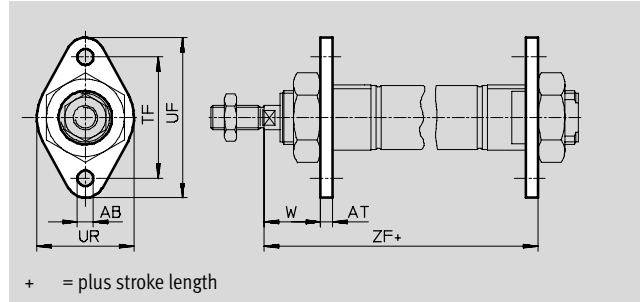
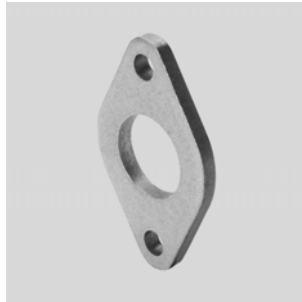

Dimensions and ordering data								
∅	AB	AT	TF	UF	UR	W	ZF	
[mm]	∅							-KP
8, 10	4.5	3	30	40	25	13	65	94
12	5.5	4	40	53	30	18	76	114
16	5.5	4	40	53	30	18	82	120
20	6.6	5	50	66	40	19	97	144
25	6.6	5	50	66	40	23	102.5	150.5

∅ [mm]	Basic version				High corrosion protection			
	CRC ¹⁾	Weight [g]	Part No.	Type	CRC ¹⁾	Weight [g]	Part No.	Type
8, 10	2	12	5 129	FBN-8/10	-	-	-	-
12, 16	2	25	5 130	FBN-12/16	4	25	161 864	CRFBN-12/16
20, 25	2	45	5 131	FBN-20/25	4	45	161 865	CRFBN-20/25

1) Corrosion resistance class 2 according to Festo standard 940 070

Components requiring moderate corrosion resistance. Externally visible parts with primarily decorative surface requirements which are in direct contact with a normal industrial environment or media such as coolants or lubricating agents.

Corrosion resistance class 4 according to Festo standard 940 070

Components requiring higher corrosion resistance. Parts used with aggressive media, e.g. food or chemical industry. These applications should be supported with special tests with the media if required.

Swivel mounting SBN

Material:

Mounting ring: Wrought aluminium alloy, anodised

Bearings: Bronze

Screws: Galvanised steel

Bracket: Steel

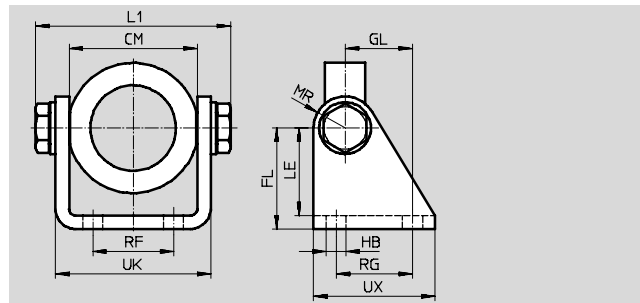
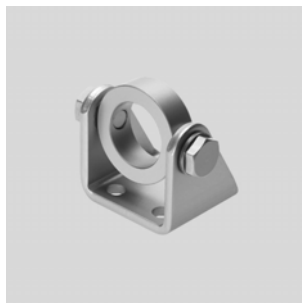

Dimensions and ordering data															
∅	CM	FL	GL	HB	L1	LE	MR	RF	RG	UK	UX	CRC ¹⁾	Weight	Part No.	Type
[mm]					max.								[g]		
20/25	38.1 ^{+0.4}	35	20	7	60.2	31	12	20	24	46.1	40	2	200	539 927	SBN-20/25

1) Corrosion resistance class 2 according to Festo standard 940 070

Components requiring moderate corrosion resistance. Externally visible parts with primarily decorative surface requirements which are in direct contact with a surrounding industrial atmosphere or media such as cooling or lubricating agents.

Standard cylinders DSNU/ESNU, ISO 6432

Accessories



Swivel mounting WBN

Material:
Galvanised steel
Free of copper, PTFE and silicone

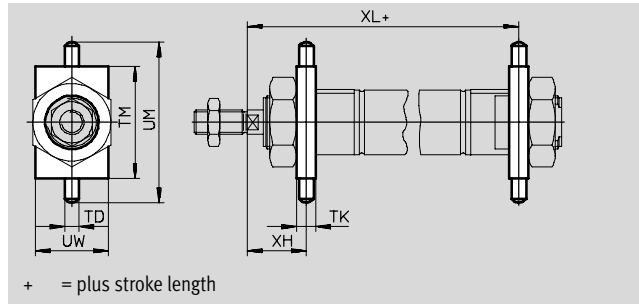

Dimensions and ordering data												
Ø [mm]	TD	TK	TM	UM	UW	XH	XL		CRC ¹⁾	Weight [g]	Part No.	Type
	Ø f8							-KP				
8, 10	4	6	26	38	20	13	65	94	2	20	8 608	WBN-8/10
12	6	8	38	58	25	18	76	114	2	50	8 609	WBN-12/16
16	6	8	38	58	25	18	82	120	2	50	8 609	WBN-12/16
20	6	8	46	66	30	20	96	143	2	70	8 610	WBN-20/25
25	6	8	46	66	30	24	101.5	149.5	2	70	8 610	WBN-20/25

1) Corrosion resistance class 2 according to Festo standard 940 070
Components requiring moderate corrosion resistance. Externally visible parts with primarily decorative surface requirements which are in direct contact with a surrounding industrial atmosphere or media such as cooling or lubricating agents.

Clevis foot LBN/CRLBN

Material:
LBN: Galvanised steel
CRLBN: High-alloy stainless steel
Free of copper, PTFE and silicone

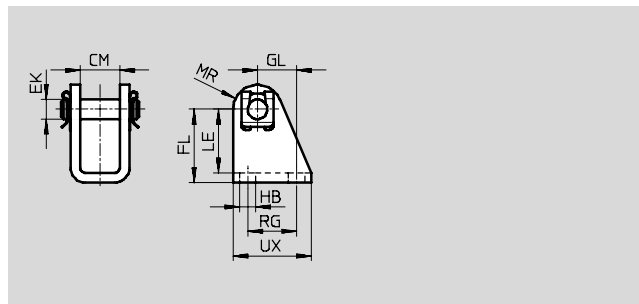

Dimensions and ordering data										
For Ø [mm]	CM	EK Ø	FL	GL	HB	LE	MR	RG	UX	
8, 10	8.1	4	24 +0.3/-0.2	13.8	4.5	21.5	5	12.5	20	
12, 16	12.1	6	27 +0.3/-0.2	13	5.5	24	7	15	25	
20, 25	16.1	8	30 +0.4/-0.2	16	6.6	26	10	20	32	

Ø [mm]	Basic version				High corrosion protection			
	CRC ¹⁾	Weight [g]	Part No.	Type	CRC ¹⁾	Weight [g]	Part No.	Type
8, 10	2	22	6 057	LBN-8/10	–	–	–	–
12, 16	2	40	6 058	LBN-12/16	4	55	161 862	CRLBN-12/16
20, 25	2	81	6 059	LBN-20/25	4	62	161 863	CRLBN-20/25





1) Corrosion resistance class 2 according to Festo standard 940 070
Components requiring moderate corrosion resistance. Externally visible parts with primarily decorative surface requirements which are in direct contact with a normal industrial environment or media such as coolants or lubricating agents.
Corrosion resistance class 4 according to Festo standard 940 070
Components requiring higher corrosion resistance. Parts used with aggressive media, e.g. food or chemical industry. These applications should be supported with special tests with the media if required.

Standard cylinders DSNU/ESNU, ISO 6432

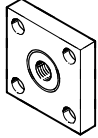
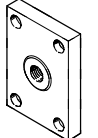

Accessories

FESTO

Ordering data – Piston rod attachments

Designation	For Ø	Part No.	Type	Designation	For Ø	Part No.	Type
Rod eye SGS				Rod clevis SG			
	8	9 253	SGS-M4		8	6 532	SG-M4
	10				10		
	12	9 254	SGS-M6		12	3 110	SG-M6
	16				16		
	20	9 255	SGS-M8		20	3 111	SG-M8
	25	9 261	SGS-M10x1,25		25	6 144	SG-M10x1,25
Coupling piece KSG				Coupling piece KSZ			
	8	-	-		12	36 123	KSZ-M6
	10				16		
	12				20	36 124	KSZ-M8
	16				25	36 125	KSZ-M10x1,25
	20						
	25	32 963	KSG-M10x1,25				
Self-aligning rod coupler FK							
	8	6 528	FK-M4				
	10						
	12	2 061	FK-M6				
	16						
	20	2 062	FK-M8				
	25	6 140	FK-M10x1,25				

Ordering data – Corrosion resistant piston rod attachments

Designation	For Ø	Part No.	Type	Designation	For Ø	Part No.	Type
Rod eye CRSGS				Rod clevis CRSG			
	12	195 580	CRSGS-M6		12	13 567	CRSG-M6
	16				16		
	20	195 581	CRSGS-M8		20	13 568	CRSG-M8
	25	195 582	CRSGS-M10x1,25		25	13 569	CRSG-M10x1,25

Ordering data – Guide units

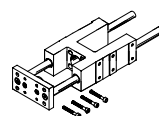
	For Ø [mm]	Stroke [mm]	with recirculating ball bearing guide		with plain bearing guide	
			Part No.	Type	Part No.	Type
	8, 10	1 ... 200	35 197	FEN-8/10-...-KF	35 196	FEN-8/10-...
	12, 16	1 ... 200	33 481	FEN-12/16-...-KF	19 168	FEN-12/16-...
	20	2 ... 250	33 482	FEN-20-...-KF	19 169	FEN-20-...
	25	2 ... 250	33 483	FEN-25-...-KF	19 170	FEN-25-...

Standard cylinders DSNU/ESNU, ISO 6432



Accessories

FESTO

Ordering data – Proximity sensors, u-shaped design, magneto-resistive								
	Mounting	Switch output	Electrical connection		Cable length [m]	Connection direction	Part No.	Type
			Cable	M8 plug				
NO contact								
	Via accessories	PNP	3-wire	–	2.5	In-line	152 836	SMT0-4U-PS-K-LED-24
			–	3-pin	–	In-line	152 742	SMT0-4U-PS-S-LED-24
		NPN	3-wire	–	2.5	In-line	152 837	SMT0-4U-NS-K-LED-24
			–	3-pin	–	In-line	152 743	SMT0-4U-NS-S-LED-24

Ordering data – Proximity sensors, u-shaped design, magnetic reed								
	Mounting	Electrical connection		Cable length [m]	Connection direction	Part No.	Type	
		Cable	M8 plug					
NO contact								
	Via accessories	3-wire	–	2.5	In-line	36 198	SME0-4U-K-LED-24	
			–	5	In-line	175 401	SME0-4U-K5-LED-24	
		–	3-pin	–	In-line	151 526	SME0-4U-S-LED-24-B	

Ordering data – Proximity sensors, round design, magnetic reed, corrosion resistant								
	Mounting	Electrical connection		Cable length [m]	Connection direction	Part No.	Type	
		Cable	M8 plug					
NO contact								
	Via accessories	3-wire	–	2.5	In-line	161 775	CRSMEO-4-K-LED-24	



Ordering data – Mounting kit for proximity sensor SME0/SMT0/CRSMEO								
Designation	For Ø	Part No.	Type	Designation	For Ø	Part No.	Type	
Mounting kit SMBR				Mounting kit CRSMBR, corrosion resistant				
	8	19 272	SMBR-8		8	–	–	
	10	19 273	SMBR-10		10	–	–	
	12	19 274	SMBR-12		12	164 581	CRSMBR-12	
	16	19 275	SMBR-16		16	164 582	CRSMBR-16	
	20	19 276	SMBR-20		20	164 583	CRSMBR-20	
	25	19 277	SMBR-25		25	164 584	CRSMBR-25	

Standard cylinders DSNU/ESNU, ISO 6432



Accessories

FESTO

Ordering data – Proximity sensor for slot type 8, magneto-resistive

	Mounting	Switch out-put	Electrical connection			Cable length [m]	Part No.	Type
			Cable	M8 plug	M12 plug			
NO contact								
	Via accessories	PNP	3-wire	–	–	2.5	525 898	SMT-8F-PS-24V-K2,5-OE
		NPN					525 909	SMT-8F-NS-24V-K2,5-OE
		–	2-wire	–	–	2.5	525 908	SMT-8F-ZS-24V-K2,5-OE
		PNP	–	3-pin	–	0.3	525 899	SMT-8F-PS-24V-K0,3-M8D
		NPN					525 910	SMT-8F-NS-24V-K0,3-M8D
PNP	–	–	3-pin	–	0.3	525 900	SMT-8F-PS-24V-K0,3-M12	
	Via accessories	PNP	3-wire	–	–	2.5	175 436	SMT-8-PS-K-LED-24-B
			–	3-pin	–	–	0.3	175 484
NC contact								
	Via accessories	PNP	3-wire	–	–	7.5	525 911	SMT-8F-PO-24V-K7,5-OE

Ordering data – Proximity sensor for slot type 8, magnetic reed

	Mounting	Electrical connection		Cable length [m]	Part No.	Type
		Cable	M8 plug			
NO contact						
	Via accessories	3-wire	–	2.5	525 895	SME-8F-DS-24V-K2,5-OE
		–	–	5.0	525 897	SME-8F-DS-24V-K5,0-OE
		2-wire	–	2.5	525 907	SME-8F-ZS-24V-K2,5-OE
	Via accessories	–	3-pin	0.3	525 896	SME-8F-DS-24V-K0,3-M8D
		3-wire	–	2.5	150 855	SME-8-K-LED-24
		–	3-pin	0.3	150 857	SME-8-S-LED-24
NC contact						
	Via accessories	3-wire	–	7.5	525 906	SME-8F-DO-24V-K7,5-OE



Ordering data – Mounting kit for proximity sensors SME/SMT-8



Designation	For Ø	Part No.	Type
Mounting kit SMBR-8			
	8	175 091	SMBR-8-8
	10	175 092	SMBR-8-10
	12	175 093	SMBR-8-12
	16	175 094	SMBR-8-16
	20	175 095	SMBR-8-20
	25	175 096	SMBR-8-25

Standard cylinders DSNU/ESNU, ISO 6432





Accessories

FESTO

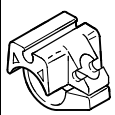
Ordering data – Proximity sensor for slot type 10, magneto-resistive								
	Mounting	Switch out-put	Electrical connection		Cable length [m]	Connection direction	Part No.	Type
			Cable	M8 plug				
NO contact								
	Via accessories	PNP	3-wire	–	2.5	In-line	525 915	SMT-10F-PS-24V-K2,5L-OE
			–	3-pin	0.3	In-line	525 916	SMT-10F-PS-24V-K0,3L-M8D
						Lateral	526 675	SMT-10F-PS-24V-K0,3Q-M8D
	Via accessories	PNP	–	3-pin	0.3	In-line	173 220	SMT-10-PS-SL-LED-24
			3-wire	–	2.5		173 218	SMT-10-PS-KL-LED-24

Ordering data – Proximity sensor for slot type 10, magnetic reed								
	Mounting	Electrical connection		Cable length [m]	Connection direction	Part No.	Type	
		Cable	M8 plug					
NO contact								
	Via accessories	–	3-pin	0.3	In-line	525 914	SME-10F-DS-24V-K0,3L-M8D	
		3-wire	–	2.5	In-line	525 913	SME-10F-DS-24V-K2,5L-OE	
		2-wire				526 672	SME-10F-ZS-24V-K2,5L-OE	
	Via accessories	3-wire	–	0.3	In-line	173 212	SME-10-SL-LED-24	
		–	3-pin	2.5		173 210	SME-10-KL-LED-24	



Ordering data – Mounting kit for proximity sensors SME/SMT-10								
Designation	For Ø						Part No.	Type
Mounting kit SMBR-10								
	8						175 101	SMBR-10-8
	10						173 227	SMBR-10-10
	12						175 102	SMBR-10-12
	16						173 228	SMBR-10-16
	20						175 103	SMBR-10-20
	25						175 104	SMBR-10-25

Ordering data – Plug sockets								
	Mounting	Switch output		Connection	Cable length [m]	Part No.	Type	
		PNP	NPN					
Straight plug socket								
	Union nut M8	■	■	3-pin	2.5	159 420	SIM-M8-3GD-2,5-PU	
					5	159 421	SIM-M8-3GD-5-PU	
	Union nut M12	■	■	3-pin	2.5	159 428	SIM-M12-3GD-2,5-PU	
					5	159 429	SIM-M12-3GD-5-PU	
Angled plug socket								
	Union nut M8	■	■	3-pin	2.5	159 422	SIM-M8-3WD-2,5-PU	
					5	159 423	SIM-M8-3WD-5-PU	
	Union nut M12	■	■	3-pin	2.5	159 430	SIM-M12-3WD-2,5-PU	
					5	159 431	SIM-M12-3WD-5-PU	

Standard cylinders DSNU/ESNU, ISO 6432

Accessories

FESTO

Ordering data – One-way flow control valves								
	Connection		Material	Part No.	Type			
	Thread	For tubing O.D.						
For exhaust air								
	M5	3	Metal design	193 137	GRLA-M5-QS-3-D			
		4		193 138	GRLA-M5-QS-4-D			
		6		193 139	GRLA-M5-QS-6-D			
	G1/8	3		193 142	GRLA-1/8-QS-3-D			
		4		193 143	GRLA-1/8-QS-4-D			
		6		193 144	GRLA-1/8-QS-6-D			
		8		193 145	GRLA-1/8-QS-8-D			
		For supply air						
				M5	3	Metal design	193 153	GRLZ-M5-QS-3-D
4	193 154		GRLZ-M5-QS-4-D					
6	193 155		GRLZ-M5-QS-6-D					
G1/8	3		193 156	GRLZ-1/8-QS-3-D				
	4		193 157	GRLZ-1/8-QS-4-D				
	6		193 158	GRLZ-1/8-QS-6-D				
	8		193 159	GRLZ-1/8-QS-8-D				

Ordering data – Corrosion resistant one-way flow control valves					
	Connection		Material	Part No.	Type
	Thread	For push-in fitting			
For exhaust air					
	M5	CRQS/CRQSL/CRQST	Electrolytically polished stainless steel casting	161 403	CRGRLA-M5-B
	G1/8			161 404	CRGRLA-1/8-B