

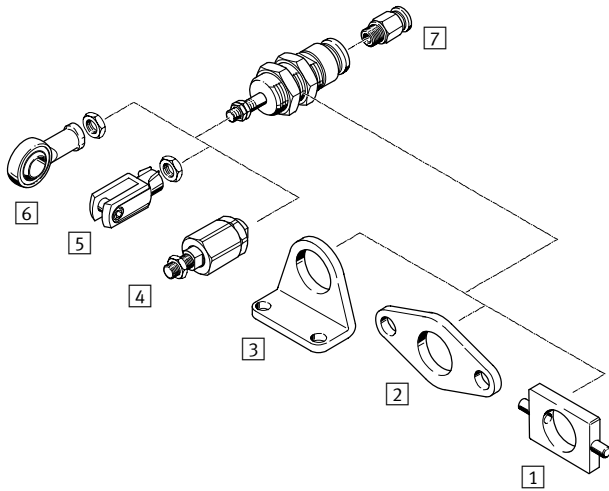

- Wide variety of applications for handling functions
- Minimal installation space required
- Stroke end positions can be varied according to the depth of engagement of the cylinder
- Additional mounting attachments

Cartridge cylinders EGZ

Peripherals overview and type codes



Installation without mounting attachments

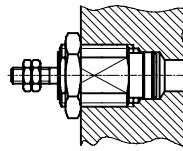

Minimal installation space required

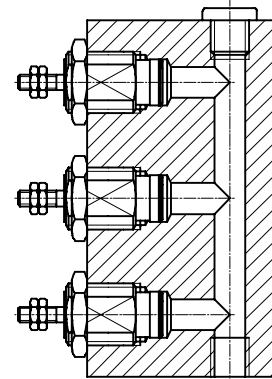

Mounting attachments and accessories					
	Brief description	Piston Ø 6 mm	Piston Ø 10 mm	Piston Ø 16 mm	→ Page
1	Swivel mounting WBN	-	■	■	1 / 2.5-6
2	Flange mounting FBN	-	■	■	1 / 2.5-5
3	Foot mounting HBN	-	■	■	1 / 2.5-5
4	Self-aligning rod coupler FK	-	■	■	1 / 2.5-6
5	Rod clevis SG	-	■	-	1 / 2.5-6
6	Rod eye SGS	-	■	-	1 / 2.5-6
7	Push-in fitting QS	■	■	■	Volume 3 www.festo.com

Cylinders with piston rods
Screw-in/screw-on cylinders

2.5

EGZ		-	16	-	10
Type					
Single acting, pushing					
EGZ	Cartridge cylinder				
Piston Ø [mm]					
Stroke [mm]					

Cartridge cylinders EGZ

Data sheet

Function

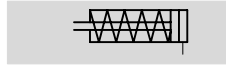

- \varnothing - Diameter
6 ... 16 mm
- | - Stroke length
5 ... 15 mm



Design			
Piston \varnothing	6	10	16
Pneumatic connection	M3	M5	M5
End of piston rod	Male thread	M3	M4
Operating medium	Filtered compressed air, lubricated or unlubricated		
Constructional design	Piston		
	Piston rod		
Cushioning	None		
Position sensing	None		
Type of mounting	With lock nut		
	With accessories		
Mounting position	Any		

Operating and environmental conditions			
Piston \varnothing	6	10	16
Operating pressure [bar]	1.5 ... 8		
Ambient temperature [°C]	-20 ... +80		

Forces and permitted applied load [N]									
Piston \varnothing	6			10			16		
Stroke	5	10	15	5	10	15	5	10	15
Theoretical force at 6 bar, advancing	14			42			109		
Spring return force	1.5	2.1	1.6	4	3.5	3	10	8.8	7.5
Maximum applied load at the piston rod	0.10			0.15			0.20		

Materials

Sectional view

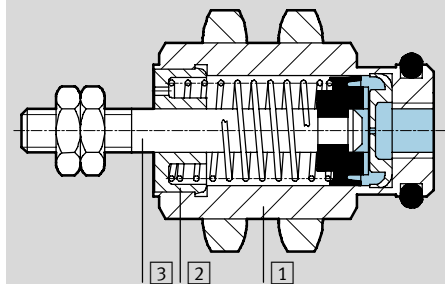

Cylinder	
1	Housing Brass, nickel-plated
2	Cover Polyacetal
3	Piston rod High-alloy steel

Cartridge cylinders EGZ

Data sheet



Dimensions

Download CAD data → www.festo.com/en/engineering

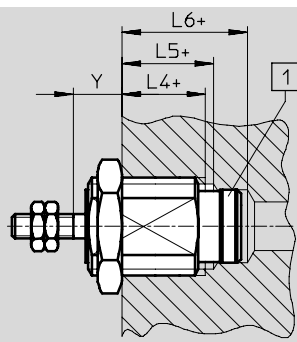
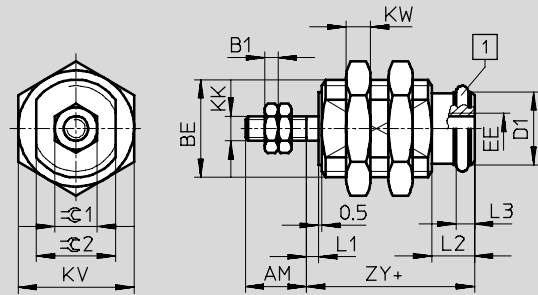

1 O-ring
+ = plus stroke length

∅	AM	B1	BE	D1 ∅ H7/f8	EE	KK	KV h13	KW	L1	L2	L3
6 ¹⁾	7	1.8	M10x1	7.6	M3	M3	13	3.5	1.5	6	2.4
6 ²⁾											
10	10	2.2	M16x1.5	12	M5	M4	19	4	2	7	3
16	12	2.7	M22x1.5	18.5	M5	M5	27	5	2	9	3.5

∅	L4 -Y +1	L5 -Y -1	L6 -Y +1	Y		ZY	≈C1 h13	≈C2 h13
				min.	max. + stroke			
6 ¹⁾	9	11	15.5	6	5	15	5.5	8
6 ²⁾	11	13	17.5	6	7	17		
10	11	13	18.5	7	6	17.5	7	13
16	13	16	21	8	6	20.5	8	19

- 1) 5 mm stroke
- 2) 10 and 15 mm stroke

Ordering data¹⁾

Stroke [mm]	Part No.	Type	Stroke [mm]	Part No.	Type
Piston ∅ 6 mm			Piston ∅ 10 mm		
5	15 033	EGZ-6-5	5	15 036	EGZ-10-5
10	15 034	EGZ-6-10	10	15 037	EGZ-10-10
15	15 035	EGZ-6-15	15	15 038	EGZ-10-15
Piston ∅ 16 mm					
5	15 039	EGZ-16-5			
10	15 040	EGZ-16-10			
15	15 041	EGZ-16-15			

1) Two hex nuts each for the male cylinder thread and for the piston thread are included in the scope of delivery.

Cartridge cylinders EGZ

Accessories

Foot mounting HBN for piston Ø 10, 16 mm

Material:
Steel
Free of copper, PTFE and silicone

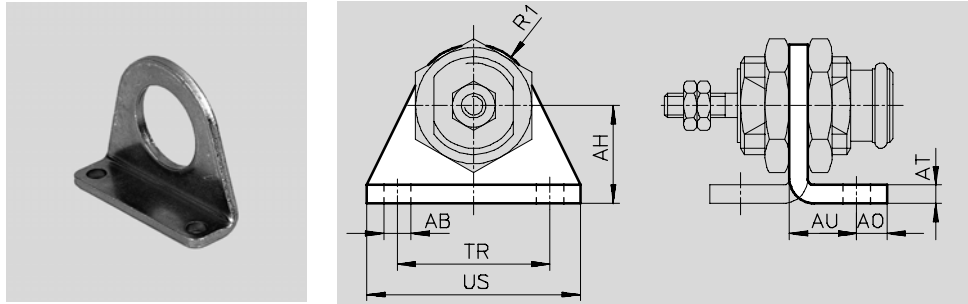

Dimensions and ordering data													
For Ø	Minimum stroke lengths	AB Ø	AH	AO	AT	AU	R1	TR	US	CRC ¹⁾	Weight [g]	Part No.	Type
10	5	5.5	20	6	4	14	13	32	42	2	40	5 125	HBN-12/16X1
16	7	6.6	25	8	5	17	20	40	54	2	90	5 127	HBN-20/25X1

1) Corrosion resistance class 2 according to Festo standard 940 070
Components requiring moderate corrosion resistance. Externally visible parts with primarily decorative surface requirements which are in direct contact with a surrounding industrial atmosphere or media such as cooling or lubricating agents.

Flange mounting FBN for piston Ø 10, 16 mm

Material:
Steel
Free of copper, PTFE and silicone

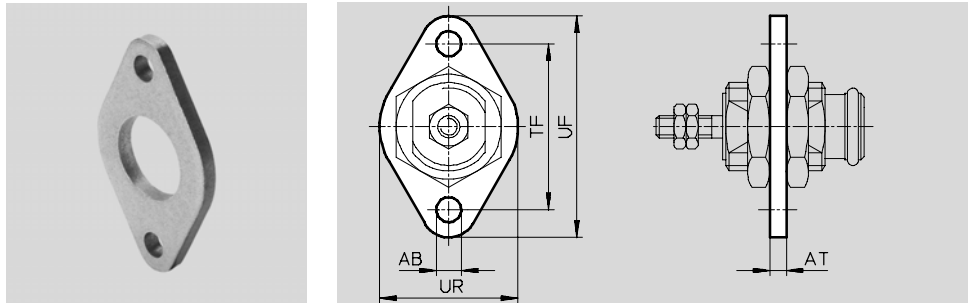

Dimensions and ordering data												
For Ø	Minimum stroke lengths	AB Ø	AT	TF	UF	UR	CRC ¹⁾	Weight [g]	Part No.	Type		
10	5	5.5	4	40	53	30	2	25	5 130	FBN-12/16		
16	7	6.6	5	50	68	40	2	45	5 131	FBN-20/25		

1) Corrosion resistance class 2 according to Festo standard 940 070
Components requiring moderate corrosion resistance. Externally visible parts with primarily decorative surface requirements which are in direct contact with a surrounding industrial atmosphere or media such as cooling or lubricating agents.

Cylinders with piston rods
Screw-in/screw-on cylinders
2.5

Cartridge cylinders EGZ

Accessories



Swivel mounting WBN for piston \varnothing 10, 16 mm

Material:
Tempered steel

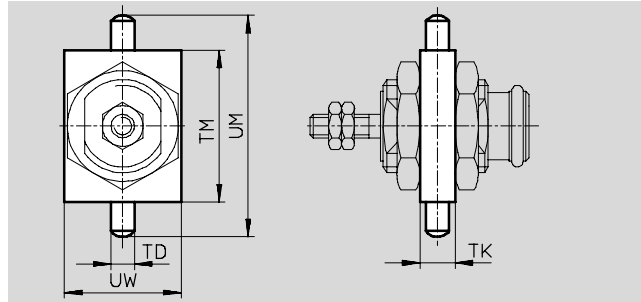

Dimensions and ordering data									
For \varnothing	Minimum stroke lengths	TD \varnothing m6	TK	TM	UM	UW	Weight [g]	Part No.	Type
10	9	6	8	38	58	25	50	8 609	WBN-12/16
16	10	6	8	46	66	30	70	8 610	WBN-20/25

Ordering data – Piston rod attachments				Ordering data – Piston rod attachments				Technical data → NO TAG	
Ordering data – Piston rod attachments				Ordering data – Piston rod attachments				Technical data → www.festo.com	
Designation	For \varnothing	Part No.	Type	Designation	For \varnothing	Part No.	Type		
Rod eye SGS				Rod clevis SG					
	10	9 253	SGS-M4		10	6 532	SG-M4		
Self-aligning rod coupler FK									
	10	6 528	FK-M4						
	16	30 984	FK-M5						

Cylinders with piston rods
Screw-in/screw-on cylinders

2.5

Core Range