

 **New**
HGP-20

Standard grippers

FESTO

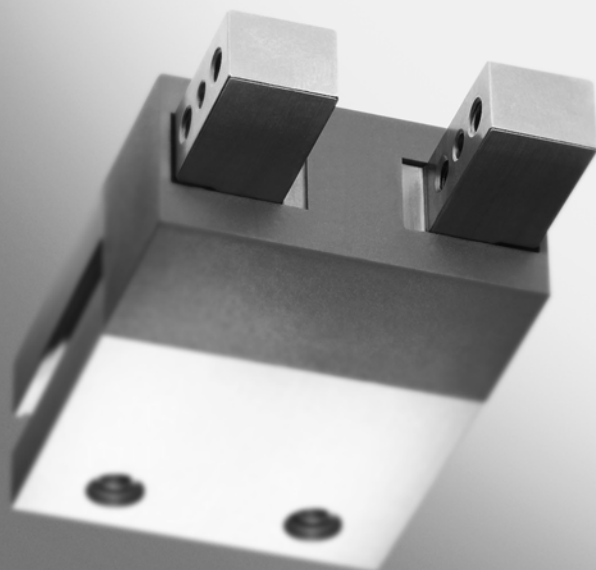

- **Economical and versatile**
- **Self-centring**
- **Choice of gripping action**

Handling units
Standard grippers

7.5

Standard grippers

Key features

FESTO

7.5
Handling units
Standard grippers

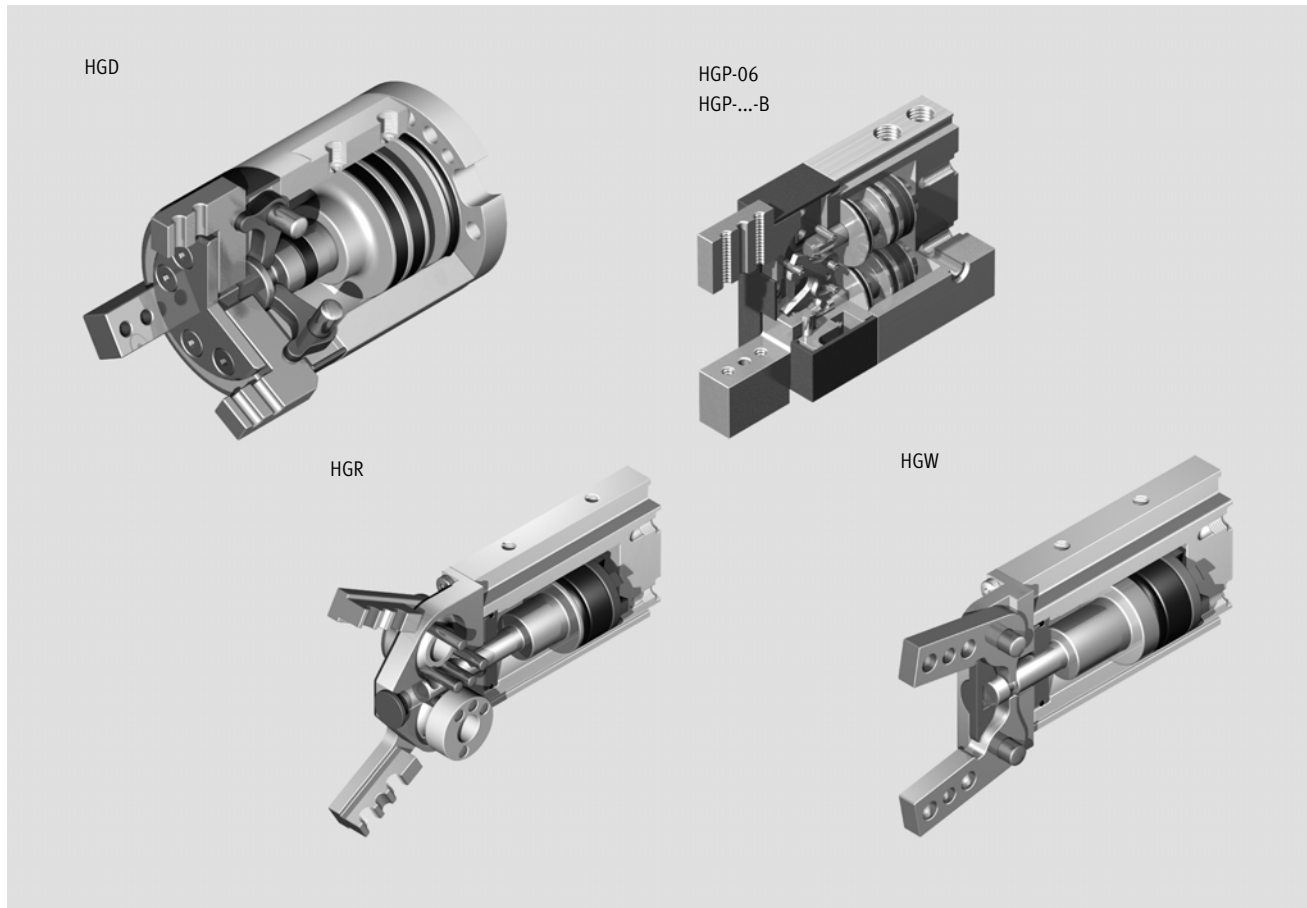

System product for handling and assembly technology

- Double-acting piston drive
- Self-centring
- Optional gripping action:
 - External/internal gripping
- Sensor technology:
 - Adaptable proximity sensors on the small standard grippers
 - Integral proximity sensors for medium and large standard grippers
- Versatile thanks to externally adaptable gripper fingers
- Wide range of options for mounting on drive units



Gripper selection software
www.festo.com/en/engineering

Parallel grippers HGP

→ 1 / 7.5-8

- High gripping force and compact size
- Max. repetition accuracy
- Gripping force retention
- Internal fixed flow control
- With protective dust cap for use in dusty environments (protection class IP54)

Three-point grippers HGD

→ 1 / 7.5-19

- Maximum precision
- High holding force

Radial grippers HGR

→ 1 / 7.5-25

- Constant gripping force over the entire angle range
- 180° opening angle
- Internal fixed flow control

Angle grippers HGW

→ 1 / 7.5-32

- Constant gripping force over the entire angle range
- 40° opening angle
- Internal fixed flow control

Standard grippers

Key features



Mounting options for external gripper fingers (customer-specific)

Parallel grippers
HGP-06/-10/-16/-20/-25/-35

Three-point grippers
HGD-16/-32/-50

Radial grippers
HGR-10/-16/-25/-32/-40

Angle grippers
HGW-10/-16/-25/-32/-40

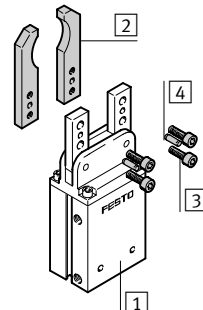
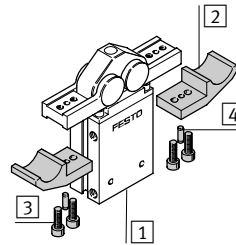
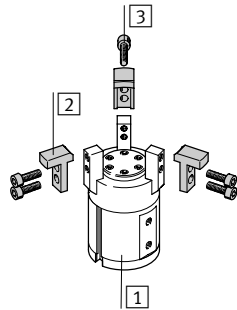
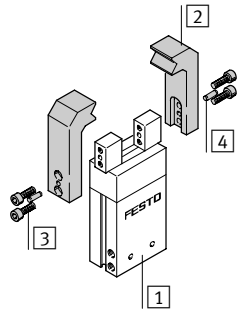

- 1 Standard gripper
- 2 External gripper fingers
- 3 Mounting screws
- 4 Dowel pins

Parallel grippers HGP

HGP-16/-25...-SSK

New
Protective dust cap

The sizes 16 and 25 can be adapted for use in dusty environments. They fulfil the requirements for protection class IP54.

The technical data corresponds to the data for parallel gripper HGP without protective dust cap.



Note

Standard grippers should always be used with exhaust air flow control. They are not designed for the following or similar applications:

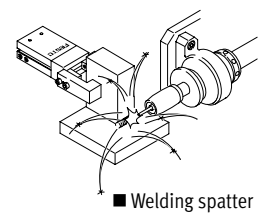
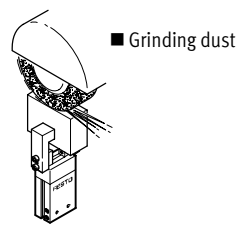
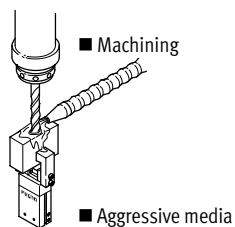

Standard grippers

Key features

FESTO

Adaptable and integratable sensors

→ 1 / 7.5-39

Parallel gripper HGP-06

Three-point gripper HGD-16

Radial gripper HGR-10

Angle gripper HGW-10

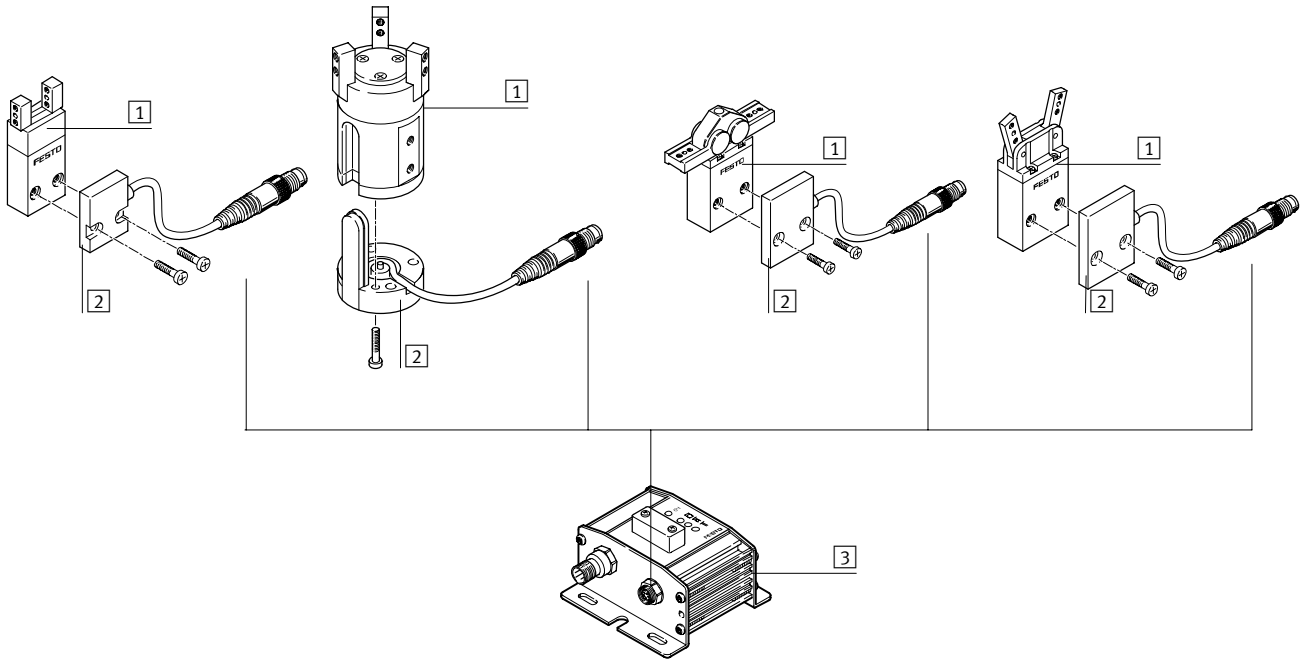

- 1 Standard gripper
- 2 Proximity sensor SMH-S1
- 3 Evaluation unit SMH-AE1 for proximity sensor SMH-S1

HGP-10/-16/-20/-25/-35

HGD-32/-50

HGR-16/-25/-32/-40

HGW-16/-25/-32/-40

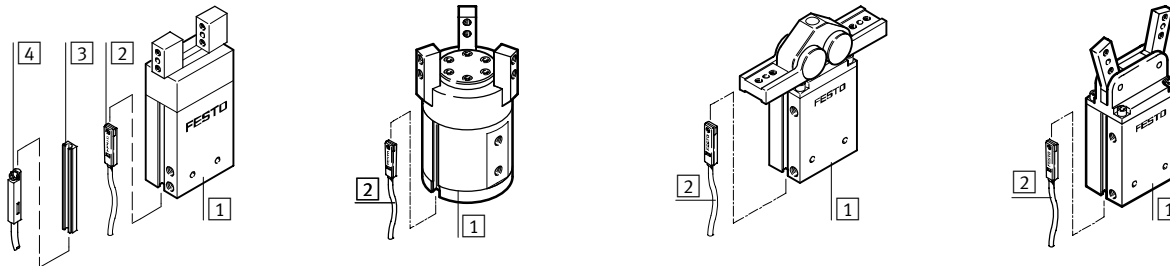

- 1 Standard gripper
- 2 Proximity sensor SME-8/SMT-8
- 3 Sensor strip HGP-SL, can be glued into place
- 4 Proximity sensor SME-10/SMT-10

Standard grippers

System example

System product for handling and assembly technology

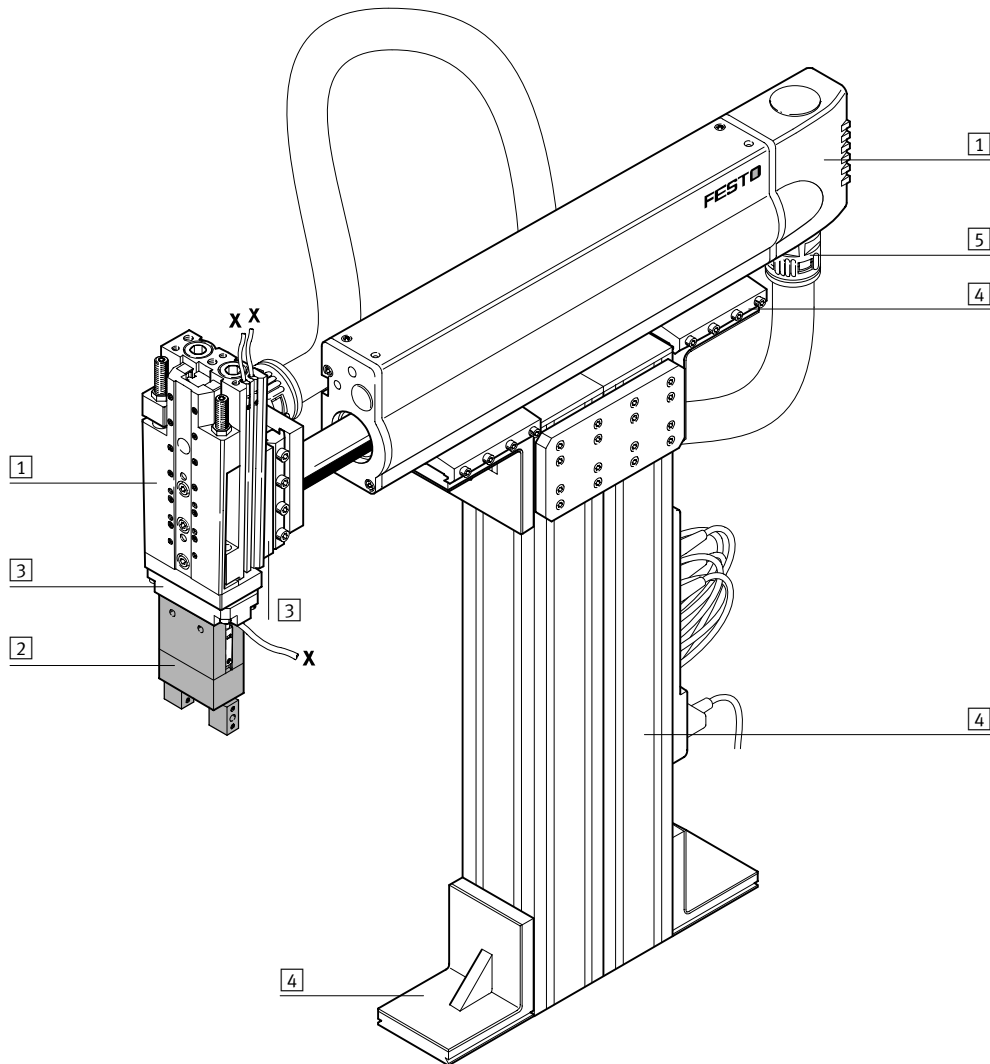

System elements and accessories		
	Brief description	→ Page
1	Drive units	Wide range of combinations options within handling and assembly technology Volume 1 www.festo.com Volume 1
2	Grippers	Wide range of variation options within handling and assembly technology Volume 1 www.festo.com Volume 2
3	Adapters	For drive/drive and drive/gripper connections Volume 5 www.festo.com Volume 2
4	Basic components	Profiles and profile connections as well as profile/drive connections Volume 5 www.festo.com Volume 1
5	Installation components	For achieving a clear-cut, safe layout of electrical cables and tubing Volume 5 www.festo.com Volume 1

- Axes	Wide range of combinations options within handling and assembly technology	Volume 5 www.festo.com Volume 1
- Motors	Servo and stepper motors, with or without gearing	Volume 5 www.festo.com Volume 1

Standard grippers

Type codes

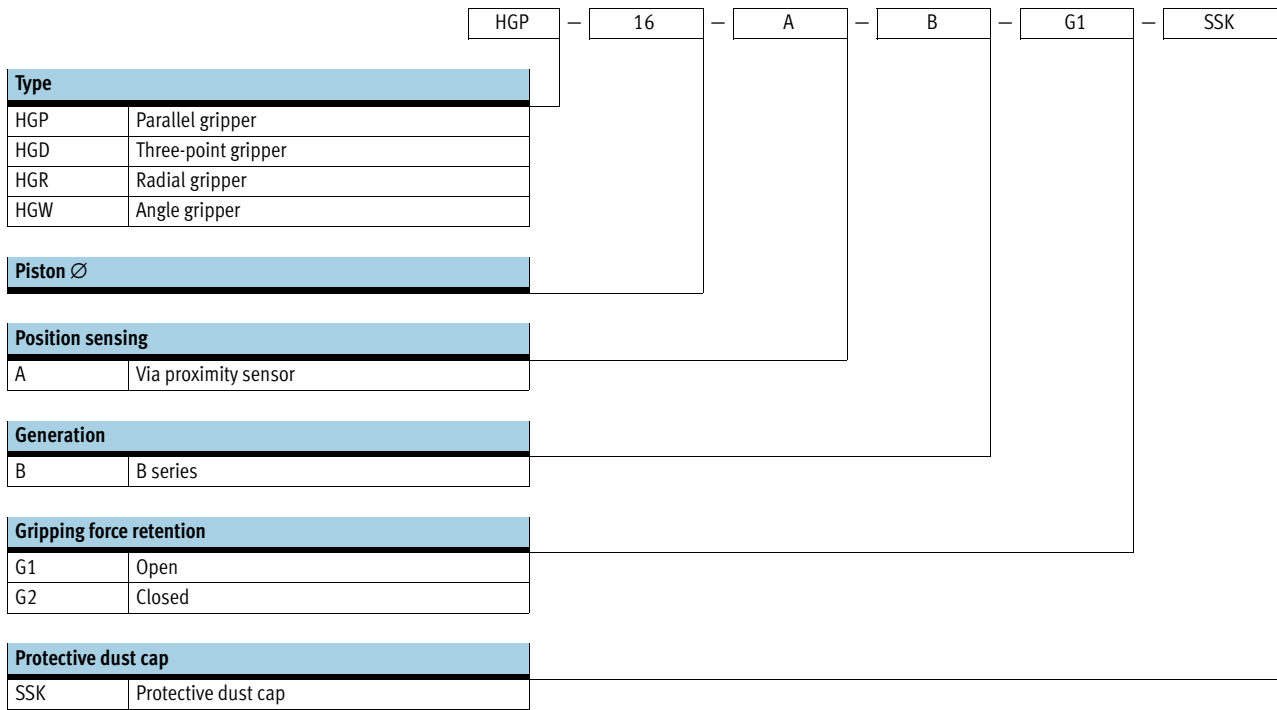

Parallel grippers HGP

Technical data

FESTO

Function

Double-acting

HGP-06-A, HGP-...-A-B

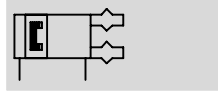

-  - Piston Ø
6 ... 35 mm

-  - Stroke
4 ... 25 mm

Variants

■ with gripping force retention ...

... open HGP-...-G1

... closed HGP-...-G2

■ with protective dust cap

-  - www.festo.com/en/Spare_parts_service
Wearing parts kits
→ 1 / 7.5-17

-  - Repair service

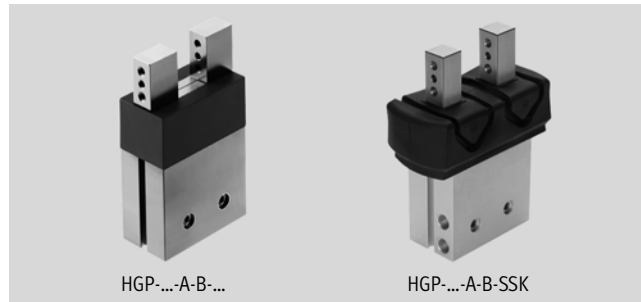

General technical data							
Piston Ø	6	10	16	20	25	35	
Design	Wedge mechanism		Lever				
Mode of operation	Double-acting						
Gripper function	Parallel						
Number of gripper jaws	2						
Max. applied load per external gripper finger ¹⁾	[N]	0.1	0.2	0.4	0.6	0.8	1.2
Stroke	[mm]	2	3	5	6.5	7.5	12.5
Pneumatic connection	M3			M5		G $\frac{1}{8}$	
Repetition accuracy ²⁾	[mm]	≤ 0.04					
Max. interchangeability	[mm]	0.2					
Max. operating frequency	[Hz]	4					
Position sensing	Via proximity sensor						
Type of mounting	Via female thread and centring hole						
	-	Via through-holes					

1) Valid for unthrottled operation.

2) End-position drift under constant conditions of use with 100 consecutive strokes in the direction of movement of the gripper jaws.

Operating and environmental conditions							
Piston Ø	6	10	16	20	25	35	
Min. operating pressure	HGP-...-A/-B [bar]	2					
	HGP-...-G... [bar]	5					
Max. operating pressure	[bar]	8					
Operating medium	Filtered compressed air, lubricated or unlubricated						
Ambient temperature	[°C]	+5 ... +60					
Corrosion resistance class CRC ¹⁾		2	1				

1) Corrosion resistance class 1 according to Festo standard 940 070

Components requiring low corrosion resistance. Transport and storage protection. Parts that do not have primarily decorative surface requirements, e.g. in internal areas that are not visible or behind covers.

Corrosion resistance class 2 according to Festo standard 940 070

Components requiring moderate corrosion resistance. Externally visible parts with primarily decorative surface requirements which are in direct contact with a normal industrial environment or media such as coolants or lubricating agents.

Weight [g]							
Piston Ø	6	10	16	20	25	35	
HGP-...-A	18	75	194	396	725	1 369	
HGP-...-G1	-	76	197	402	737	1 387	
HGP-...-G2	-	76	197	402	737	1 387	
With protective dust cap							
HGP-...-SSK	-	-	197	-	737	-	

Parallel grippers HGP

Technical data

Materials

Sectional view

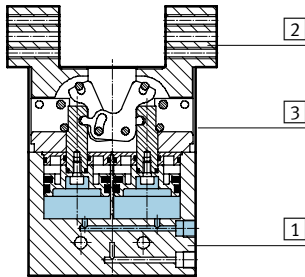

Piston Ø	6	10	16	20	25	35
1 Housing	Nickel-plated aluminium	Hard anodized aluminium				
2 Gripper jaw	Nickel-plated steel	High-alloy steel				
3 Cover cap	Polyamide					
- Protective dust cap SSK	-		Thermoplastic, vulcanized	-	Thermoplastic, vulcanized	-
- Note on materials	Free of copper, PTFE and silicone					

Theoretical gripping force [N] at 6 bar per gripper jaw

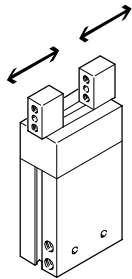

Piston Ø	6	10	16	20	25	35
External gripping	10	40	108	170	264	510
Internal gripping	10	47	120	188	294	577

Characteristic load values per gripper jaw

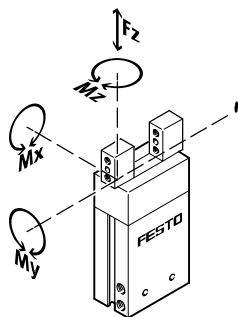

The indicated permissible forces and torques refer to a single gripper jaw. The indicated values include the lever arm, additional applied loads caused

by the workpiece or external gripper fingers, as well as forces which occur during movement. The zero coordinate line (gripper

finger guide) must be taken into consideration for the calculation of torques.

Piston Ø	6	10	16	20	25	35	
Max. permissible force F_z	[N]	14	25	90	150	240	380
Max. permissible torque M_x	[Nm]	0.1	0.5	3.3	6	11	25
Max. permissible torque M_y	[Nm]	0.1	0.5	3.3	6	11	25
Max. permissible torque M_z	[Nm]	0.1	0.5	3.3	6	11	25

Parallel grippers HGP

Technical data

FESTO

Mass moment of inertia [$\text{kgm}^2 \times 10^{-4}$]

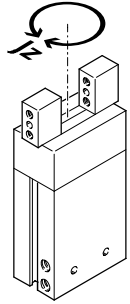

Mass moment of inertia [$\text{kgm}^2 \times 10^{-4}$]
for parallel grippers in relation to the
central axis, without external gripper
fingers, without load.

Piston \varnothing	6	10	16	20	25	35
HGP-...-A	0.01	0.08	0.47	1.49	3.83	12.70
HGP-...-G1	–	0.08	0.47	1.52	3.92	12.83
HGP-...-G2	–	0.08	0.47	1.49	3.84	12.73

Parallel grippers HGP

Technical data

Opening and closing times [ms] at 6 bar as a function of the applied load on the external gripper finger

without external gripper fingers

with external gripper fingers

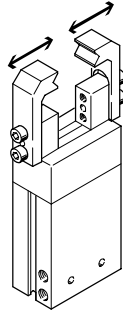
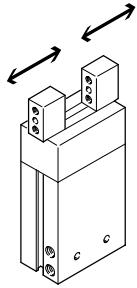

The indicated opening and closing times [ms] have been measured at room temperature and 6 bar operating pressure with vertically mounted gripper and without additional gripper fingers. Load is increased if external gripper fingers are attached. This means that kinetic energy is also increased, as this is determined by gripper finger weight and velocity. If permissible kinetic energy is exceeded, various parts of the gripper may be damaged. This occurs when

the applied load reaches the end position and the cushioning is only able to partially convert the kinetic energy into potential energy and heat energy. It thus becomes apparent that the indicated max. permissible applied load due to the external gripper fingers must be checked and maintained. The grippers must be throttled for greater applied loads. Opening and closing times must then be adjusted accordingly.

Piston Ø		6	10	16	20	25	35
without external gripper fingers							
HGP-...-A	Opening	5	22	44	32	47	77
	Closing	5	31	60	44	50	77
HGP-...-G1	Opening	-	17	39	30	39	71
	Closing	-	29	62	48	60	82
HGP-...-G2	Opening	-	33	66	39	62	90
	Closing	-	29	44	42	49	72
with external gripper fingers as a function of the applied load							
HGP	0.06 N	5	-	-	-	-	-
	0.08 N	10	-	-	-	-	-
	0.1 N	20	-	-	-	-	-
	0.2 N	50	-	-	-	-	-
	0.5 N	-	100	-	-	-	-
	1 N	-	200	100	-	-	-
	1.25 N	-	-	-	100	-	-
	1.5 N	-	300	200	-	100	-
	1.75 N	-	-	-	200	-	-
	2 N	-	-	300	-	200	100
	2.5 N	-	-	-	300	-	-
	3 N	-	-	-	-	300	200
4 N	-	-	-	-	-	300	

Parallel grippers HGP

Technical data

FESTO

Gripping force F_{Grip} per gripper jaw as a function of operating pressure and lever arm x

External and internal gripping (closing and opening)

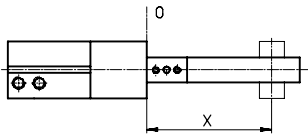

Gripping forces related to operating pressure and lever arm (distance from the zero co-ordinate line shown above

to the pressure point at which the fingers grip the workpiece) can be

determined for the various sizes using the following graphs.

HGP-06-A¹⁾

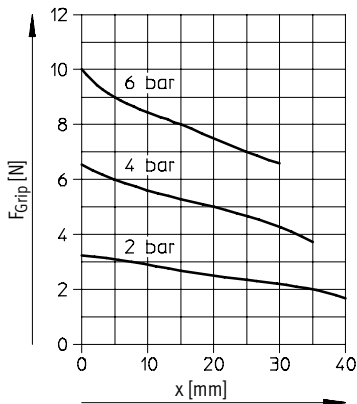

1) Due to the design, the opening and closing gripping forces for HGP-06-A are identical.

HGP-10-A-B

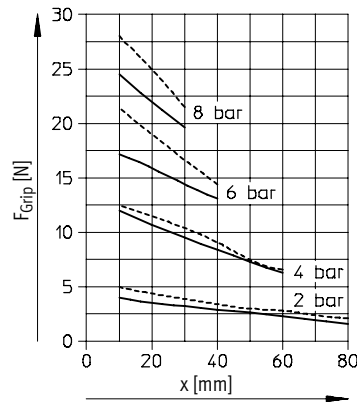

HGP-16-A-B

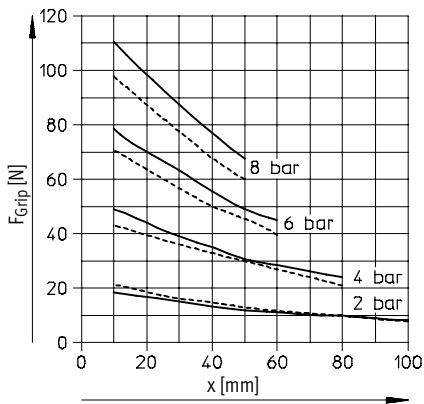

HGP-20-A-B

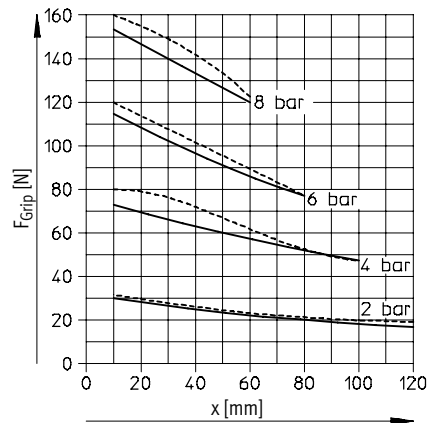

HGP-25-A-B

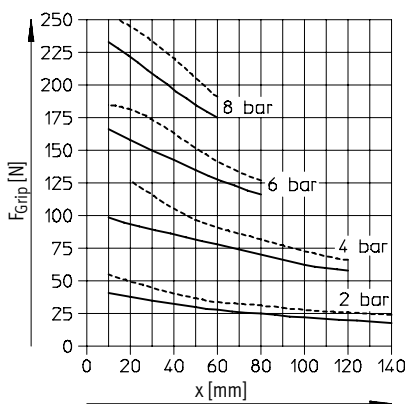

HGP-35-A-B

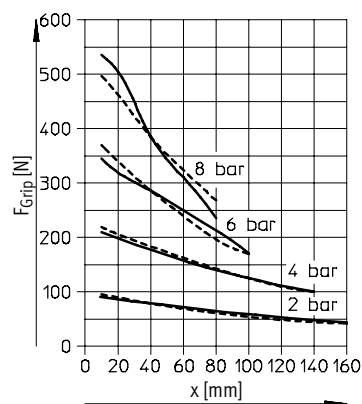

— External gripping (closing)
 - - - Internal gripping (opening)

Handling units
 Standard grippers

7.5

Parallel grippers HGP

Technical data

Spring force F_{Spring} as a function of gripper size and overall stroke length l

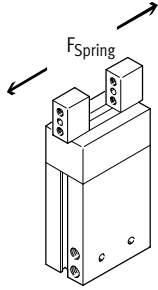

Gripper retention force, opening: the spring forces F_{Spring} of the parallel gripper HGP...-G1 can be determined from the following graphs.

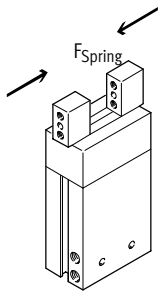
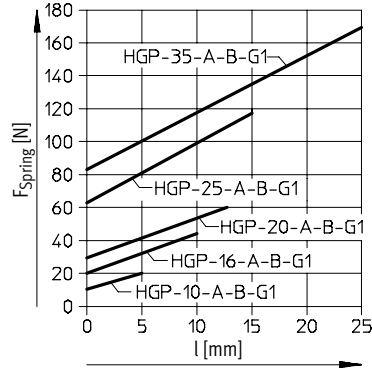

Gripper retention force, closing: the spring forces F_{Spring} of the parallel gripper HGP...-G2 can be determined from the following graphs.

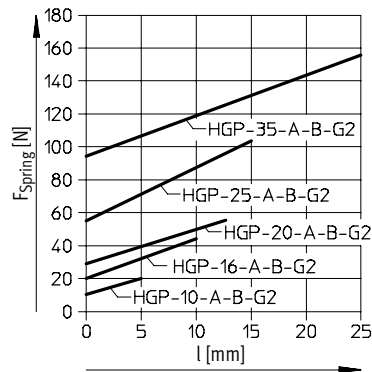

Determination of actual gripping forces for parallel grippers HGP...-G1 and HGP...-G2 depending upon the application

The parallel grippers with integrated spring can be used as:

- single-acting grippers
- grippers with supplementary gripping force and
- grippers with gripping force retention

In order to calculate available gripping forces F_{Gr} (per gripper jaw), the gripping force (F_{Grip}) and spring

force (F_{Spring}) must be combined accordingly.

Application

The resulting gripping force F_{Gr} , conditional on the application, depends on the gripping action (external/internal gripping) and the gripper design (with/without spring return). The spring force is supplemented in accordance with the design and gripping action.

Application	Single-acting	Supplementary gripping force	Gripping force retention
The resulting gripping force F_{Gr} , conditional on the application, depends on the gripping action (external/internal gripping) and the gripper design (with/without spring return). The spring force is supplemented in accordance with the design and gripping action.	<ul style="list-style-type: none"> ■ Gripping with spring force: $F_{Gr} = F_{Spring}$ ■ Gripping with pressure force: $F_{Gr} = F_{Grip} - F_{Spring}$ 	<ul style="list-style-type: none"> ■ Gripping with pressure and spring force: $F_{Gr} = F_{Grip} + F_{Spring}$ 	<ul style="list-style-type: none"> ■ Gripping with spring force: $F_{Gr} = F_{Spring}$

		Pressurised (in gripping action)	Unpressurised
HGP	Internal gripping	$F_{Gr} = F_{Grip}$	$F_{Gr} = 0$
	External gripping	$F_{Gr} = F_{Grip}$	$F_{Gr} = 0$
HGP...-G1	Internal gripping	$F_{Gr} = F_{Grip} + F_{Spring}$	$F_{Gr} = F_{Spring}$
	External gripping	$F_{Gr} = F_{Grip} - F_{Spring}$	$F_{Gr} = 0$
HGP...-G2	Internal gripping	$F_{Gr} = F_{Grip} - F_{Spring}$	$F_{Gr} = 0$
	External gripping	$F_{Gr} = F_{Grip} + F_{Spring}$	$F_{Gr} = F_{Spring}$

Parallel grippers HGP

Technical data

FESTO

Gripping force F_{Grip} per gripper jaw at 6 bar as a function of lever arm x and eccentricity y

External and internal gripping (closing and opening)

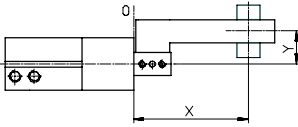

Gripping forces at 2, 4 and 6 bar related to eccentric application of force (distance from the zero co-ordinate line shown opposite to the pressure

point at which the fingers grip the workpiece) and the maximum permissible off-centre point at which

force is applied can be determined for the various sizes using the following graphs.

Calculation example

Given:

HGP-16-A-B

Lever arm $x = 20$ mm

Eccentricity $y = 22$ mm

To be found:

Gripping force at 6 bar

Procedure:

- Determine the intersection xy between lever arm x and eccentricity y in the graph for HGP-16-A-B
 - Draw an arc (with centre at origin) through intersection xy
 - Determine the intersection between the arc and the X axis
 - Read the gripping force
- Result:
Gripping force = approx. 66 N

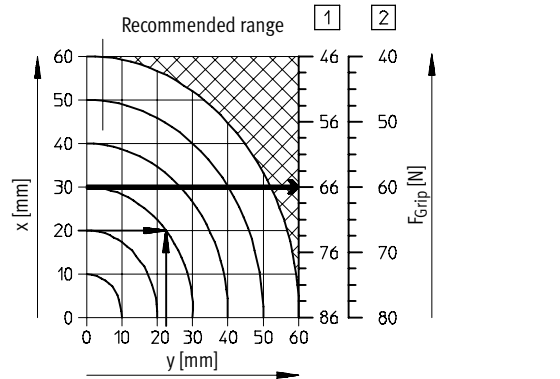

HGP-06-A

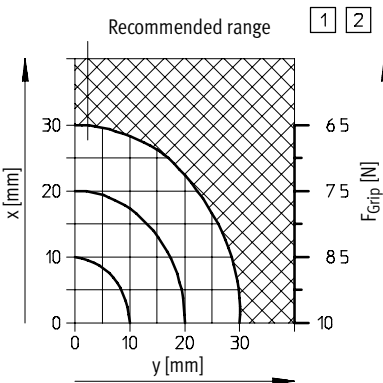

HGP-10-A-B

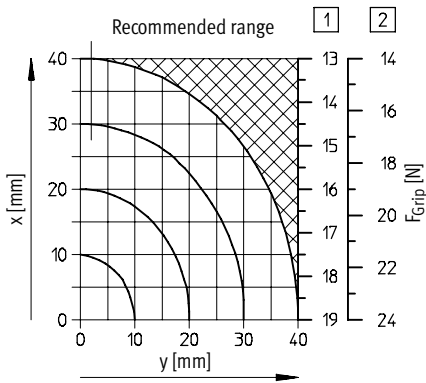

HGP-16-A-B

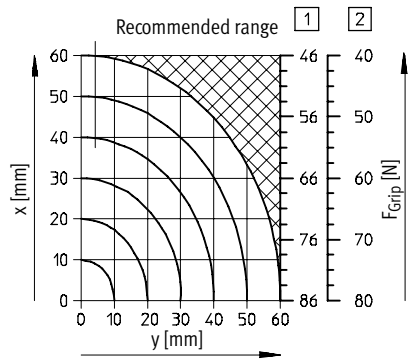

HGP-20-A

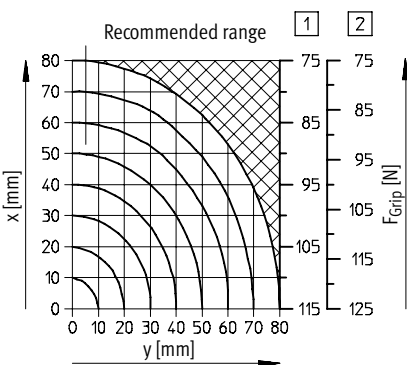

HGP-25-A-B

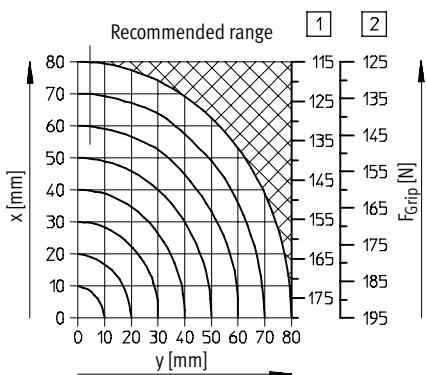

HGP-35-A-B

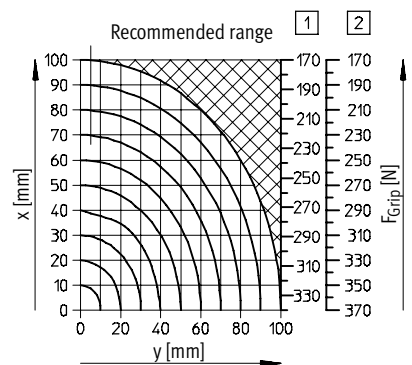

- 1 External gripping (closing)
- 2 Internal gripping (opening)

Parallel grippers HGP

Technical data

FESTO

Dimensions

Download CAD data → www.festo.com/en/engineering

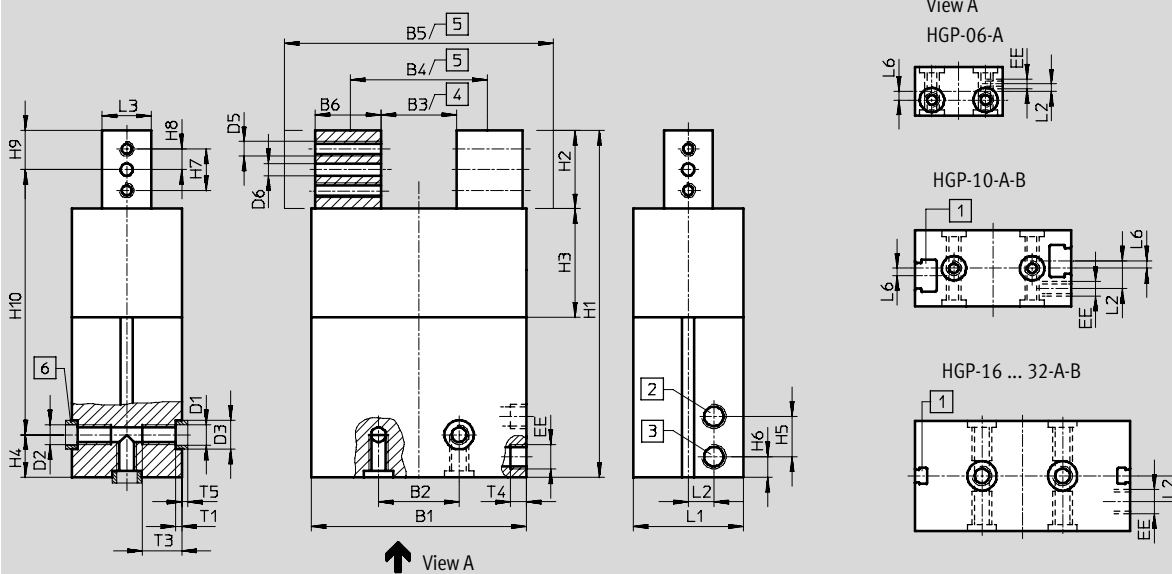

- 1 Sensor slot for proximity sensor SME-8/SMT-8 (not with HGP-06-A). Proximity sensors SME-10/SMT-10 can also be used in combination with the sensor strip HGP-SL-... (can be glued into place).
- 2 Compressed air connection, opening
- 3 Compressed air connection, closing
- 4 Closed
- 5 Open
- 6 Centring sleeves ZBH (2 included in scope of delivery)

with protective dust cap HGP-...-SSK

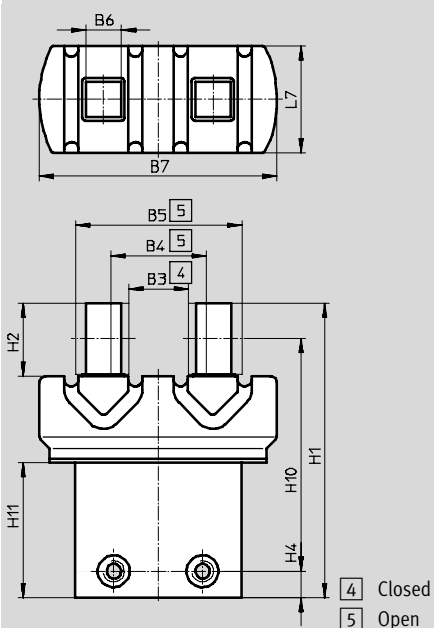

Handling units
Standard grippers

7.5

Parallel grippers HGP

FESTO

Technical data

Type	B1	B2 ¹⁾	B3	B4	B5	B6	B7	D1	D2	D3	D5	D6	EE	H1	H2	H3	H4 ²⁾
		±0.1	±0.5	±0.5	±0.5	-0.03	±0.5	∅		∅ H8/h7		∅ H8					±0.1
HGP-06-A	18	11	6	10	21	5.5	-	3.2	M3	5	M2	1.5	M3	45.5	9.9	10.2	7.5
HGP-10-A-B	32	16	15.8	21.8	35.8	7	-	3.2	M3	5	M3	2	M3	66	15	16	7.5
HGP-16-A-B	47	25	17.8	27.8	53.8	13	-	5.3	M4	7	M4	3	M3	80	20	21.9	7.5
HGP-20-A-B	55.6	25	17.4	30.4	65.4	17.5	-	5.3	M4	7	M4	4	M5	101	27.5	26.1	7.5
HGP-25-A-B	68.2	29	21	36	80	22	-	6.4	M6	9	M5	4	G1/8	121	30	32.2	17.5
HGP-35-A-B	88	33	31	56	110	27	-	8.4	M8	12	M6	5	G1/8	142	31.9	44.8	17.5
with protective dust cap																	
HGP-16-A-B-SSK	47	25	16.4	26.4	46.4	10	67	5.3	M4	7	M4	3	M3	83	20.5	21.9	7.5
HGP-25-A-B-SSK	68.2	29	21	36	66	15	101	6.4	M6	9	M5	4	G1/8	126.8	31.5	32.2	17.5

Type	H5	H6	H7	H8	H9	H10	H11	L1	L2	L3	L6	L7	T1	T3	T4	T5
						±0.2				-0.03			+0.1	+1	+0.5	-0.3
HGP-06-A	7	4	5.8	2.9	5	33	-	10	1.5	5	1.8	-	1.2	-	3.5	1.2
HGP-10-A-B	7	4	8	4	7.5	51	-	15.5	4.2	7	1.5	-	1.2	6	3.5	1.2
HGP-16-A-B	7	4	11	5.5	10	62.5	-	22	5.7	10	-	-	1.6	7.5	3.5	1.4
HGP-20-A-B	10.5	11.5	14	7	12.5	81	-	30	9	12	-	-	1.6	8	6	1.4
HGP-25-A-B	16.5	8.3	16	8	15	88.5	-	37	10.5	15	-	-	2.1	15	6.5	1.9
HGP-35-A-B	16.5	8.5	17	8.5	16	108.5	-	45	10.5	20	-	-	2.6	16	6.5	2.4
with protective dust cap																
HGP-16-A-B-SSK	7	4	11	5.5	10	65.5	38.1	22	5.7	10	-	30	1.6	7.5	3.5	1.4
HGP-25-A-B-SSK	16.5	8.3	16	8	15	94.3	58.8	37	10.5	15	-	47	2.1	15	6.5	1.9

- 1) Tolerance for centring hole: +0.02
 2) Tolerance for centring hole: -0.05

7.5
 Handling units
 Standard grippers

 Note

Due to the distance H5 between the two air connections on types HGP-06/-10/-16 which measures 7 mm, only the following tube fittings can be used

- QSML-M3-3
- QSMLL-M3-3
- QSM-M3-3
- CN-M3-PK-3
- LCN-M3-PK-3
- www.festo.com
- Volume 3

Parallel grippers HGP

FESTO

Technical data

Ordering data						
Piston Ø [mm]	Double-acting without compression spring		Gripper retention force G1 open		Gripper retention force G2 closed	
	Part No.	Type	Part No.	Type	Part No.	Type
6	174 815	HGP-06-A	–		–	
10	197 542	HGP-10-A-B	197 543	HGP-10-A-B-G1	197 544	HGP-10-A-B-G2
16	197 545	HGP-16-A-B	197 546	HGP-16-A-B-G1	197 547	HGP-16-A-B-G2
20	525 889	HGP-20-A-B	525 890	HGP-20-A-B-G1	525 891	HGP-20-A-B-G2
25	197 548	HGP-25-A-B	197 549	HGP-25-A-B-G1	197 550	HGP-25-A-B-G2
35	197 551	HGP-35-A-B	197 552	HGP-35-A-B-G1	197 553	HGP-35-A-B-G2
with protective dust cap						
16	539 636	HGP-16-A-B-SSK	–		–	
25	539 635	HGP-25-A-B-SSK	–		–	

Ordering data – Wearing parts kits		
Piston Ø [mm]	Part No.	Type
6	378 516	HGP-06-A
10	397 376	HGP-10
16	397 377	HGP-16
20	397 378	HGP-20
25	397 397	HGP-25
32	397 380	HGP-35

 Core Range

Parallel grippers HGP

Accessories

FESTO

Sensor strip HGP-SL
can be glued into place

Material:
Wrought aluminium alloy

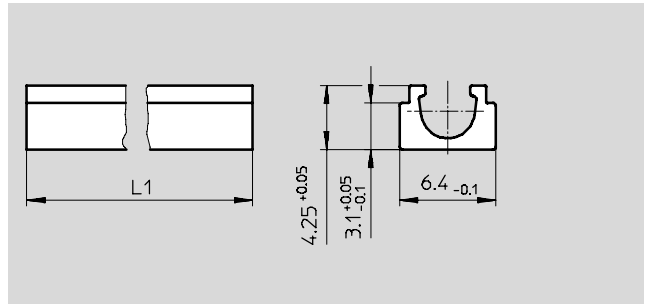
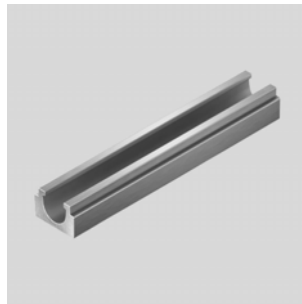

Dimensions and ordering data				
For Ø	L1	Weight	Part No.	Type
[mm]		[g]		
10	35	1.4	535 582	HGP-SL-10-10
16	38	1.5	535 583	HGP-SL-10-16
20	50	2.0	535 584	HGP-SL-10-20
25	58	2.3	535 585	HGP-SL-10-25
35	65	2.6	535 586	HGP-SL-10-35

Three-point grippers HGD

FESTO

Technical data

Function
Double-acting

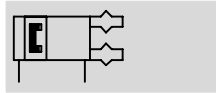

www.festo.com/en/Spare_parts_service

Wearing parts kits
→ 1 / 7.5-24

- Piston Ø
16 ... 50 mm



Repair service

- Stroke
5 ... 12 mm

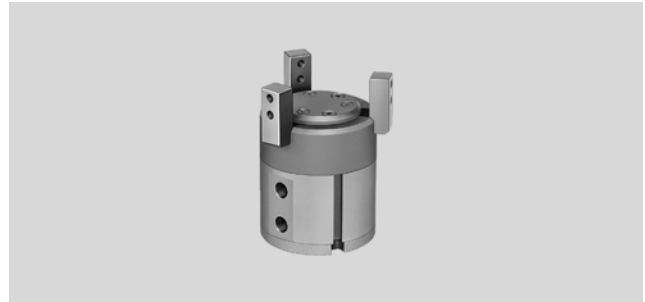

General technical data					
Piston Ø		16	32	50	
Design		Lever			
Mode of operation		Double-acting			
Gripper function		3-point			
Number of gripper jaws		3			
Max. applied load per external gripper finger ¹⁾	[N]	0.08	0.3	0.75	
Stroke	per gripper jaw	[mm]	2.5	3.9	6
	smallest gripping Ø ²⁾	[mm]	23	33.2	50
	largest gripping Ø ²⁾	[mm]	28	41	62
Pneumatic connection		M3	M5	G1/8	
Repetition accuracy ³⁾	[mm]	≤ 0.04			
Max. interchangeability	[mm]	0.2			
Max. operating frequency	[Hz]	4			
Position sensing		Via proximity sensor			
Type of mounting		Via female thread and locating hole			

- 1) Valid for unthrottled operation.
- 2) Without external gripper fingers.
- 3) Concentric to the central shaft.

Operating and environmental conditions				
Piston Ø		16	32	50
Min. operating pressure	[bar]	2		
Max. operating pressure	[bar]	8		
Operating medium		Filtered compressed air, lubricated or unlubricated		
Ambient temperature	[°C]	+5 ... +60		
Corrosion resistance class CRC ¹⁾		2		

- 1) Corrosion resistance class 2 according to Festo standard 940 070
Components requiring moderate corrosion resistance. Externally visible parts with primarily decorative surface requirements which are in direct contact with a normal industrial environment or media such as coolants or lubricating agents.

Weight [g]				
Piston Ø		16	32	50
HGD		110	300	985

Handling units
Standard grippers

7.5

Three-point grippers HGD

Technical data

FESTO

Materials

Sectional view

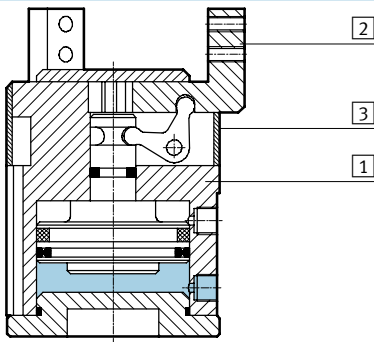

Gripper

1	Housing	Nickel-plated aluminium
2	Gripper jaw	High-alloy steel, nickel-plated
3	Cover cap	Polyacetate
-	Note on materials	Free of copper, PTFE and silicone

Theoretical gripping force [N] at 6 bar per gripper jaw

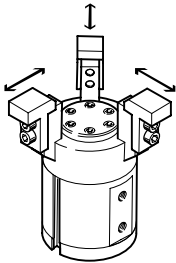

Piston Ø	16	32	50
External gripping	30	130	320
Internal gripping	40	150	350

Characteristic load values at the gripper jaws

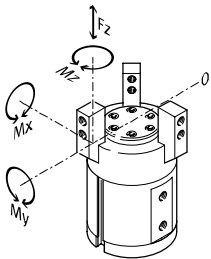

The indicated permissible forces and torques refer to a single gripper jaw. Static forces and torques relate to additional applied loads caused by

the workpiece or external gripper fingers, as well as forces which occur during handling. The zero co-ordinate

line (gripper jaws point of rotation) must be taken into consideration for the calculation of torques.

Piston Ø		16	32	50
Max. permissible force F_z	[N]	34	90	173
Max. permissible torque M_x	[Nm]	0.5	1.6	4.7
Max. permissible torque M_y	[Nm]	0.8	2.8	8.1
Max. permissible torque M_z	[Nm]	0.5	1.9	5.3

Three-point grippers HGD

Technical data

Mass moment of inertia [$\text{kgm}^2 \times 10^{-4}$]

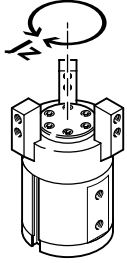

Mass moment of inertia [$\text{kgm}^2 \times 10^{-4}$] for three-point grippers in relation to the central axis, without external gripper fingers, without load.

Piston \varnothing	16	32	50
HGD	0.14	0.79	6.10

Opening and closing times [ms] at 6 bar as a function of the applied load on the external gripper finger

without external gripper fingers

with external gripper fingers

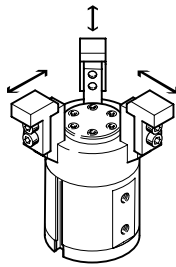
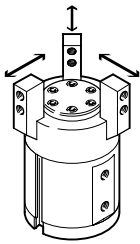

The indicated opening and closing times [ms] have been measured at room temperature and 6 bar operating pressure with vertically mounted gripper and without additional gripper fingers. Load is increased if external gripper fingers are attached. This means that kinetic energy is also increased, as this is determined by gripper finger weight and velocity. If permissible kinetic energy is exceeded, various parts of the gripper may be damaged. This occurs when

the applied load reaches the end position and the cushioning is only able to partially convert the kinetic energy into potential energy and heat energy. It thus becomes apparent that the indicated max. permissible applied load due to the external gripper fingers must be checked and maintained. The grippers must be throttled for greater applied loads. Opening and closing times must then be adjusted accordingly.

Piston \varnothing		16	32	50
without external gripper fingers				
HGD	Opening	5	10	10
	Closing	5	10	10
with external gripper fingers as a function of the applied load				
HGD	0.08 N	5	–	–
	0.11 N	10	–	–
	0.15 N	20	–	–
	0.3 N	50	–	–
	0.5 N	–	100	–
	0.75 N	–	200	–
	1 N	–	300	100
	2 N	–	–	300

Three-point grippers HGD

Technical data

FESTO

Gripping force F as a function of operating pressure and lever arm x

Gripping forces

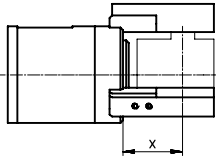

Gripping forces related to operating pressure and lever arm (distance from the zero co-ordinate line shown

opposite to the pressure point at which the external fingers grip the workpiece) can be determined for the

various sizes using the following graphs.

External gripping (closing)

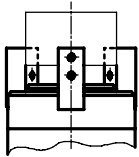

Internal gripping (opening)

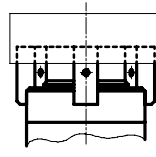

HGD-16-A

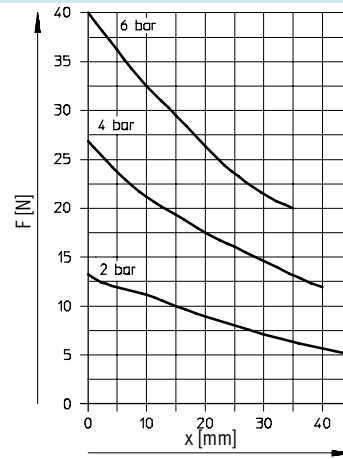
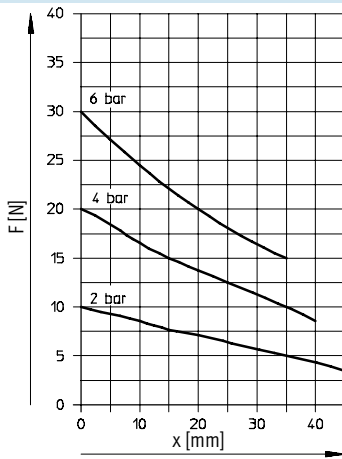

HGD-32-A

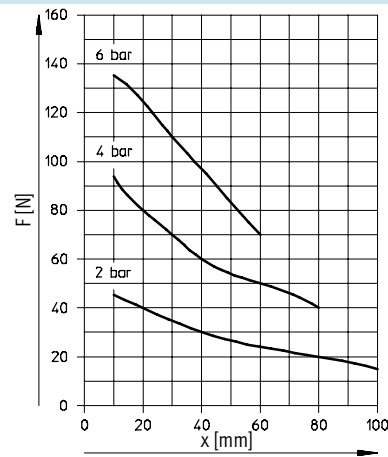
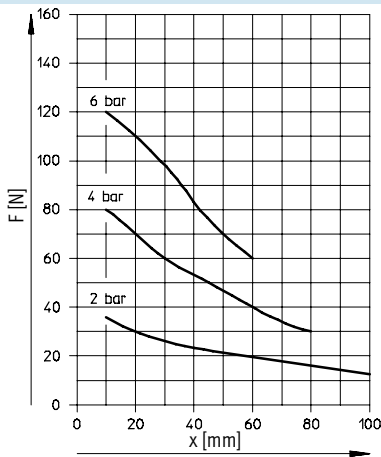

Three-point grippers HGD

Technical data

Gripping force F as a function of operating pressure and lever arm x

External gripping (closing)

Internal gripping (opening)

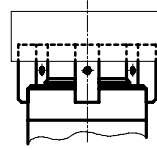
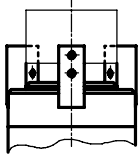

HGD-50-A

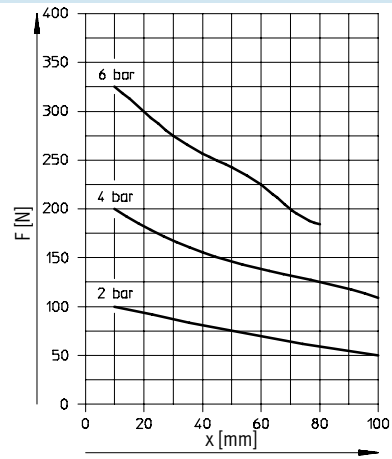
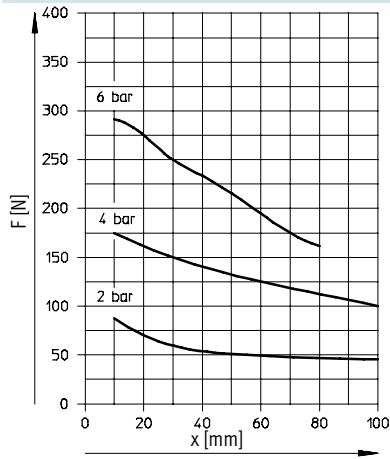

Three-point grippers HGD

Technical data

FESTO

Handling units
Standard grippers

7.5

Dimensions

Download CAD data → www.festo.com/en/engineering

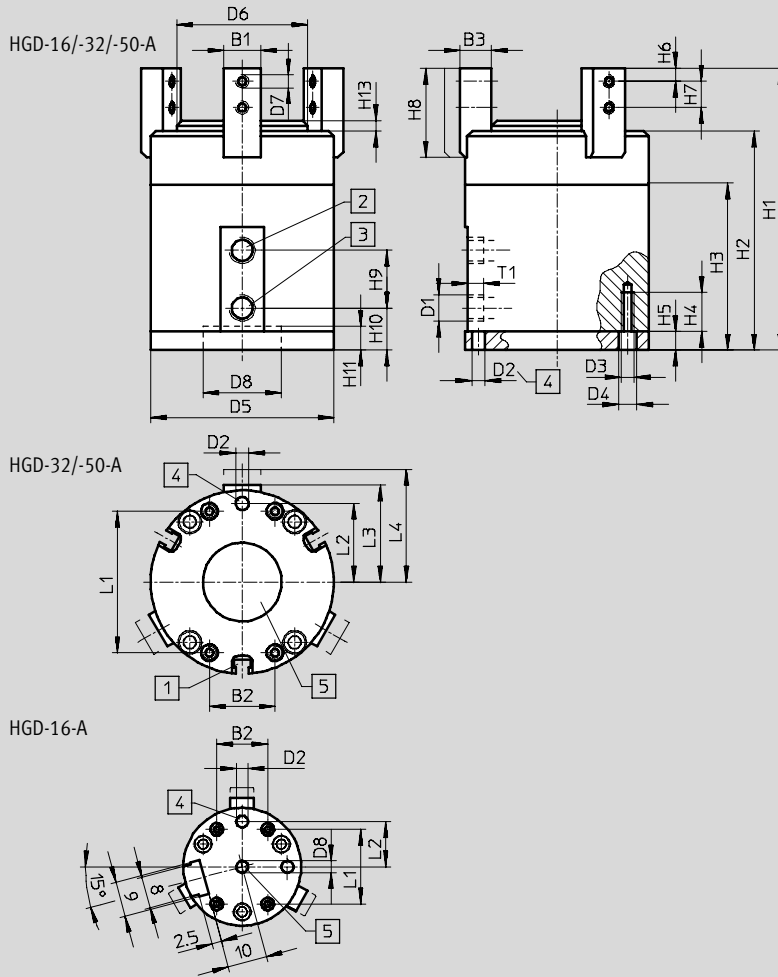

- 1 Sensor slot for proximity sensor SME-8/SMT-8 (not with HGD-16-A)
- 2 Compressed air connection, closing
- 3 Compressed air connection, opening
- 4 Drilled hole for dowel pin (dowel pins not included in scope of delivery)
- 5 Centring hole (user configured)

∅	B1	B2	B3	D1	D2	D3	D4	D5	D6	D7	D8	H1	H2
	-0.02		-0.02/-0.05		∅ H8		∅	∅	∅		∅		
16	6	13	7	M3	3	M3	3.2	30	21	M3	3 H7	60	46
32	10	13	8	M5	4	M3	3.7	45	32.4	M3	20 +0.02/+0.05	78	62
50	14	25	12	G $\frac{1}{8}$	5	M5	6	70	49.4	M5	30 +0.02/+0.05	107.5	83.5

∅	H3	H4	H5	H6	H7	H8	H9	H10	H11	H13	L1	L2	L3	L4	T1
		+1										±0.02			-0.5
16	32.6	8	4.5	3	6	21	12	11	4.5	2	19	11.5	17.5	20	4
32	44	10	6.5	3.5	6.5	22.5	16	11.8	8	3	36	19	24.6	28.5	4
50	56	16	7	5	10	34	22	16	9	4	54	30	37	43	6

Ordering data

Piston ∅	Double-acting	
[mm]	Part No.	Type
16	174 819	HGD-16-A
32	161 837	HGD-32-A
50	161 838	HGD-50-A

Ordering data – Wearing parts kits

Piston ∅	Wearing parts kits	
[mm]	Part No.	Type
16	378 535	HGD-16-A
32	125 694	HGD-32-A
50	125 695	HGD-50-A

Radial grippers HGR

Technical data

Function
Double-acting

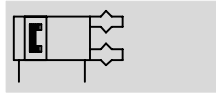

www.festo.com/en/Spare_parts_service

Wearing parts kits
→ 1 / 7.5-31

Piston Ø
10 ... 40 mm

Repair service



General technical data		10	16	25	32	40
Piston Ø		10	16	25	32	40
Design		Rack and pinion				
Mode of operation		Double-acting				
Gripper function		Radial				
Number of gripper jaws		2				
Opening angle	[°]	180				
Pneumatic connection		M3		M5	G1/8	
Repetition accuracy ¹⁾	[mm]	≤ 0.1				
Max. interchangeability	[mm]	0.2				
Max. operating frequency	[Hz]	4				
Position sensing		Via proximity sensor				
Type of mounting		Via female thread and centring hole				

1) End-position drift under constant conditions of use with 100 consecutive strokes in the direction of movement of the gripper jaws.

Operating and environmental conditions		10	16	25	32	40
Piston Ø		10	16	25	32	40
Min. operating pressure	[bar]	2				
Max. operating pressure	[bar]	8				
Operating medium		Filtered compressed air, lubricated or unlubricated				
Ambient temperature	[°C]	+5 ... +60				
Corrosion resistance class CRC ¹⁾		2				

1) Corrosion resistance class 2 according to Festo standard 940 070
Components requiring moderate corrosion resistance. Externally visible parts with primarily decorative surface requirements which are in direct contact with a normal industrial environment or media such as coolants or lubricating agents.

Min. operating pressure p as a function of temperature range t

The required minimum operating pressure may vary depending on the temperature range of the device.

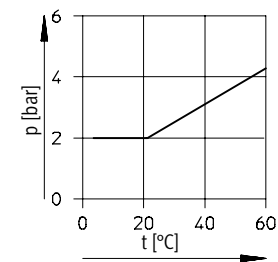

Weight [g]		10	16	25	32	40
Piston Ø		10	16	25	32	40
HGR		39	110	250	420	710

Radial grippers HGR

Technical data

FESTO

Materials

Sectional view

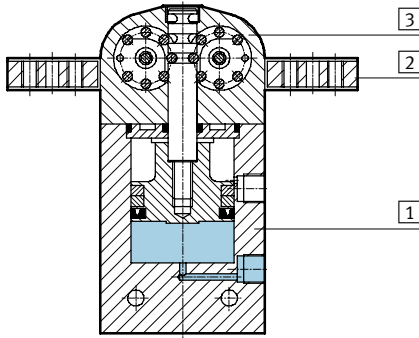

Gripper

1	Housing	Hard anodized aluminium
2	Gripper jaw	Hard anodized aluminium
3	Cover cap	Polyacetate
-	Note on materials	Free of copper, PTFE and silicone

Gripping torque [Ncm] with external gripper fingers

External gripping

Internal gripping

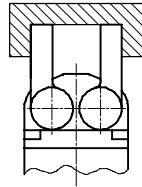
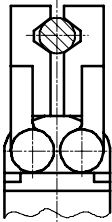

Piston Ø		10	16	25	32	40
at 2 bar	External gripping	2.2	8.3	26.7	50	83.4
	Internal gripping	2.5	9.3	32.7	60	100
at 4 bar	External gripping	4.4	16.7	53.4	100	166.7
	Internal gripping	5	18.7	65.4	120	200
at 6 bar	External gripping	6.6	25	80	150	250
	Internal gripping	7.5	28	98	180	300

Characteristic load values at the gripper jaws

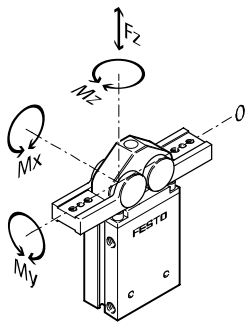

The indicated permissible forces and torques refer to a single gripper jaw. Static forces and torques relate to additional applied loads caused by

the workpiece or external gripper fingers, as well as forces which occur during handling. The zero co-ordinate

line (gripper jaws point of rotation) must be taken into consideration for the calculation of torques.

Piston Ø		10	16	25	32	40
Max. permissible force F_z	[N]	14	25	39	55	83
Max. permissible torque M_x	[Nm]	0.1	0.3	0.6	1	1.9
Max. permissible torque M_y	[Nm]	0.5	1.5	3	4.7	9.9
Max. permissible torque M_z	[Nm]	0.4	1	2	3.2	6.7

Radial grippers HGR

Technical data

Mass moment of inertia [$\text{kgm}^2 \times 10^{-4}$]

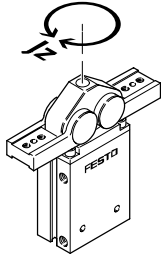

Mass moment of inertia [$\text{kgm}^2 \times 10^{-4}$] for radial grippers in relation to the central axis, without external gripper fingers, without load.

Piston \varnothing	10	16	25	32	40
HGR	0.03	0.14	0.62	1.45	3.58

Opening and closing times [ms] at 6 bar

without external gripper fingers

with external gripper fingers

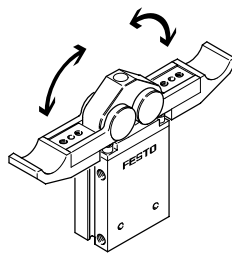
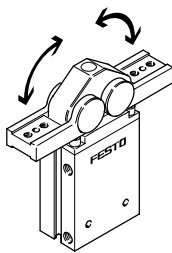

The indicated opening and closing times [ms] have been measured at room temperature and 6 bar operating pressure with vertically mounted gripper and without additional gripper fingers. Load is increased if external gripper fingers are attached. This means that kinetic energy is also increased, as this is determined by gripper finger weight and angular velocity. If permissible kinetic energy is exceeded, various parts of the gripper may be damaged. This occurs

when the applied load reaches the end position and the cushioning is only able to partially convert the kinetic energy into potential energy and heat energy. It thus becomes apparent that the indicated max. permissible applied load due to the external gripper fingers must be checked and maintained. The grippers must be throttled for greater applied loads. Opening and closing times must then be adjusted accordingly.

Piston \varnothing		10	16	25	32	40
without external gripper fingers						
HGR	Opening	5	10	20	30	40
	Closing	5	10	20	30	40
with external gripper fingers → 1 / 7.5-28						

Radial grippers HGR

Technical data

FESTO

Opening and closing times t as a function of gripper finger mass moment of inertia J

HGR-10-A

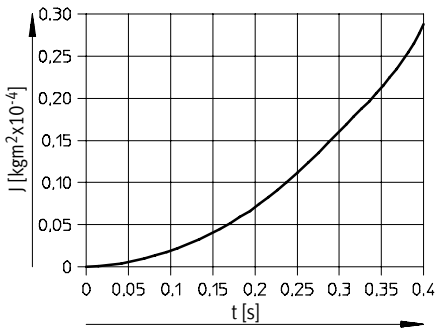

HGR-16-A

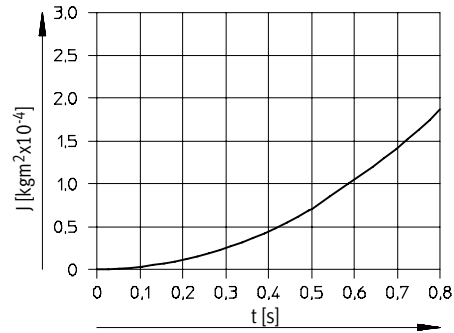

HGR-25-A

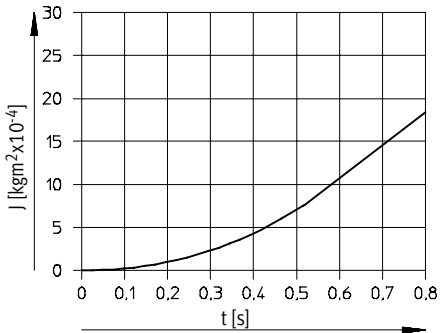

HGR-32-A

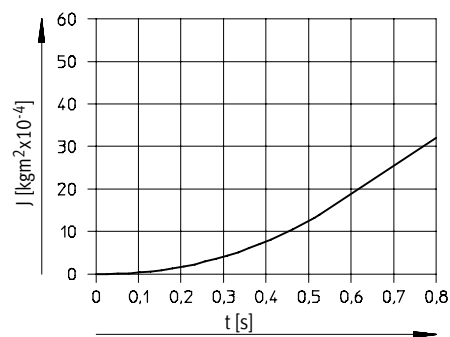

HGR-40-A

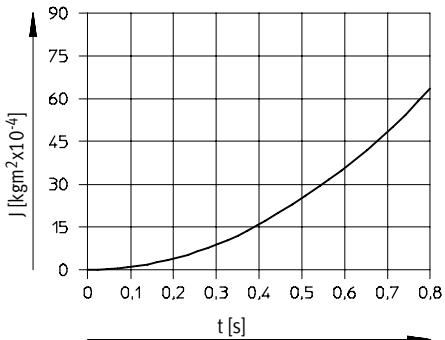

Handling units
Standard grippers

7.5

Radial grippers HGR

Technical data

Gripping force F as a function of operating pressure and lever arm r

Gripping forces

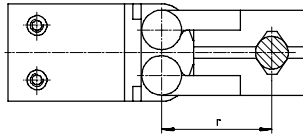

Gripping forces related to operating pressure and lever arm (distance from the zero co-ordinate line shown

opposite to the pressure point at which the external fingers grip the workpiece) can be determined for the

various sizes using the following graphs.

External gripping (closing)

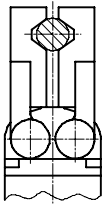

Internal gripping (opening)

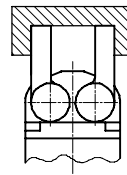

HGR-10-A

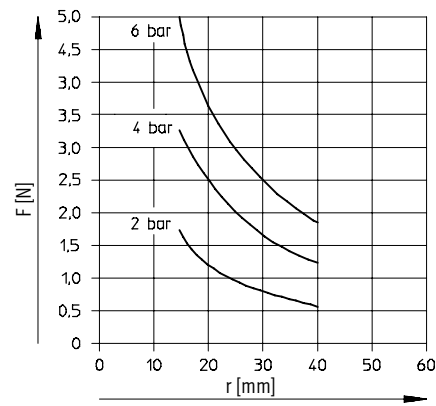
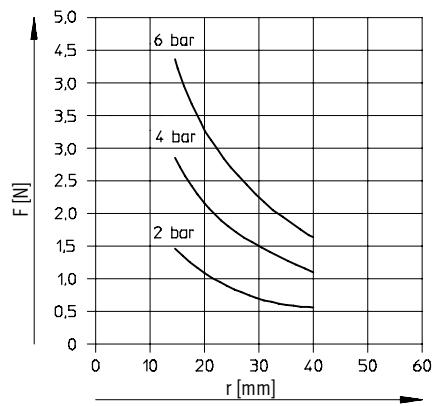

HGR-16-A

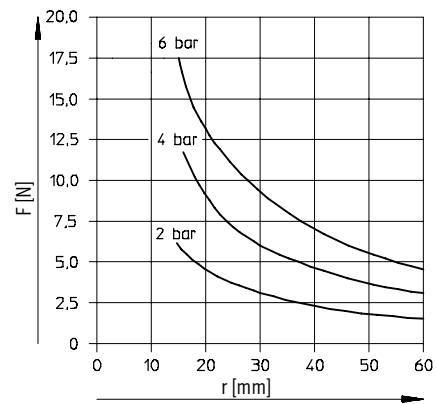
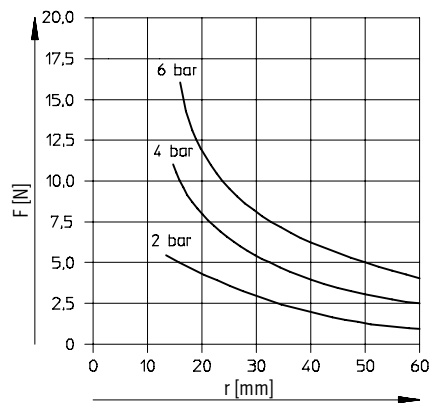

Radial grippers HGR

Technical data

FESTO

Gripping force F as a function of operating pressure and lever arm r

External gripping (closing)

Internal gripping (opening)

HGR-25-A

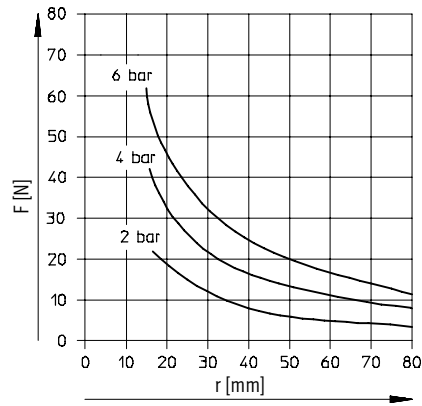
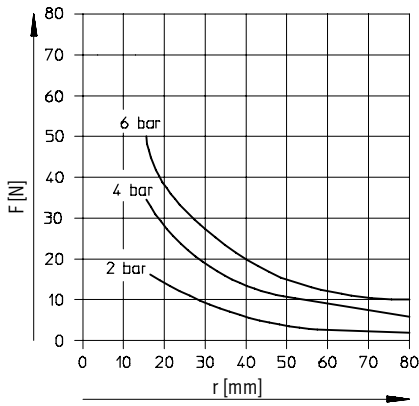

HGR-32-A

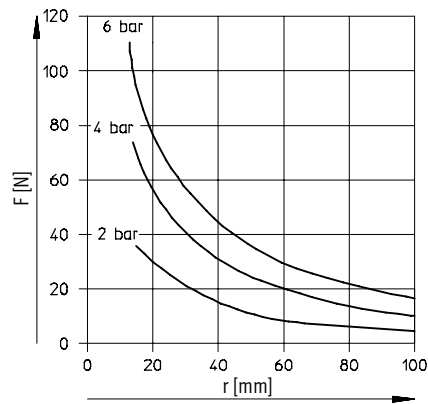
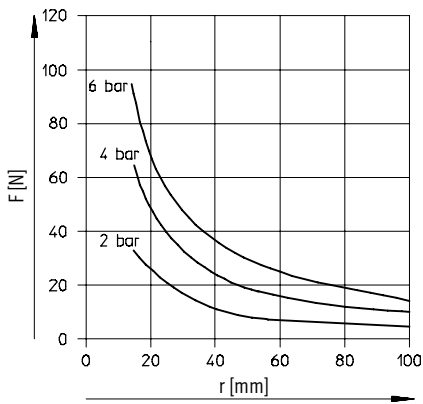

HGR-40-A

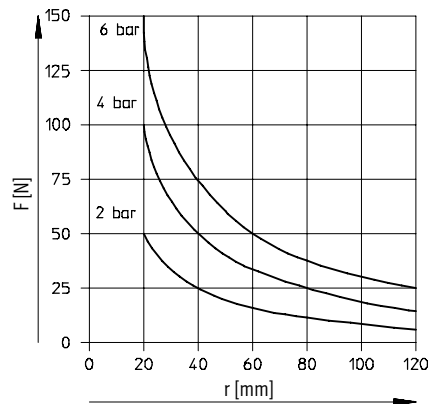
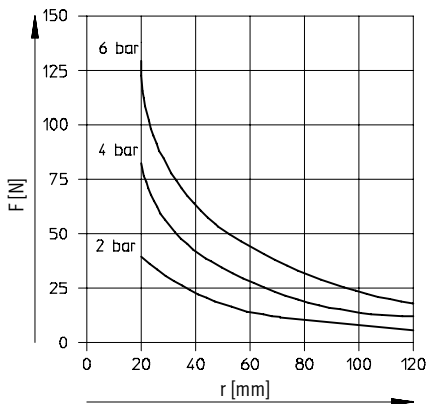

Handling units
Standard grippers

7.5

Radial grippers HGR

Technical data

FESTO

Dimensions

Download CAD data → www.festo.com/en/engineering

1 Sensor slot for proximity sensor SME-8/SMT-8 (not with HGR-10-A)

2 Compressed air connection, closing

3 Compressed air connection, opening

4 Centring sleeves ZBH (2 included in scope of delivery)

∅	B1	B2	B3	B4	B5	B6	D2	D3	D4	D5	D6	EE	H1	H2	H3	H4	H5	H6
		±0.02						∅ H8/h7	∅ +0.1	∅	∅ H8							
10	24	15	11	10.5	5	0.5	M3	5	2.5	M2.5	2	M3	60.8	34.5	16	8.8	8	4
16	33.4	16	16	15.5	6	1	M3	5	2.5	M3	2	M3	88.2	53.2	23	12.25	8	4
25	44	25	19.2	18.6	8	1	M4	7	3.3	M4	3	M5	107.2	63.5	24.7	14.3	10.5	5.25
32	51	29	22.8	21.4	10	1	M6	9	5.1	M5	4	G ¹ / ₈	128.5	75	25	20	14	7
40	59	33	27.6	25.8	12	1	M8	12	6.4	M6	5	G ¹ / ₈	140	80.5	47	8	16	8

∅	H7	H8	H9	H10	H11	H12	L1	L2	L3	L4	L5	L6	T1	T2	T3	T4	T5
	-0.3	±0.05			-0.05	±0.2			+0.01/+0.03			±0.02	+0.1		+1	+0.5	
10	6.25	14.75	49.3	27.5	12.3	12.5	14	2	6.5	10.5	12	2	1.2	12.3	-	3.5	1.2
16	7	20	73.7	53.7	7.5	17.5	19	5.5	10	16	18.5	-	1.2	7	7	4.5	1.2
25	10.25	23.95	87.7	65.5	7.5	20.8	29.5	8.75	13	20	24	-	1.6	7	8	6.5	1.4
32	14	29	101.9	74.5	11	27.5	38	9.5	14	22	26	-	2.1	10	15	6.5	1.9
40	14	33.2	112.5	75.5	17.5	29.7	49	11	20	30	34	-	2.6	15	16	6.5	2.4

Ordering data		
Piston ∅	Double-acting	
[mm]	Part No.	Type
10	174 817	HGR-10-A
16	161 829	HGR-16-A
25	161 830	HGR-25-A
32	161 831	HGR-32-A
40	161 832	HGR-40-A

Ordering data – Wearing parts kits		
Piston ∅		
[mm]	Part No.	Type
10	378 522	HGR-10-A
16	125 668	HGR-16-A
25	125 669	HGR-25-A
32	125 670	HGR-32-A
40	125 671	HGR-40-A

Handling units
Standard grippers

7.5

Angle grippers HGW

Technical data

FESTO

Function
Double-acting

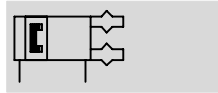

 www.festo.com/en/Spare_parts_service

Wearing parts kits
→ 1 / 7.5-38

 Piston Ø
10 ... 40 mm

 Repair service



General technical data		10	16	25	32	40
Piston Ø		10	16	25	32	40
Design		Lever mechanism				
Mode of operation		Double-acting				
Gripper function		Angled				
Number of gripper jaws		2				
Opening angle	[°]	40				
Pneumatic connection		M3		M5	G1/8	
Repetition accuracy ¹⁾	[mm]	≤ 0.04				
Max. interchangeability	[mm]	0.2				
Max. operating frequency	[Hz]	4				
Position sensing		Via proximity sensor				
Type of mounting		Via female thread and centring hole				

1) End-position drift under constant conditions of use with 100 consecutive strokes in the direction of movement of the gripper jaws.

Operating and environmental conditions		10	16	25	32	40
Piston Ø		10	16	25	32	40
Min. operating pressure	[bar]	2				
Max. operating pressure	[bar]	8				
Operating medium		Filtered compressed air, lubricated or unlubricated				
Ambient temperature	[°C]	+5 ... +60				
Corrosion resistance class CRC ¹⁾		2				

1) Corrosion resistance class 2 according to Festo standard 940 070
Components requiring moderate corrosion resistance. Externally visible parts with primarily decorative surface requirements which are in direct contact with a normal industrial environment or media such as coolants or lubricating agents.

Weight [g]		10	16	25	32	40
Piston Ø		10	16	25	32	40
HGW		39	100	250	420	720

Angle grippers HGW

Technical data

Materials

Sectional view

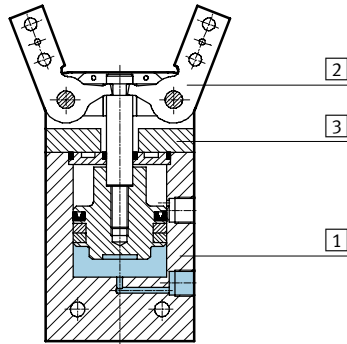

Gripper	
1	Housing Hard anodized aluminium
2	Gripper jaw Nickel-plated tool steel
3	Cover cap Polyacetate
-	Note on materials Free of copper, PTFE and silicone

Gripping torque [Ncm] with external gripper fingers

External gripping

Internal gripping

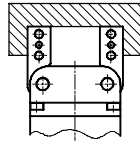
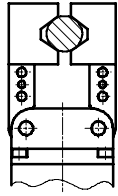

Piston Ø		10	16	25	32	40
at 2 bar	External gripping	3.7	13.4	53.5	100	176.7
	Internal gripping	4.2	15	60	113.4	193.4
at 4 bar	External gripping	7.4	26.7	106.7	200	353.4
	Internal gripping	8.4	30	120	226.7	386.7
at 6 bar	External gripping	11	40	160	300	530
	Internal gripping	12.5	45	180	340	580

Characteristic load values at the gripper jaws

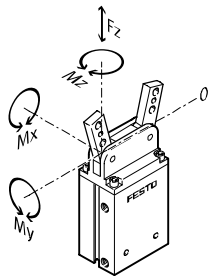

The indicated permissible forces and torques refer to a single gripper jaw. Static forces and torques relate to additional applied loads caused by

the workpiece or external gripper fingers, as well as forces which occur during handling. The zero co-ordinate

line (gripper jaws point of rotation) must be taken into consideration for the calculation of torques.

Piston Ø		10	16	25	32	40
Max. permissible force F_z	[N]	16	31	54	74	124
Max. permissible torque M_x	[Nm]	0.3	0.9	1.7	3	5.7
Max. permissible torque M_y	[Nm]	0.1	0.3	0.6	1	2.2
Max. permissible torque M_z	[Nm]	0.2	0.5	1.1	1.8	3.6

Angle grippers HGW

Technical data



Mass moment of inertia [$\text{kgm}^2 \times 10^{-4}$]

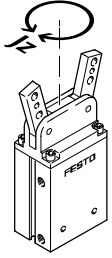

Mass moment of inertia [$\text{kgm}^2 \times 10^{-4}$] for angle grippers in relation to the central axis, without external gripper fingers, without load.

Piston Ø	10	16	25	32	40
HGW	0.03	0.13	0.60	1.48	3.54

Opening and closing times [ms] at 6 bar

without external gripper fingers

with external gripper fingers

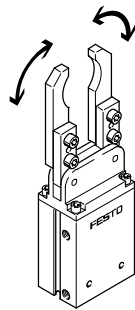
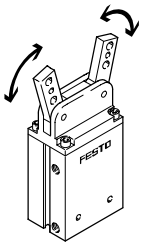

The indicated opening and closing times [ms] have been measured at room temperature and 6 bar operating pressure with vertically mounted gripper and without additional gripper fingers. Load is increased if external gripper fingers are attached. This means that kinetic energy is also increased, as this is determined by gripper finger weight and angular velocity. If permissible kinetic energy is exceeded, various parts of the gripper may be damaged. This occurs

when the applied load reaches the end position and the cushioning is only able to partially convert the kinetic energy into potential energy and heat energy. It thus becomes apparent that the indicated max. permissible applied load due to the additional gripper fingers must be checked and maintained. The grippers must be throttled for greater applied loads. Opening and closing times must then be adjusted accordingly.

Piston Ø		10	16	25	32	40
without external gripper fingers						
HGW	Opening	5	10	10	10	20
	Closing	5	10	10	10	20
with external gripper fingers → 1 / 7.5-35						

Angle grippers HGW

Technical data

FESTO

Opening and closing times t as a function of gripper finger mass moment of inertia J

HGW-10-A

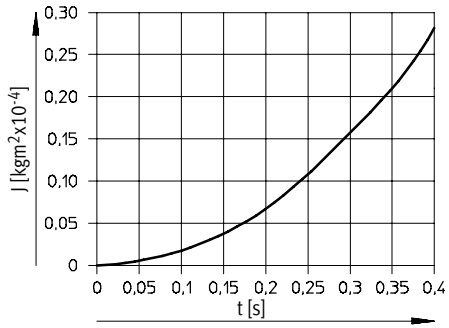

HGW-16-A

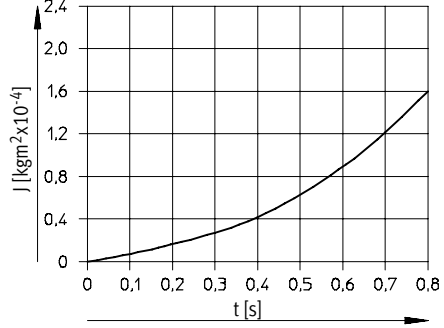

HGW-25-A

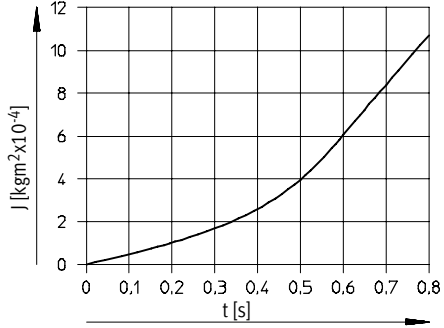

HGW-32-A

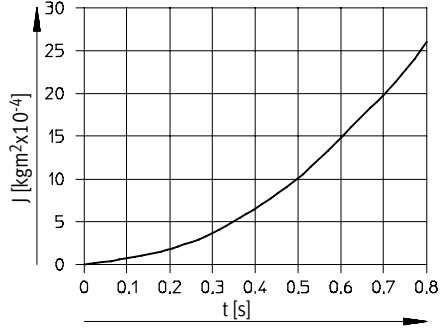

HGW-40-A

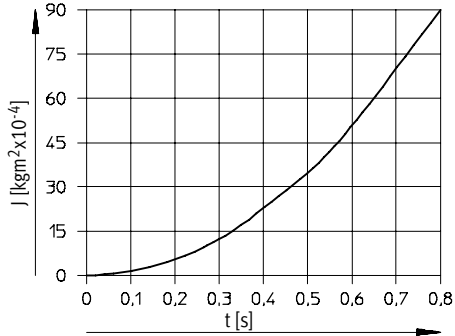

Handling units
Standard grippers

7.5

Angle grippers HGW

Technical data

FESTO

Gripping force F as a function of operating pressure and lever arm r

Gripping forces

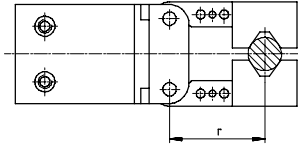

Gripping forces related to operating pressure and lever arm (distance from the zero co-ordinate line shown

opposite to the pressure point at which the external fingers grip the workpiece) can be determined for the

various sizes using the following graphs.

External gripping (closing)

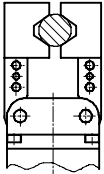

Internal gripping (opening)

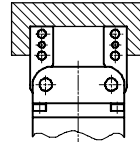

HGW-10-A

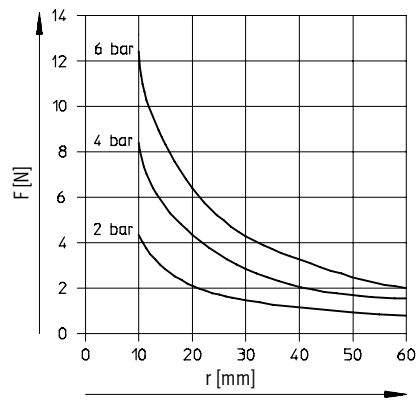
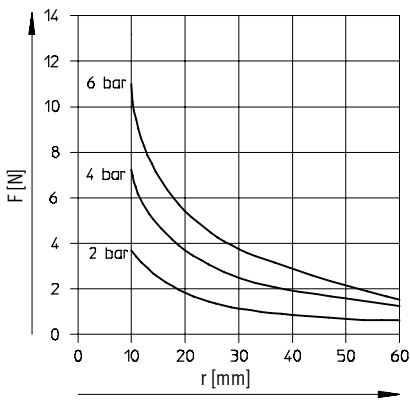

HGW-16-A

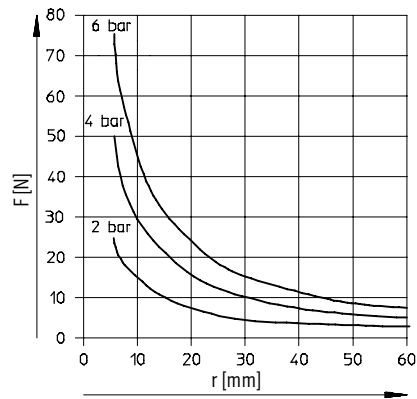
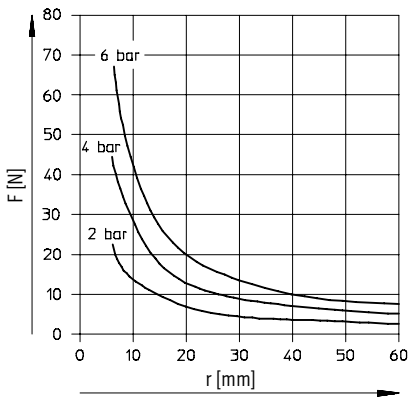

Angle grippers HGW

Technical data

Gripping force F as a function of operating pressure and lever arm r

External gripping (closing)

Internal gripping (opening)

HGW-25-A

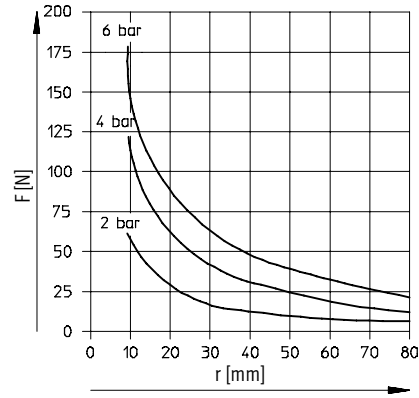
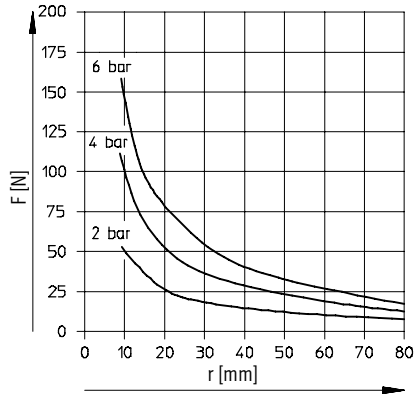

HGW-32A

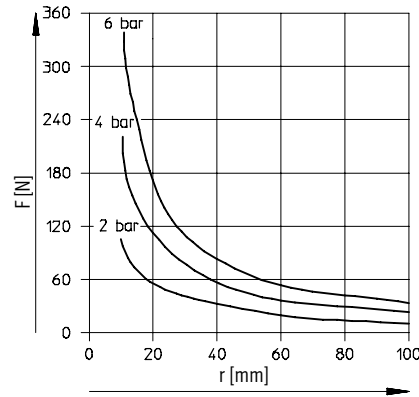
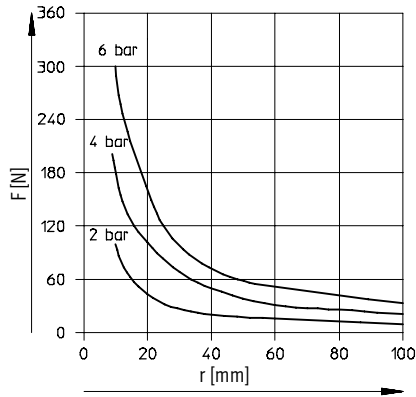

HGW-40A

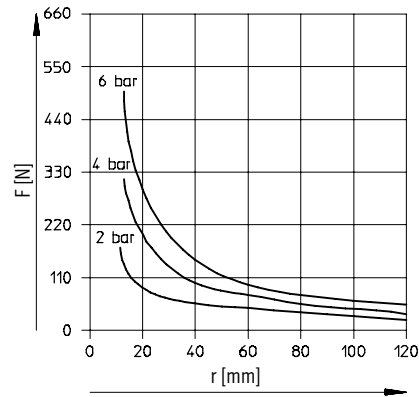
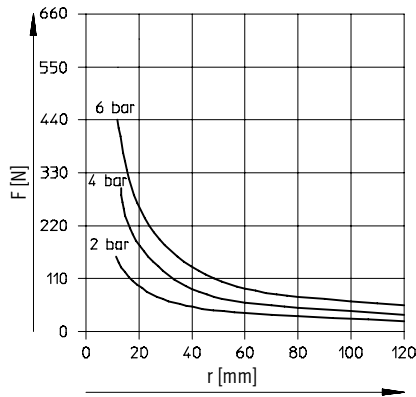

Angle grippers HGW

Technical data

FESTO

Dimensions

Download CAD data → www.festo.com/en/engineering

View A
HGW-10-A

View A
HGW-16 ... 40-A

1 Sensor slot for proximity sensor SME-8/SMT-8 (not with HGW-10-A)

2 Compressed air connection, closing

3 Compressed air connection, opening

4 Centring sleeves ZBH (2 included in scope of delivery)

∅	B1	B2	B3	B4	B5	D2	D3	D4	D5	D6	EE	H1	H2	H3	H4	H5
		±0.02	±0.02		-0.02/-0.05		∅ H8/h7	∅ +0.1	∅ H8	∅						
10	24	15	17	9.75	5.5	M3	5	2.5	2	2.2	M3	56.3	34.5	16	8.8	7
16	33.4	16	24	13	8	M3	5	2.5	2.5	3.2	M3	81	53.2	23	12.25	9
25	44	25	32	18	10	M4	7	3.3	3	3.2	M5	100	63.5	24.7	14.3	11
32	51	29	37	20.5	12	M6	9	5.1	3	4.3	G1/8	116	73	25	20	13
40	59	33	42	23.5	15	M8	12	6.4	4	5.3	G1/8	129	79.5	47	8	14

∅	H6	H7	H8	H9	H10	H11	L1	L2	L3	L4	L6	T1	T2	T3	T4	T5
			±0.05			-0.05			-0.01/-0.02		±0.02	+0.1		+1	+0.5	
10	3.5	5.75	10.75	44.8	27.5	12.3	14	2	3	7	2	1.2	12.3	-	3.5	1.2
16	4.5	7.5	13.7	65.5	52.3	7.5	19	5.5	4	10	-	1.2	7	7	4.5	1.2
25	5.5	8.8	18.7	80.7	65	7.5	29.5	8.75	5	14	-	1.6	7	8	6.5	1.4
32	6.5	11	22	92.5	72	11	38	9.5	6	17	-	2.1	10	15	6.5	1.9
40	7	12	25.5	103	74	17.5	49	11	8	21	-	2.6	15	16	6.5	2.4

Ordering data

Piston ∅	Double-acting	
[mm]	Part No.	Type
10	174 818	HGW-10-A
16	161 833	HGW-16-A
25	161 834	HGW-25-A
32	161 835	HGW-32-A
40	161 836	HGW-40-A



Ordering data – Wearing parts kits

Piston ∅	Wearing parts kits	
[mm]	Part No.	Type
10	378 527	HGW-10-A
16	125 680	HGW-16-A
25	125 681	HGW-25-A
32	125 682	HGW-32-A
40	125 683	HGW-40-A

Standard grippers

Accessories

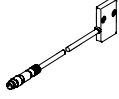
FESTO

Ordering data					
	For type	Weight [g]	Part No.	Type	PU ¹⁾
Proximity sensor SMH-S1					Technical data → NO TAG
Proximity sensor SMH-S1					Technical data → www.festo.com
	HGP-06	20	175 710	SMH-S1-HGP06	
	HGD-16	30	175 713	SMH-S1-HGD16	
	HGR-10	20	175 712	SMH-S1-HGR10	
	HGW-10	20	175 711	SMH-S1-HGW10	
Evaluation unit SMH-AE1					Technical data → NO TAG
Evaluation unit SMH-AE1					Technical data → www.festo.com
	HGP-6	170	175 708	SMH-AE1-PS3-M12	
	HGD-16				
	HGR-10	170	175 709	SMH-AE1-NS3-M12	
	HGW-10				
Centring sleeves ZBH					Technical data → NO TAG
Centring sleeves ZBH					Technical data → www.festo.com
	HGP-06, 10	1	189 652	ZBH-5	10
	HGR-10, 16				
	HGW-10, 16				
	HGP-16, 20	1	186 717	ZBH-7	10
	HGR-25				
	HGW-25				
	HGP-25	1	150 927	ZBH-9	10
	HGR-32				
	HGW-32				
	HGP-35	1	189 653	ZBH-12	10
	HGR-40				
	HGW-40				
	HGW-40				

1) Packaging unit quantity

 Core Range



Standard grippers



Accessories





FESTO

Handling units
Standard grippers

7.5

Ordering data – Proximity sensors for slot type 8, magneto-resistive							Technical data → NO TAG		
Ordering data – Proximity sensors for slot type 8, magneto-resistive							Technical data → www.festo.com		
	Assembly	Switch output	Electrical connection			Cable length [m]	Part No.	Type	
			Cable	Plug M8	Plug M12				
NO contact									
	Insertable from above	PNP	3-core	–	–	2.5	525 898	SMT-8F-PS-24V-K2,5-OE	⊖
		NPN	3-core	–	–	2.5	525 909	SMT-8F-NS-24V-K2,5-OE	⊖
		–	2-core	–	–	2.5	525 908	SMT-8F-ZS-24V-K2,5-OE	⊖
		PNP	–	3-pin	–	0.3	525 899	SMT-8F-PS-24V-K0,3-M8D	⊖
		NPN	–	3-pin	–	0.3	525 910	SMT-8F-NS-24V-K0,3-M8D	⊖
	Insertable from end, flush with the cylinder profile	PNP	3-core	–	–	2.5	175 436	SMT-8-PS-K-LED-24-B	⊖
		–	3-pin	–	–	0.3	175 484	SMT-8-PS-S-LED-24-B	⊖
		–	3-pin	–	–	0.3	525 900	SMT-8F-PS-24V-K0,3-M12	⊖
NC contact									
	Insertable from above	PNP	3-core	–	–	7.5	525 911	SMT-8F-PO-24V-K7,5-OE	⊖

Ordering data – Proximity sensors for slot type 8, magnetic reed							Technical data → NO TAG	
Ordering data – Proximity sensors for slot type 8, magnetic reed							Technical data → www.festo.com	
	Assembly	Electrical connection		Cable length [m]	Part No.	Type		
		Cable	Plug M8					
NO contact								
	Insertable from above	3-core	–	2.5	525 895	SME-8F-DS-24V-K2,5-OE	⊖	
		–	–	5.0	525 897	SME-8F-DS-24V-K5,0-OE	⊖	
		2-core	–	2.5	525 907	SME-8F-ZS-24V-K2,5-OE	⊖	
		–	3-pin	0.3	525 896	SME-8F-DS-24V-K0,3-M8D	⊖	
	Insertable from end, flush with the cylinder profile	3-core	–	2.5	150 855	SME-8-K-LED-24	⊖	
		–	3-pin	0.3	150 857	SME-8-S-LED-24	⊖	
		–	3-pin	0.3	150 857	SME-8-S-LED-24	⊖	
NC contact								
	Insertable from above	3-core	–	7.5	525 906	SME-8F-DO-24V-K7,5-OE	⊖	





Ordering data – Plug sockets							Technical data → NO TAG	
Ordering data – Plug sockets							Technical data → www.festo.com	
	Assembly	Switch output		Connection	Cable length [m]	Part No.	Type	
		PNP	NPN					
Straight socket								
	Union nut M8	■	■	3-pin	2.5	159 420	SIM-M8-3GD-2,5-PU	
		■	■		5	159 421	SIM-M8-3GD-5-PU	
	Union nut M12	■	■	3-pin	2.5	159 428	SIM-M12-3GD-2,5-PU	
		■	■		5	159 429	SIM-M12-3GD-5-PU	
Angled socket								
	Union nut M8	■	■	3-pin	2.5	159 422	SIM-M8-3WD-2,5-PU	
		■	■		5	159 423	SIM-M8-3WD-5-PU	
	Union nut M12	■	■	3-pin	2.5	159 430	SIM-M12-3WD-2,5-PU	
		■	■		5	159 431	SIM-M12-3WD-5-PU	





Core Range











Standard grippers

Accessories

FESTO

Ordering data – Proximity sensors for slot type 10, magneto-resistive							Technical data → NO TAG		
Ordering data – Proximity sensors for slot type 10, magneto-resistive							Technical data → www.festo.com		
	Assembly	Switch output	Electrical connection		Cable length [m]	Connection direction	Part No.	Type	
			Cable	Plug M8					
NO contact									
	Insertable from above	PNP	3-core	–	2.5	In-line	525 915	SMT-10F-PS-24V-K2,5L-OE	
			–	3-pin	0.3	In-line	525 916	SMT-10F-PS-24V-K0,3L-M8D	
			–	–	–	Lateral	526 675	SMT-10F-PS-24V-K0,3Q-M8D	
	Insertable from end	PNP	–	3-pin	0.3	In-line	173 220	SMT-10-PS-SL-LED-24	
			3-core	–	2.5	–	173 218	SMT-10-PS-KL-LED-24	

Ordering data – Proximity sensors for slot type 10, magnetic reed							Technical data → NO TAG	
Ordering data – Proximity sensors for slot type 10, magnetic reed							Technical data → www.festo.com	
	Assembly	Electrical connection		Cable length [m]	Connection direction	Part No.	Type	
		Cable	Plug M8					
NO contact								
	Insertable from above	–	3-pin	0.3	In-line	525 914	SME-10F-DS-24V-K0,3L-M8D	
		3-core	–	2.5	In-line	525 913	SME-10F-DS-24V-K2,5L-OE	
		2-core	–	–	–	526 672	SME-10F-ZS-24V-K2,5L-OE	
	Insertable from end	–	3-pin	0.3	In-line	173 212	SME-10-SL-LED-24	
		3-core	–	2.5	–	173 210	SME-10-KL-LED-24	

Ordering data – Plug sockets							Technical data → NO TAG	
Ordering data – Plug sockets							Technical data → www.festo.com	
	Assembly	Switch output		Connection	Cable length [m]	Part No.	Type	
		PNP	NPN					
Straight socket								
	Union nut M8			3-pin	2.5	159 420	SIM-M8-3GD-2,5-PU	
					5	159 421	SIM-M8-3GD-5-PU	
Angled socket								
	Union nut M8			3-pin	2.5	159 422	SIM-M8-3WD-2,5-PU	
					5	159 423	SIM-M8-3WD-5-PU	

 Core Range