



- High vacuum levels of up to 93%
- Easy connection of holders and suction cups
- Lightweight and compact design
- No wearing parts
- Long service life
- Vacuum monitoring with vacuum switch



Vacuum generators

Key features

FESTO

Product overview

Vacuum generator

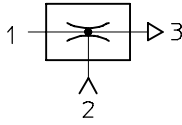

All Festo vacuum generators have a single-stage design and operate according to the venturi principle. The product families described below

have been designed for a wide range of applications. The different performance classes of the individual

product families make it possible to select vacuum generators tailored to suit specific requirements.

Standard and inline ejectors

VN-...

→ 6 / 1.1-9



- Nominal size
0.45 ... 3 mm
- Max. vacuum
93%
- Temperature range
0 ... +60 °C
- A range of extremely effective generators suitable for use directly in the workplace
- Available as straight or T-shaped housing
- Low space requirement
- Low-cost
- No wearing parts
- Extremely fast evacuation time
- Vacuum switch (optional)

VAD-.../VAK-...

→ 6 / 1.1-35



- Nominal size
0.5 ... 1.5 mm
- Max. vacuum
80%
- Temperature range
-20 ... +80 °C
- Range of vacuum generators with sturdy aluminium casing
- VAK-...: Built-in reservoir
VAD-...: Connection for additional external reservoir
- Maintenance-free
- VAK-...: Reliable setting down of workpieces

Vacuum generators

Key features

FESTO

Compact ejectors

VADM-...VADMI-...

→ NO TAG



- Nominal size
0.45 ... 3 mm
- Max. vacuum
84%
- Temperature range
0 ... +60 °C
- Compact design
- Minimal installation work required
- Short response times
- Built-in solenoid valve (on/off)
- VADMI-...: Additional built-in solenoid valve for ejector pulse
- Filter with display
- Air-saving circuit (optional)
- Vacuum switch (optional)
- Reliable setting down of workpieces

VAD-M-.../VAD-M...-I-...

→ NO TAG

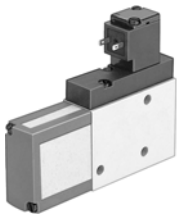

- Nominal size
0.7 ... 2 mm
- Max. vacuum
85%
- Temperature range
0 ... +40 °C
- Compact design
- Minimal installation work required
- Short response times
- Built-in solenoid valve (on/off)
- VAD-M-I-...: Additional built-in solenoid valve for ejector pulse
- Reliable setting down of workpieces

Vacuum generators VN

Features

FESTO

At a glance

- Vacuum generators for high vacuum levels of up to 93%.
- Laval nozzles in six nominal sizes:
 - 0.45 mm
 - 0.7 mm
 - 0.95 mm
 - 1.4 mm
 - 2.0 mm
 - 3.0 mm
- Vacuum generators for high suction rates resulting in very short evacuation times
- Low space requirement
- Compact and sturdy design
- Wear-resistant and maintenance-free
- Modular system: Large selection of different types
- Can be used directly in the workplace, making them very effective
- Plastic housing
- Versatile connection options:
 - Push-in connector QS
 - Screw-in thread
 - Push-in sleeve
 - Screw-in silencer
- Easy mounting thanks to the double-sided latching function of the mounting plate
- With or without integrated vacuum switch to monitor the vacuum with PNP output

Two housing types

Standard T-type

Connection options:

- QS push-in connectors
- Female thread
- Male thread
- Silencers

Mounting options:

- Direct mounting with screws
- Indirect mounting by latching onto a mounting plate. This plate is suitable for H-rails 35x7.5 to DIN EN 50 022.

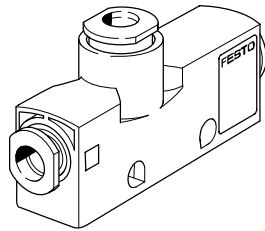

In-line version

Connection options:

- QS push-in connectors
- Push-in sleeve

Mounting options:

Extremely compact housing with supply and vacuum port arranged in a line and with unducted exhaust air. As a result, this housing type can be installed directly into the tubing line.

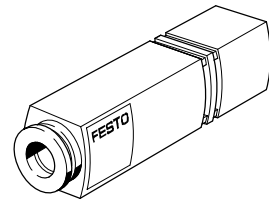

Two operating principles

Standard

- T-type housing

Design:

Supply port at 90° to vacuum port. The drawn-in flow is diverted 90° from V to R.

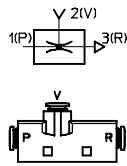

In-line

- T-type housing with exhaust port
- Straight housing without exhaust port for space-saving assembly in a tubing line or directly in the suction cup holder

Design:

Supply and vacuum ports arranged in-line.

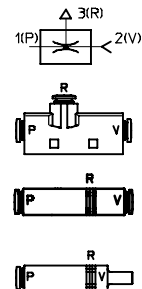

Vacuum generators VN

Features

Two variants

High vacuum

up to 93%

Vacuum p_u as a function of operating pressure p_1

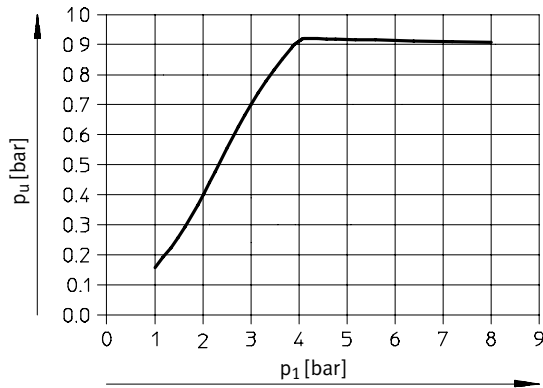

High suction volume

up to 339 l/min which results in very short evacuation times

Suction rate q_{ns} as a function of operating pressure p_1

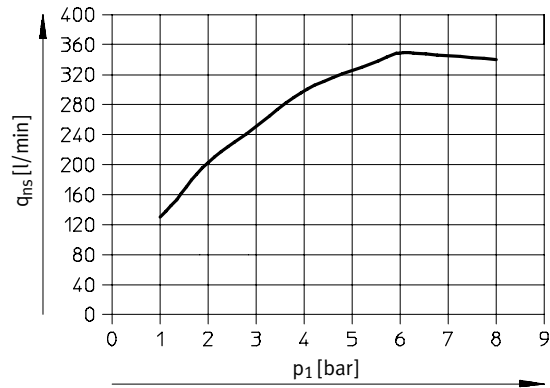

System comparison

High vacuum – high suction volume

The first type of generator has been optimised for the generation of high vacuum at comparatively lower suction flow rates.

The second type of generator, on the other hand, can achieve very short evacuation times because of the high suction flow rate at relatively low vacuum.

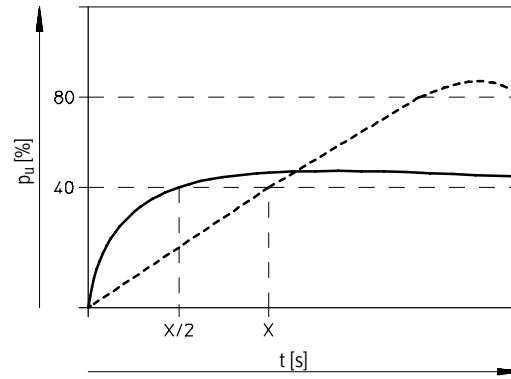

----- High vacuum
 ——— High suction volume

Vacuum generators VN

Product range overview

FESTO

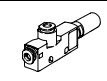
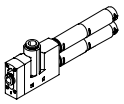
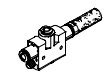
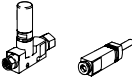
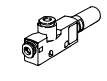
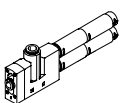
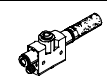
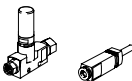
Function	Version	Type	Nominal size [mm]	Housing width						Supply port (1)		
				T-type					Inline		Push-in connector PQ	Female thread PI
				10 [mm]	14 [mm]	16 [mm]	18 [mm]	24 [mm]	10 [mm]	13 [mm]		
High vacuum	Standard H											
		VN-05	0.45	■	-	-	-	-	-	-	■	■
				-	■	-	-	-	-	-	■	■
		VN-07	0.7	■	-	-	-	-	-	-	■	■
				-	■	-	-	-	-	-	■	■
		VN-10	0.95	-	■	-	■	-	-	-	■	■
				-	-	-	■	-	-	-	■	-
		VN-14	1.4	-	-	-	■	-	-	-	■	■
				-	-	-	■	-	-	-	■	■
		VN-20	2.0	-	-	-	-	■	-	-	■	■
				-	-	-	-	■	-	-	■	■
		VN-30	3.0	-	-	-	-	■	-	-	■	■
				-	-	-	-	■	-	-	■	■
	Standard H with integrated vacuum switch											
		VN-05-...-P	0.45	-	-	■	-	-	-	-	■	-
		VN-07-...-P	0.7	-	-	■	-	-	-	-	■	-
VN-10-...-P		0.95	-	-	■	-	-	-	-	■	-	
Inline M												
	VN-05	0.45	■	-	-	-	-	-	-	■	■	
			-	■	-	-	-	-	■	-	■	
			-	-	-	-	-	-	■	-	■	-
			-	-	-	-	-	-	-	■	■	-
	VN-07	0.7	■	-	-	-	-	-	-	-	■	■
			-	■	-	-	-	-	-	-	■	■
			-	-	-	-	-	-	■	-	■	-
			-	-	-	-	-	-	-	■	■	-
	VN-10	0.95	-	-	-	-	-	-	-	■	■	
			-	-	-	-	-	-	-	■	■	
High suction rate	Standard L											
		VN-05	0.45	■	-	-	-	-	-	-	■	■
				-	■	-	-	-	-	-	■	■
		VN-07	0.7	-	■	-	-	-	-	-	■	■
				-	■	-	-	-	-	-	■	■
		VN-10	0.95	-	■	-	■	-	-	-	■	■
				-	-	-	■	-	-	-	■	-
		VN-14	1.4	-	-	-	■	-	-	-	■	■
				-	-	-	■	-	-	-	■	■
		VN-20	2.0	-	-	-	-	■	-	-	■	■
				-	-	-	-	■	-	-	■	■
		VN-30	3.0	-	-	-	-	■	-	-	■	■
				-	-	-	-	■	-	-	■	■
	Standard L with integrated vacuum switch											
		VN-05-...-P	0.45	-	-	■	-	-	-	-	■	-
		VN-07-...-P	0.7	-	-	■	-	-	-	-	■	-
VN-10-...-P		0.95	-	-	■	-	-	-	-	■	-	
Inline N												
	VN-05	0.45	-	■	-	-	-	-	-	■	■	
			-	-	-	-	-	-	■	■	-	

Vacuum generators VN

Product range overview

FESTO

Type	Vacuum port (2)				Exhaust port (3)			Switching function		→ Page
	Push-in connector VQ	Female thread VI	Male thread VA	Push-in sleeve VT	Push-in connector RQ	Female thread RI	Silencer RO	Fixed hysteresis O1	Variable hysteresis O2	
Standard H										
VN-05	■	■	- ■	-	■	■	■	-	-	6 / 1.1-8
VN-07	■	■	- ■	-	■	■	■	-	-	
VN-10	■	■ -	■	-	■	■ -	■	-	-	
VN-14	■	■	■	-	■	■	■	-	-	
VN-20	■	■	■	-	-	-	■	-	-	
VN-30	■	■	■	-	-	-	■	-	-	
Standard H with integrated vacuum switch										
VN-05-...-P	■	-	-	-	-	-	-	■	■	6 / 1.1-25 www.festo.com
VN-07-...-P										
VN-10-...-P										
Inline M										
VN-05	■	■	-	-	■	■	■	-	-	6 / 1.1-8
	■	-	-	■	-	-	-	-	-	
VN-07	■	■	-	-	■	■	■	-	-	
	■	-	-	■	-	-	-	-	-	
VN-10	■	-	-	-	-	-	-	-	-	
Standard L										
VN-05	■	■	- ■	-	■	■	■	-	-	6 / 1.1-8
VN-07	■	■	■	-	■	■	■	-	-	
VN-10	■	■ -	■	-	■	■ -	■	-	-	
VN-14	■	■	■	-	■	■	-	-	-	
VN-20	■	■	■	-	-	-	■	-	-	
VN-30	-	■	■	-	-	-	■	-	-	
Standard L with integrated vacuum switch										
VN-05-...-P	■	-	-	-	-	-	-	■	■	6 / 1.1-25 www.festo.com
VN-07-...-P										
VN-10-...-P										
Inline N										
VN-05	■	■	-	-	■	■	■	-	-	6 / 1.1-8
	■	-	-	■	-	-	-	-	-	

Vacuum generators VN

Type codes

FESTO

VN		05		H		T2		PQ1		VQ1		RQ1	
Type													
VN	Vacuum generator												
Nominal laval nozzle size [mm]													
05	0.45												
07	0.7												
10	0.95												
14	1.4												
20	2.0												
30	3.0												
Ejector characteristic													
H	High vacuum/Standard												
L	High suction rate/Standard												
M	High vacuum/Inline												
N	High suction rate/Inline												
Housing type													
I2	Inline, grid dimensions 10 mm												
I3	Inline, grid dimensions 13 mm												
T2	T-type, grid dimensions 10 mm												
T3	T-type, grid dimensions 14 mm												
T4	T-type, grid dimensions 18 mm												
T6	T-type, grid dimensions 24 mm												
Supply port (1)													
PQ1	Push-in connector QS4												
PQ2	Push-in connector QS6												
PQ4	Push-in connector QS10												
PI2	Female thread M5												
PI4	Female thread G $\frac{1}{8}$												
PI5	Female thread G $\frac{1}{4}$												
Vacuum connection (2)													
VQ1	Push-in connector QS4												
VQ2	Push-in connector QS6												
VQ3	Push-in connector QS8												
VQ5	Push-in connector QS12												
VI2	Female thread M5												
VI4	Female thread G $\frac{1}{8}$												
VI5	Female thread G $\frac{1}{4}$												
VI6	Female thread G $\frac{3}{8}$												
VA4	Male thread G $\frac{1}{8}$												
VA5	Male thread G $\frac{1}{4}$												
VT1	Push-in sleeve \varnothing 4 mm												
VT2	Push-in sleeve \varnothing 6 mm												
Exhaust port (3)													
RQ1	Push-in connector QS4												
RQ2	Push-in connector QS6												
RQ3	Push-in connector QS8												
RI2	Female thread M5												
RI4	Female thread G $\frac{1}{8}$												
RI5	Female thread G $\frac{1}{4}$												
RO1	Silencer, minimal resistance												

 Note

Possible combinations can be found in the ordering data.

Vacuum generators VN

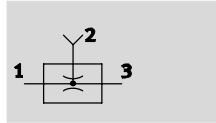

Technical data

Function
VN Standard

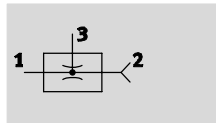

VN Inline



-  - Temperature range
0 ... +60 °C
-  - Operating pressure
1 ... 8 bar

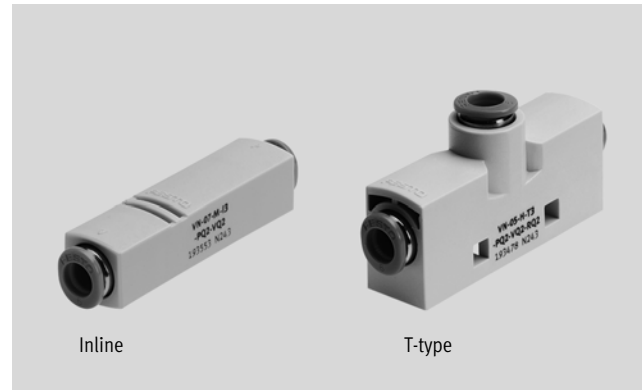

General technical data – Standard										
Design		T-type								
Type		VN-05		VN-07		VN-10		VN-14	VN-20	VN-30
Grid dimension	[mm]	10	14	10	14	14	18	18	24	24
Nominal size of laval nozzle	[mm]	0.45		0.7		0.95		1.4	2.0	3.0
Ejector characteristic		High vacuum H								
		High suction rate L								
Pneumatic connection 1	Push-in connector	QS4	QS6	QS4	QS6	QS6	QS6	QS6	QS10	QS10
	Female thread	M5	G $\frac{1}{8}$	M5	G $\frac{1}{8}$	G $\frac{1}{8}$	–	G $\frac{1}{8}$	G $\frac{1}{4}$	G $\frac{1}{4}$
Vacuum connection	Push-in connector	QS4	QS6	QS4	QS6	QS6	QS8	QS8	QS12	QS12
	Male thread	–	G $\frac{1}{8}$	–	G $\frac{1}{8}$	G $\frac{1}{8}$	G $\frac{1}{4}$	G $\frac{1}{4}$	G $\frac{1}{4}$	G $\frac{1}{4}$
	Female thread	M5	G $\frac{1}{8}$	M5	G $\frac{1}{8}$	G $\frac{1}{8}$	–	G $\frac{1}{4}$	G $\frac{3}{8}$	G $\frac{3}{8}$
Pneumatic connection 3	Push-in connector	QS4	QS6	QS4	QS6	QS6	QS8	QS8	–	–
	Female thread	M5	G $\frac{1}{8}$	M5	G $\frac{1}{8}$	G $\frac{1}{8}$	–	G $\frac{1}{4}$	–	–
	Silencer	min. resis.	min. resis.	min. resis.	min. resis.	min. resis.	min. resis.	min. resis.	min. resis.	min. resis.
Type of mounting		Via through-holes								
		Via H-rail								
		Via wall/surface bracket								
Assembly position		Any								

General technical data – Inline										
Design		T-type				Inline				
Type		VN-05		VN-07		VN-05		VN-07		VN-10
Grid dimension	[mm]	10	14	10	14	10	13	10	13	13
Nominal size of laval nozzle	[mm]	0.45		0.7		0.45		0.7		0.95
Ejector characteristic		High vacuum M								
		High suction rate N				High suction rate N				–
Pneumatic connection 1	Push-in connector	QS4	QS6	QS4	QS6	QS4	QS6	QS4	QS6	QS6
	Female thread	M5	G $\frac{1}{8}$	M5	G $\frac{1}{8}$	–	–	–	–	–
Vacuum connection	Push-in connector	QS4	QS6	QS4	QS6	QS4	QS6	QS4	QS6	QS6
	Female thread	M5	G $\frac{1}{8}$	M5	G $\frac{1}{8}$	–				
	Push-in sleeve	–				4	6	4	6	–
Pneumatic connection 3	Push-in connector	QS4	QS6	QS4	QS6	–				
	Female thread	M5	G $\frac{1}{8}$	M5	G $\frac{1}{8}$	–				
	Silencer	Minimal resistance				–				
Type of mounting		Via through-holes				Inline installation				
		Via H-rail								
		Via wall/surface bracket								
Assembly position		Any								

Vacuum generators VN

Technical data

FESTO

Operating and environmental conditions		
Pneumatic connection	with push-in fitting	without push-in fitting
Operating pressure [bar]	1 ... 8	
Nominal operating pressure [bar]	6	
Operating medium	Dried, filtered and unlubricated compressed air	
Ambient temperature [°C]	0 ... +60	
Temperature of medium [°C]	0 ... +60	
Corrosion resistance class CRC ¹⁾	1	2

- 1) Corrosion resistance class 1 according to Festo standard 940 070
Components requiring low corrosion resistance. Transport and storage protection. Parts that do not have primarily decorative surface requirements, e.g. in internal areas that are not visible or behind covers.
Corrosion resistance class 2 according to Festo standard 940 070
Components requiring moderate corrosion resistance. Externally visible parts with primarily decorative surface requirements which are in direct contact with a normal industrial environment or media such as coolants or lubricating agents.

Performance data – High vacuum										
Ejector characteristic	Standard H							Inline M		
Nominal size of laval nozzle [mm]	0.45	0.7	0.95	1.4	2.0	3.0	0.45	0.7	0.95	
Max. vacuum [%]	88	88	89	88	92	93	86	86	86	
Operating pressure for max. vacuum [bar]	4.5	4.7	4.5	5.0	3.5	3.7	6.0	5.8	5.8	
Max. suction rate with respect to atmosphere [l/min]	6.2	16	25	51.6	98	186	6.1	13.5	28	
Operating pressure for max. suction rate [bar]	2.1	2.1	3.1	5.1	2.0	5.0	6.3	7.0	5.0	
Pressurisation time for 1 l volume at p ₁ = 6 bar [s]	4.8	1.9	1.1	0.5	0.2	0.1	4.7	2.1	0.96	

Performance data – High suction rate								
Ejector characteristic	Standard L						Inline N	
Nominal size of laval nozzle [mm]	0.45	0.7	0.95	1.4	2.0	3.0	0.45	
Max. suction rate with respect to atmosphere [l/min]	15.7	38.8	62.7	90.0	188.0	339.0	12.0	
Operating pressure for max. suction rate [bar]	5.0	6.2	4.0	8.0	3.0	6.0	6.0	
Pressurisation time for 1 l volume at p ₁ = 6 bar [s]	1.7	0.5	0.46	0.25	0.15	0.1	1.57	

Vacuum generators VN

Technical data

Materials

Sectional view

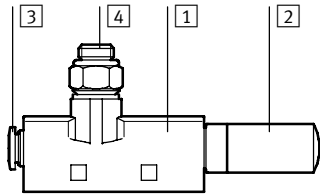

Vacuum generator VN-05/07/10/14

1	Housing	Polyacetate, reinforced
2	Silencer	Polyethylene
3	Push-in fitting	Plastic, nickel plated brass
4	Connecting thread	Wrought aluminium alloy
-	Seals	Nitrile rubber
Note on materials		Free of copper and PTFE Free of paint wetting impairment substances

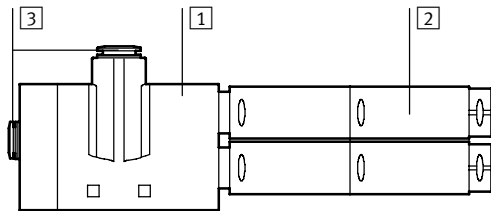

Vacuum generator VN-20/30

1	Housing	Polyacetate, reinforced
2	Silencer	Wrought aluminium alloy, polyacetate, PU foam
3	Push-in fitting	Plastic, nickel plated brass
-	Connecting thread	Wrought aluminium alloy
-	Seals	Nitrile rubber
Note on materials		Free of copper and PTFE Free of paint wetting impairment substances

Vacuum p_u as a function of operating pressure p_1

High vacuum

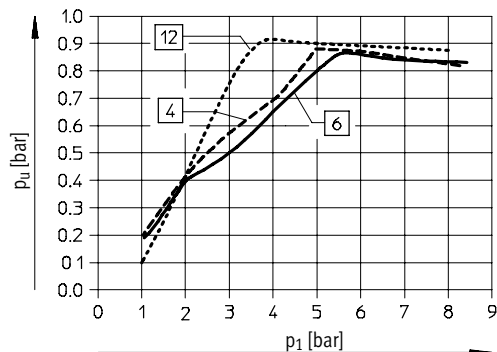
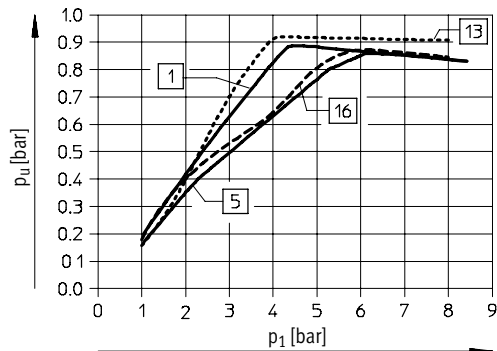

High suction rate

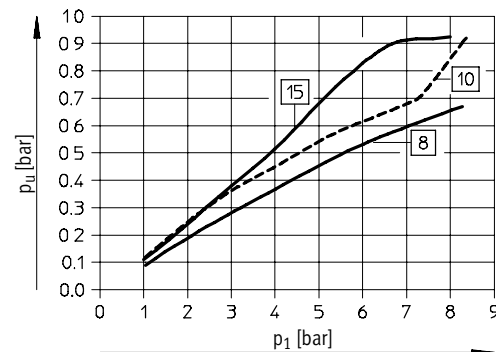
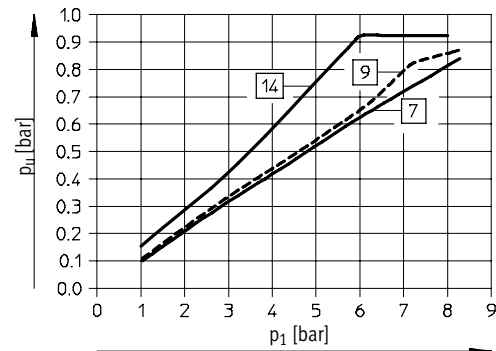

Standard:

- 1 VN-05-H-...
- VN-07-H-...
- VN-10-H-...
- 4 VN-14-H-...
- 12 VN-20-H-...
- 13 VN-30-H-...

Inline:

- 5 VN-05-M-...
- 6 VN-07-M-...
- 16 VN-10-M-...

Standard:

- 7 VN-05-L-...
- 8 VN-07-L-...
- 9 VN-10-L-...
- 10 VN-14-L-...
- 14 VN-20-L-...
- 15 VN-30-L-...

Inline:

- 8 VN-05-N-...

Vacuum generators VN

Technical data

Evacuation time t as a function of vacuum p_u for 1 l volume at 6 bar operating pressure

High vacuum

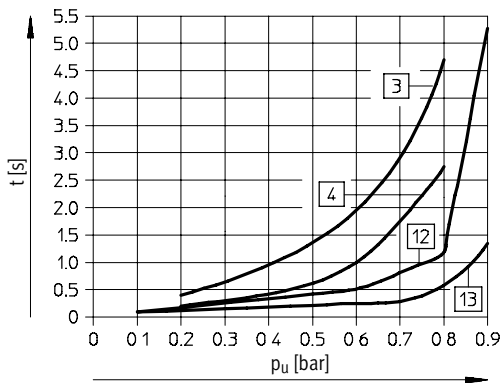
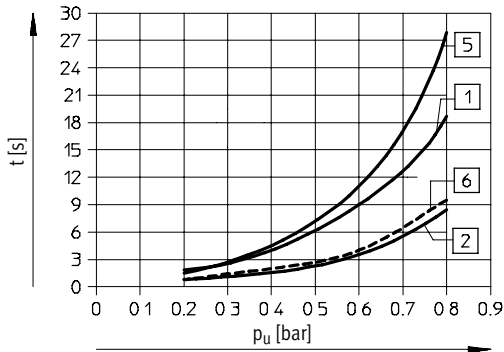

Standard:

- 1 VN-05-H-...
- 2 VN-07-H-...
- 3 VN-10-H-...
- 4 VN-14-H-...
- 12 VN-20-H-...
- 13 VN-30-H-...

Inline:

- 5 VN-05-M-...
- 6 VN-07-M-...
- 3 VN-10-M-...

High suction rate

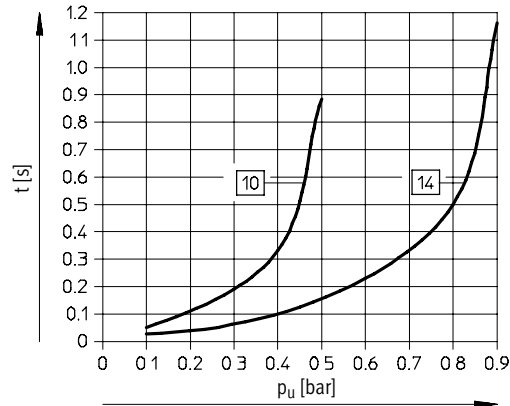
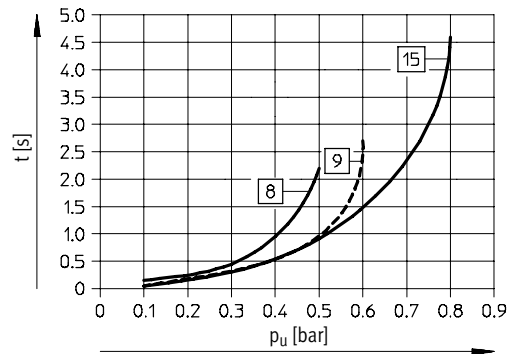
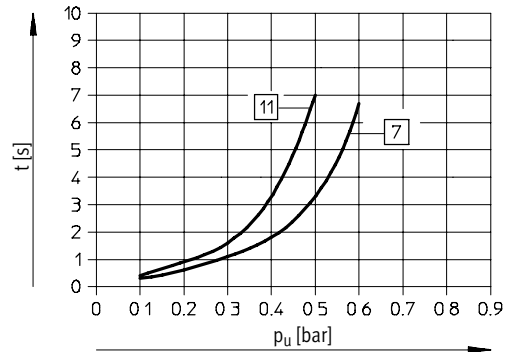

Standard:

- 7 VN-05-L-...
- 8 VN-07-L-...
- 9 VN-10-L-...
- 10 VN-14-L-...
- 14 VN-20-L-...
- 15 VN-30-L-...

Inline:

- 11 VN-05-N-...

Vacuum generators VN

Technical data

Suction rate q_{ns} (with respect to atmosphere) as a function of operating pressure p_1

High vacuum

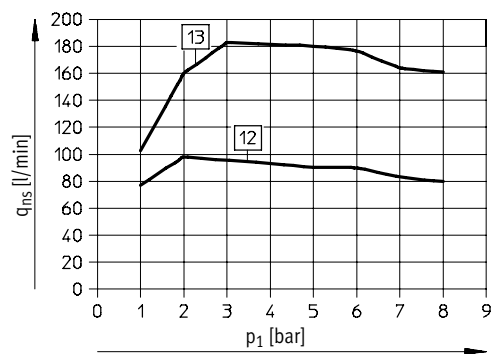
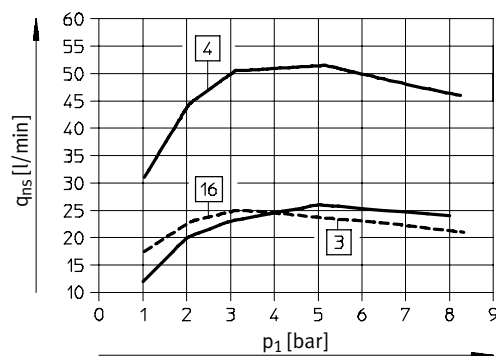
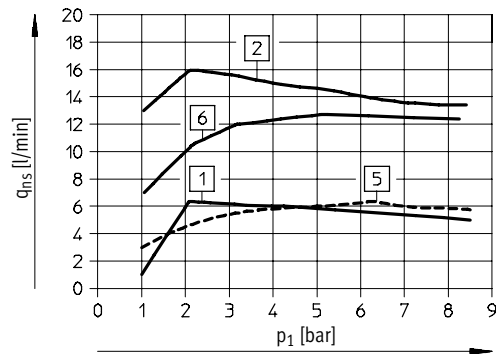

High suction rate

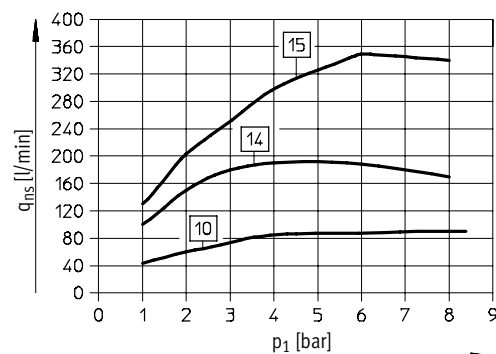
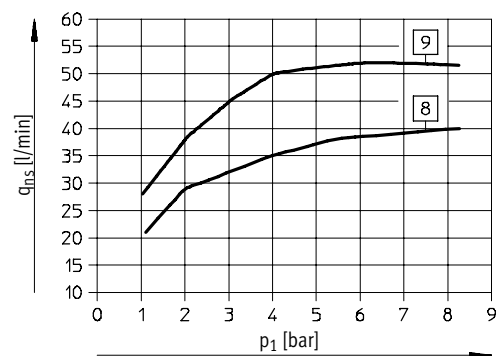
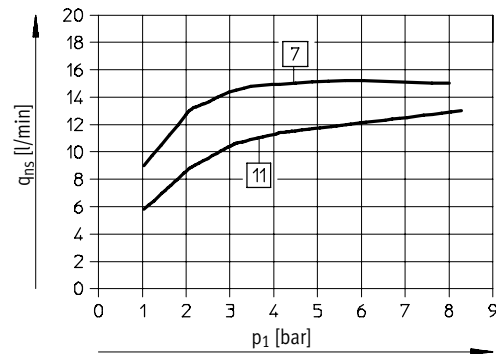

Standard:

- 1 VN-05-H-...
- 2 VN-07-H-...
- 3 VN-10-H-...
- 4 VN-14-H-...
- 12 VN-20-H-...
- 13 VN-30-H-...

Inline:

- 5 VN-05-M-...
- 6 VN-07-M-...
- 16 VN-10-M-...

Standard:

- 7 VN-05-L-...
- 8 VN-07-L-...
- 9 VN-10-L-...
- 10 VN-14-L-...
- 14 VN-20-L-...
- 15 VN-30-L-...

Inline:

- 11 VN-05-N-...

Vacuum generators VN

Technical data

Noise level L_p (at distance of 1 m) as a function of operating pressure p_1

High vacuum

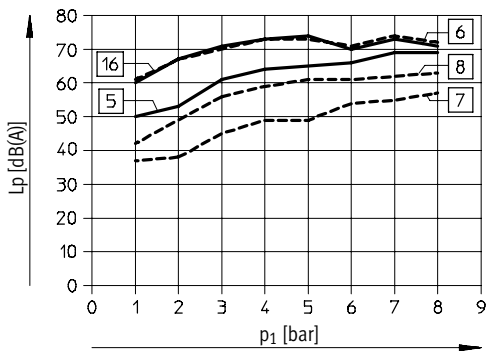
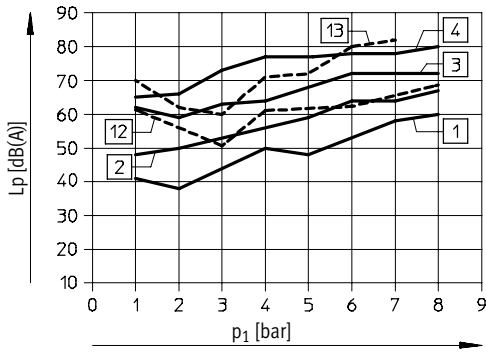

Standard:

- 1 VN-05-H-...-R01
- 2 VN-07-H-...-R01
- 3 VN-10-H-...-R01
- 4 VN-14-H-...-R01
- 12 VN-20-H-...-R01
- 13 VN-30-H-...-R01

Inline:

- T-type
- 7 VN-05-M-...-R01
- 8 VN-07-M-...-R01
- 16 VN-10-M-...-R01

Inline

- 5 VN-05-M-I3-...
- 6 VN-07-M-I3-...

High suction rate

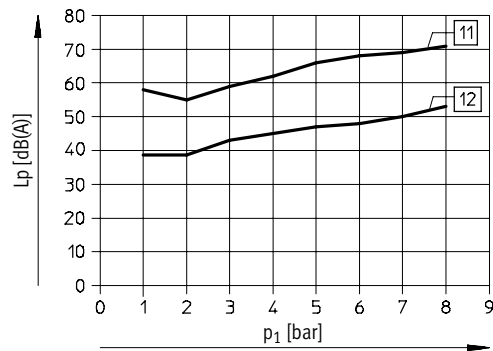
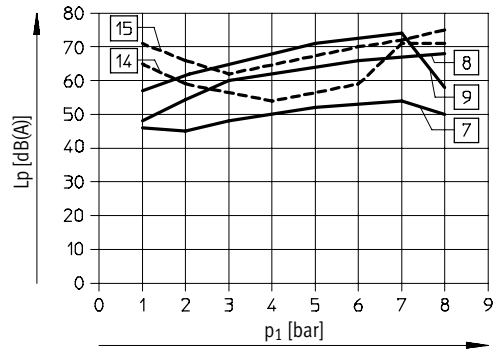

Standard:

- 7 VN-05-L-...-R01
- 8 VN-07-L-...-R01
- 9 VN-10-L-...-R01
- 14 VN-20-L-...-R01
- 15 VN-30-L-...-R01

Inline:

- T-type
- 12 VN-05-N-...-R01
- Inline
- 11 VN-05-N-I3-...

Vacuum generators VN

Technical data

Air consumption q_n as a function of operating pressure p_1 High vacuum/high suction rate

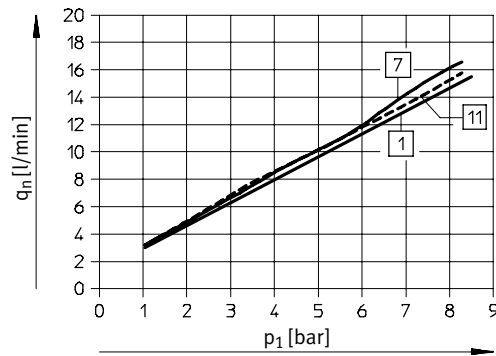

Standard:

- 1 VN-05-H...
- 7 VN-05-L...

Inline:

- 1 VN-05-M...
- 11 VN-05-N...

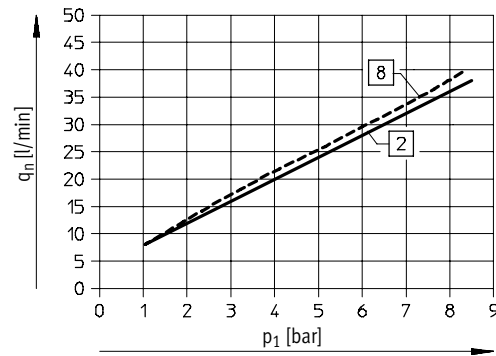

Standard:

- 2 VN-07-H...
- 8 VN-07-L...

Inline:

- 2 VN-07-M...

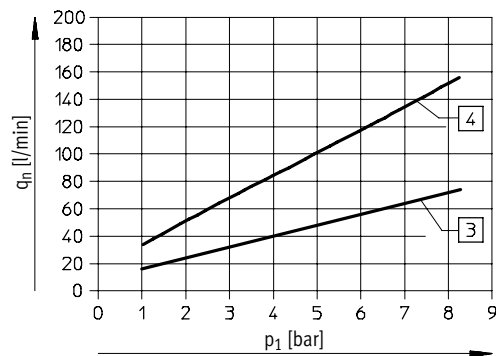

Standard:

- 3 VN-10-H...
- VN-10-L...
- 4 VN-14-H...
- VN-14-L...

Inline:

- 3 VN-10-M...

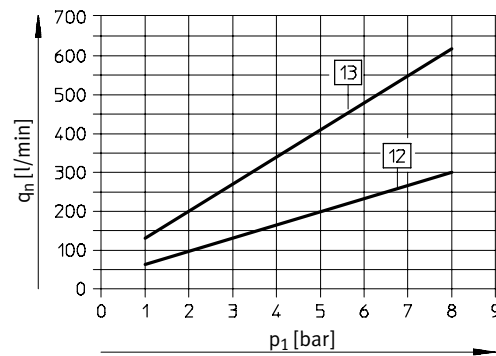

Standard:

- 12 VN-20-H...
- VN-20-L...
- 13 VN-30-H...
- VN-30-L...

Vacuum generators VN

Technical data

Efficiency η as a function of vacuum p_u at 6 bar operating pressure

High vacuum/high suction rate

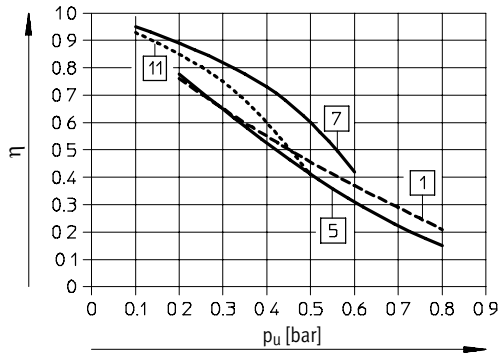

Standard:

- 1 VN-05-H...
- 7 VN-05-L...

Inline:

- 5 VN-05-M...
- 11 VN-05-N...

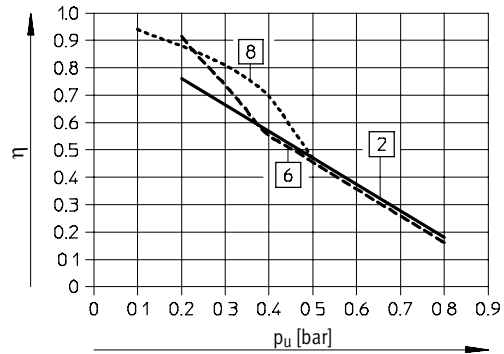

Standard:

- 2 VN-07-H...
- 8 VN-07-L...

Inline:

- 6 VN-07-M...

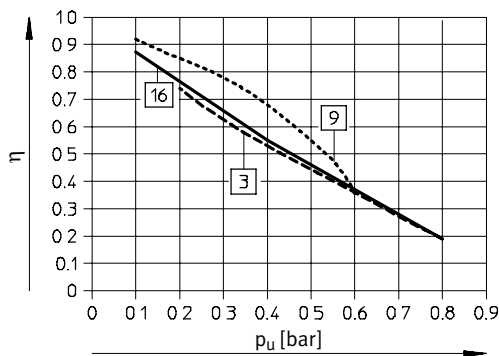

Standard:

- 3 VN-10-H...
- 9 VN-10-L...

Inline:

- 16 VN-10-M...

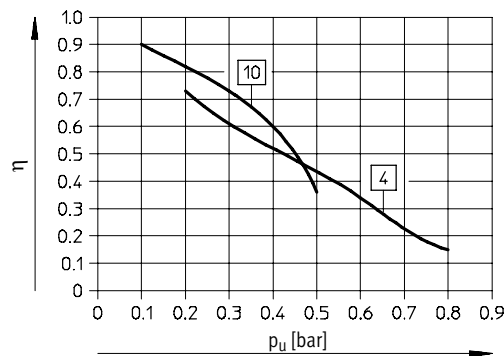

Standard:

- 4 VN-14-H...
- 10 VN-14-L...

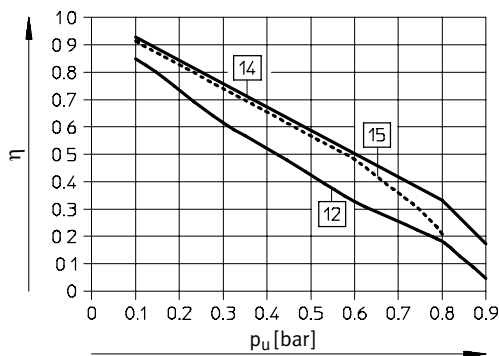

Standard:

- 12 VN-20-H...
- VN-30-H...
- 14 VN-20-L...
- 15 VN-30-L...

Vacuum generators VN

Technical data

FESTO

Dimensions – T-type/Standard, VN-05/07/10/14

Download CAD data → www.festo.com/en/engineering

VN-...-T...-PQ...-VQ...-RQ...

VN-...-T...-PQ...-VQ...-R01

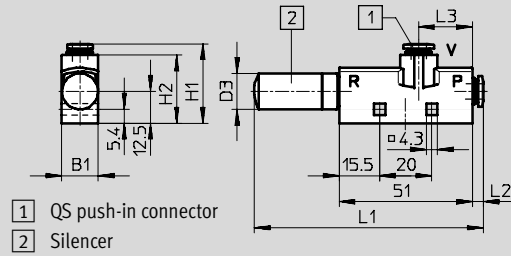
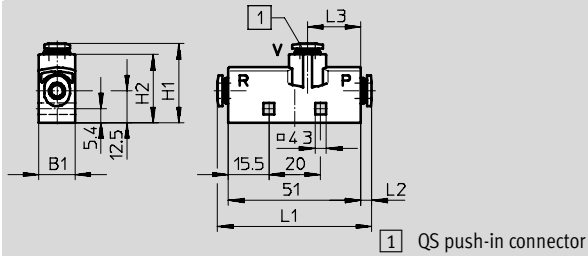

VN-...-T...-PQ...-VA...-RQ...

VN-...-T...-PQ...-VA...-R01

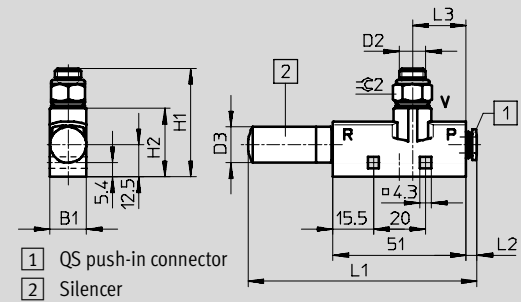
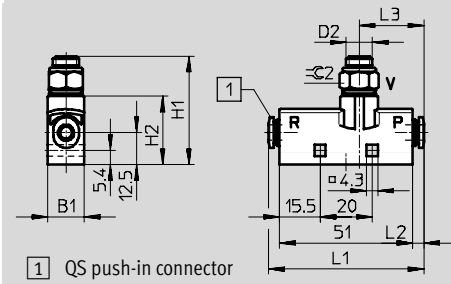

VN-...-T...-PI...-VI...-RI...

VN-...-T...-PI...-VI...-R01

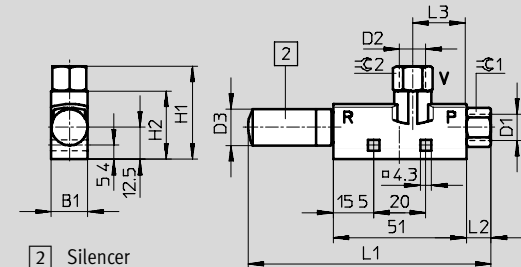
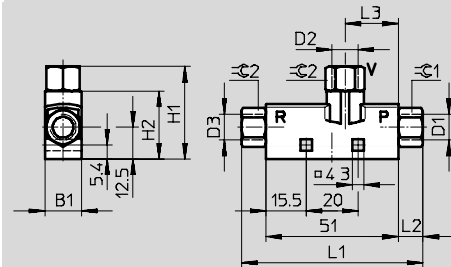

Type	B1	Connections			H1	H2	L1	L2	L3	⌀C1	⌀C2
		P D1	V D2	R D3							
VN-...-T2-PQ1-VQ1-RQ1	10	QS4	QS4	QS4	31.3	27.7	58.2	3.6	24.3	-	-
VN-...-T2-PQ1-VQ1-R01				9.8 ¹⁾							
VN-...-T2-PI2-VI2-RI2		M5	M5	M5	32.7		61	5	9	9	
VN-...-T2-PI2-VI2-R01				9.8 ¹⁾							
VN-...-T3-PQ2-VQ2-RQ2	14	QS6	QS6	QS6	30.4	26.2	59.4	4.2	25.5	-	-
VN-...-T3-PQ2-VQ2-R01				13.8 ¹⁾							
VN-...-T3-PQ2-VA4-RQ2			G ¹ / ₈	G ¹ / ₈	QS6		41.5	59.4	9.5	13	13
VN-...-T3-PQ2-VA4-R01					13.8 ¹⁾						
VN-...-T3-PI4-VI4-RI4		G ¹ / ₈	G ¹ / ₈	G ¹ / ₈	35.7	70	9.5	13	13		
VN-...-T3-PI4-VI4-R01				13.8 ¹⁾							
VN-...-T4-PQ2-VQ3-RQ3	18	QS6	QS8	QS8	35.9	30.7	63.8	4.2	25.5	-	-
VN-...-T4-PQ2-VQ3-R01				17.8 ¹⁾							
VN-...-T4-PQ2-VA5-RQ3			G ¹ / ₄	G ¹ / ₄	QS8		50.5	63.8	9.5	13	17
VN-...-T4-PQ2-VA5-R01					17.8 ¹⁾						
VN-...-T4-PI4-VI5-RI5		G ¹ / ₈	G ¹ / ₈	G ¹ / ₄	48.15	81.4	9.5	13	17		
VN-...-T4-PI4-VI5-R01				17.8 ¹⁾							

1) Ø Silencer

Vacuum generators VN

Technical data

Dimensions – T-type/Inline, VN-05/07

Download CAD data → www.festo.com/en/engineering

VN-...-T...-PQ...-VQ...-RQ...

VN-...-T...-PQ...-VQ...-R01

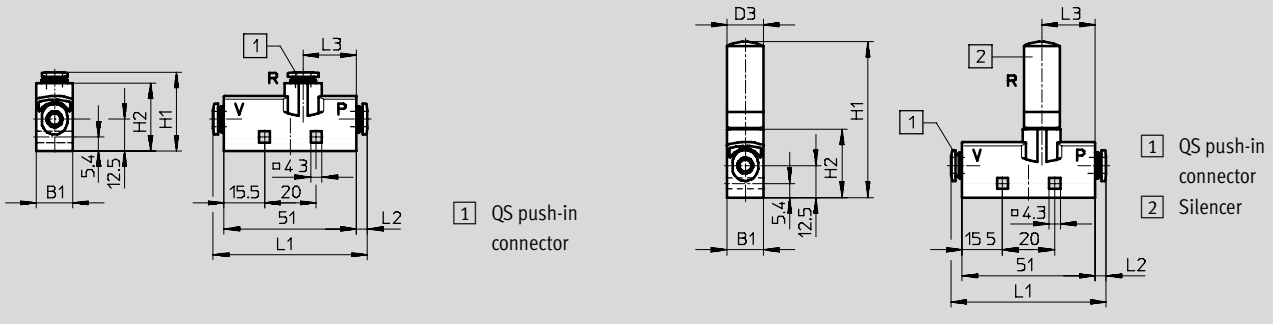

VN-...-T...-PI...-VI...-RI...

VN-...-T...-PI...-VI...-R01

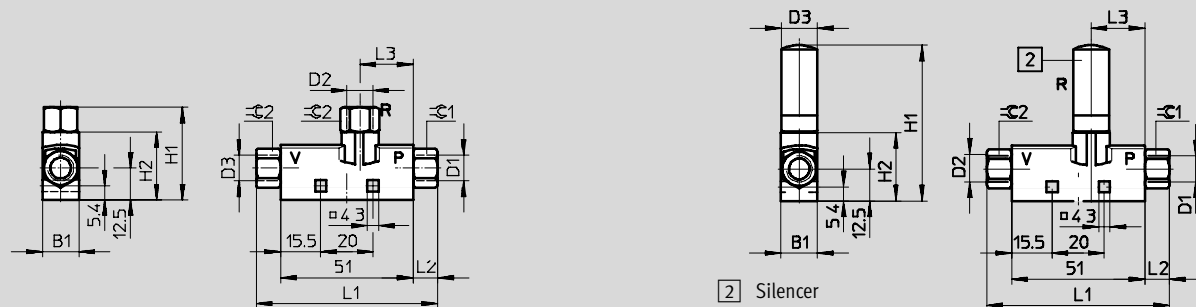

Type	B1	Connections			H1	H2	L1	L2	L3	∅C1	∅C2
		P D1	V D2	R D3							
VN-...-T2-PQ1-VQ1-RQ1	10	QS4	QS4	QS4	31.3	27.7	58.2	3.6	24.3	-	-
VN-...-T2-PQ1-VQ1-R01				9.8 ¹⁾	59.9						
VN-...-T2-PI2-VI2-RI2		M5	M5	M5	32.7						
VN-...-T2-PI2-VI2-R01				9.8 ¹⁾	59.9						
VN-...-T3-PQ2-VQ2-RQ2	14	QS6	QS6	QS6	30.4	26.2	59.4	4.2	25.5	-	-
VN-...-T3-PQ2-VQ2-R01				13.8 ¹⁾	68.6						
VN-...-T3-PI4-VI4-RI4		G ³ / ₈	G ³ / ₈	G ³ / ₈	35.7						
VN-...-T3-PI4-VI4-R01				13.8 ¹⁾	68.6						

1) ∅Silencer

Dimensions – Inline, VN-05/07/10

Download CAD data → www.festo.com/en/engineering

VN-05/07-...-I...-PQ...-VQ...

VN-10-M-I3-PQ2-VQ2

VN-05/07-...-I...-PQ...-VT...

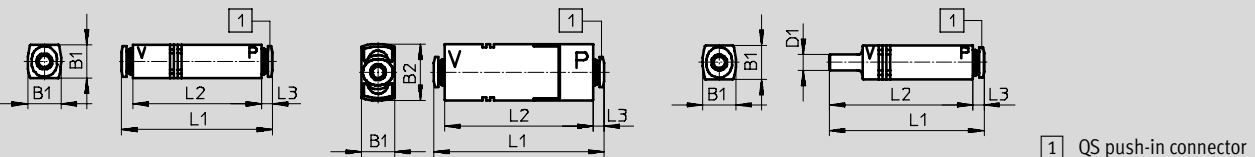





Type	B1	B2	Connections		D1 ∅	L1	L2	L3
			P	V				
VN-05/07-...-I2-PQ1-VQ1	10	-	QS4	QS4	-	57.4	50.2	3.6
VN-05/07-...-I2-PQ1-VT1				-	4	61.6	58	

VN-05/07-...-I3-PQ2-VQ2	13	-	QS6	QS6	-	58.6	50.2	4.2
VN-10-M-I3-PQ2-VQ2		22				66.1	57.7	
VN-05/07-...-I3-PQ2-VT2		-				60.2	56	

Vacuum generators VN

FESTO

Technical data

Ordering data and weights – Standard								
T-type								
Housing width [mm]	Nominal size [mm]	Weight [g]	High vacuum H			Weight [g]	High suction rate L	
			Part No.	Type			Part No.	Type
with push-in connector								
10	0.45	15.1	526 100	VN-05-H-T2-PQ1-VQ1-RQ1		15.1	526 114	VN-05-L-T2-PQ1-VQ1-RQ1
	0.7	15.4	526 101	VN-07-H-T2-PQ1-VQ1-RQ1		–	–	–
14	0.45	22	193 478	VN-05-H-T3-PQ2-VQ2-RQ2		22	193 561	VN-05-L-T3-PQ2-VQ2-RQ2
	0.7	22	193 479	VN-07-H-T3-PQ2-VQ2-RQ2		22	193 562	VN-07-L-T3-PQ2-VQ2-RQ2
	0.95	22	193 480	VN-10-H-T3-PQ2-VQ2-RQ2		22	193 563	VN-10-L-T3-PQ2-VQ2-RQ2
18	0.95	26.9	526 147	VN-10-H-T4-PQ2-VQ3-RQ3		26.4	526 157	VN-10-L-T4-PQ2-VQ3-RQ3
	1.4	27	193 482	VN-14-H-T4-PQ2-VQ3-RQ3		27	193 565	VN-14-L-T4-PQ2-VQ3-RQ3
with push-in connector and silencer								
10	0.45	14.3	193 569	VN-05-H-T2-PQ1-VQ1-R01		14.3	193 595	VN-05-L-T2-PQ1-VQ1-R01
	0.7	14.6	193 570	VN-07-H-T2-PQ1-VQ1-R01		–	–	–
14	0.45	23	193 488	VN-05-H-T3-PQ2-VQ2-R01		22.8	193 571	VN-05-L-T3-PQ2-VQ2-R01
	0.7	23	193 489	VN-07-H-T3-PQ2-VQ2-R01		23.1	193 572	VN-07-L-T3-PQ2-VQ2-R01
	0.95	23	193 490	VN-10-H-T3-PQ2-VQ2-R01		23.3	193 573	VN-10-L-T3-PQ2-VQ2-R01
18	0.95	28.4	526 149	VN-10-H-T4-PQ2-VQ3-R01		25.2	526 159	VN-10-L-T4-PQ2-VQ3-R01
	1.4	29	193 492	VN-14-H-T4-PQ2-VQ3-R01		–	–	–
24	2.0	182	193 495	VN-20-H-T6-PQ4-VQ5-R01		182	193 578	VN-20-L-T6-PQ4-VQ5-R01
	3.0	182	193 497	VN-30-H-T6-PQ4-VQ5-R01		–	–	–
with push-in connector, vacuum connection with male thread								
14	0.45	24	193 516	VN-05-H-T3-PQ2-VA4-RQ2		24	193 599	VN-05-L-T3-PQ2-VA4-RQ2
	0.7	23	193 517	VN-07-H-T3-PQ2-VA4-RQ2		24	193 600	VN-07-L-T3-PQ2-VA4-RQ2
	0.95	24	193 518	VN-10-H-T3-PQ2-VA4-RQ2		24	193 601	VN-10-L-T3-PQ2-VA4-RQ2
18	0.95	32.5	526 153	VN-10-H-T4-PQ2-VA5-RQ3		32.5	526 163	VN-10-L-T4-PQ2-VA5-RQ3
	1.4	33	193 520	VN-14-H-T4-PQ2-VA5-RQ3		33	193 603	VN-14-L-T4-PQ2-VA5-RQ3
with push-in connector, vacuum connection with male thread and silencer								
14	0.45	24	193 526	VN-05-H-T3-PQ2-VA4-R01		24.5	193 609	VN-05-L-T3-PQ2-VA4-R01
	0.7	25	193 527	VN-07-H-T3-PQ2-VA4-R01		24.8	193 610	VN-07-L-T3-PQ2-VA4-R01
	0.95	25	193 528	VN-10-H-T3-PQ2-VA4-R01		25	193 611	VN-10-L-T3-PQ2-VA4-R01
18	0.95	34	526 155	VN-10-H-T4-PQ2-VA5-R01		34	526 165	VN-10-L-T4-PQ2-VA5-R01
	1.4	34	193 530	VN-14-H-T4-PQ2-VA5-R01		–	–	–
24	2.0	189	526 145	VN-20-H-T6-PQ4-VA5-R01		189	526 135	VN-20-L-T6-PQ4-VA5-R01
	3.0	189	526 146	VN-30-H-T6-PQ4-VA5-R01		189	526 136	VN-30-L-T6-PQ4-VA5-R01

 Core Range

Vacuum generators VN

Technical data

Ordering data and weights – Standard							
T-type							
Housing width [mm]	Nominal size [mm]	Weight [g]	High vacuum H		Weight [g]	High suction rate L	
			Part No.	Type		Part No.	Type
with female thread							
10	0.45	12.9	526 102	VN-05-H-T2-PI2-VI2-RI2	13	526 116	VN-05-L-T2-PI2-VI2-RI2
	0.7	13.2	526 103	VN-07-H-T2-PI2-VI2-RI2	–	–	–
14	0.45	21	193 498	VN-05-H-T3-PI4-VI4-RI4	21	193 581	VN-05-L-T3-PI4-VI4-RI4
	0.7	21	193 499	VN-07-H-T3-PI4-VI4-RI4	21	193 582	VN-07-L-T3-PI4-VI4-RI4
	0.95	22	193 500	VN-10-H-T3-PI4-VI4-RI4	22	193 583	VN-10-L-T3-PI4-VI4-RI4
18	1.4	36	193 502	VN-14-H-T4-PI4-VI5-RI5	36	193 585	VN-14-L-T4-PI4-VI5-RI5
with female thread and silencer							
10	0.45	12.9	526 104	VN-05-H-T2-PI2-VI2-RO1	12.9	526 118	VN-05-L-T2-PI2-VI2-RO1
	0.7	13.2	526 105	VN-07-H-T2-PI2-VI2-RO1	–	–	–
14	0.45	22	193 507	VN-05-H-T3-PI4-VI4-RO1	22.3	193 590	VN-05-L-T3-PI4-VI4-RO1
	0.7	23	193 508	VN-07-H-T3-PI4-VI4-RO1	22.6	193 591	VN-07-L-T3-PI4-VI4-RO1
	0.95	23	193 509	VN-10-H-T3-PI4-VI4-RO1	22.8	193 592	VN-10-L-T3-PI4-VI4-RO1
18	1.4	34	193 511	VN-14-H-T4-PI4-VI5-RO1	–	–	–
24	2.0	183	526 141	VN-20-H-T6-PI5-VI6-RO1	183	526 131	VN-20-L-T6-PI5-VI6-RO1
	3.0	183	526 142	VN-30-H-T6-PI5-VI6-RO1	183	526 132	VN-30-L-T6-PI5-VI6-RO1

Ordering data and weights – Inline							
T-type							
Housing width [mm]	Nominal size [mm]	Weight [g]	High vacuum M		Weight [g]	High suction rate N	
			Part No.	Type		Part No.	Type
with push-in connector							
10	0.45	14.5	526 106	VN-05-M-T2-PQ1-VQ1-RQ1	–	–	–
	0.7	15.4	526 107	VN-07-M-T2-PQ1-VQ1-RQ1	–	–	–
14	0.45	21	193 536	VN-05-M-T3-PQ2-VQ2-RQ2	22	193 619	VN-05-N-T3-PQ2-VQ2-RQ2
	0.7	22	193 537	VN-07-M-T3-PQ2-VQ2-RQ2	–	–	–
with push-in connector and silencer							
10	0.45	13.7	526 108	VN-05-M-T2-PQ1-VQ1-RO1	–	–	–
	0.7	14.6	526 109	VN-07-M-T2-PQ1-VQ1-RO1	–	–	–
14	0.45	22	193 540	VN-05-M-T3-PQ2-VQ2-RO1	22.8	193 623	VN-05-N-T3-PQ2-VQ2-RO1
	0.7	23	193 541	VN-07-M-T3-PQ2-VQ2-RO1	–	–	–
with female thread							
10	0.45	12.4	526 110	VN-05-M-T2-PI2-VI2-RI2	–	–	–
	0.7	13.3	526 111	VN-07-M-T2-PI2-VI2-RI2	–	–	–
14	0.45	21	193 544	VN-05-M-T3-PI4-VI4-RI4	21	193 627	VN-05-N-T3-PI4-VI4-RI4
	0.7	21	193 545	VN-07-M-T3-PI4-VI4-RI4	–	–	–
with female thread and silencer							
10	0.45	12.3	526 112	VN-05-M-T2-PI2-VI2-RO1	–	–	–
	0.7	13.2	526 113	VN-07-M-T2-PI2-VI2-RO1	–	–	–
14	0.45	22	193 548	VN-05-M-T3-PI4-VI4-RO1	22.3	193 631	VN-05-N-T3-PI4-VI4-RO1
	0.7	22	193 549	VN-07-M-T3-PI4-VI4-RO1	–	–	–

Vacuum generators VN

FESTO

Technical data

Ordering data and weights – Inline							
Inline							
Housing width [mm]	Nominal size [mm]	Weight [g]	High vacuum H		Weight [g]	High suction rate L	
			Part No.	Type		Part No.	Type
with push-in connector							
10	0.45	10.2	193 580	VN-05-M-I2-PQ1-VQ1	-	-	-
	0.7	10.5	193 586	VN-07-M-I2-PQ1-VQ1			
13	0.45	15	193 552	VN-05-M-I3-PQ2-VQ2	16	193 635	VN-05-N-I3-PQ2-VQ2
	0.7	16	193 553	VN-07-M-I3-PQ2-VQ2			
	0.95	23.5	193 554	VN-10-M-I3-PQ2-VQ2			
with push-in connector and push-in sleeve							
10	0.45	7.1	193 587	VN-05-M-I2-PQ1-VT1	-	-	-
	0.7	8	193 588	VN-07-M-I2-PQ1-VT1			
13	0.45	12	193 555	VN-05-M-I3-PQ2-VT2	12	193 637	VN-05-N-I3-PQ2-VT2
	0.7	13	193 556	VN-07-M-I3-PQ2-VT2			

 Note

Accessories:

Mounting plate VN-... suitable for
H-rail 35x7.5 to DIN EN 50 022

→ NO TAG

Silencer UO/UOM

Silencer kit UOMS

→ NO TAG

 Core Range

Vacuum generators VN, with integrated vacuum switch

Type codes

		VN	-	05	-	H	-	T4	-	PQ2	-	VQ2	-	O2	-	P
Type																
VN	Vacuum generator															
Nominal size [mm]																
05	0.45															
07	0.7															
10	0.95															
Ejector characteristic																
H	High vacuum/Standard															
L	High suction rate/Standard															
Housing type																
T4	T-type, grid dimensions 16 mm															
Supply port (1)																
PQ2	Push-in connector QS6															
Vacuum connection (2)																
VQ2	Push-in connector QS6															
Switching function																
O1	Threshold value with fixed hysteresis, 2 teach-in points, NO contact															
O2	Threshold value with variable hysteresis, NO contact															
Electrical output																
P	Switch output PNP															

Vacuum generators VN, with integrated vacuum switch

Technical data

Function
VN Standard

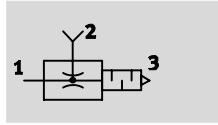

 Temperature range
0 ... +60 °C

 Operating pressure
1 ... 8 bar



■ Threshold value comparator with fixed or variable hysteresis

■ Teach-in setting option for threshold value and hysteresis

General technical data			
Design	T-type		
Type	VN-05	VN-07	VN-10
Grid dimension [mm]	16	16	16
Nominal size [mm]	0.45	0.7	0.95
Ejector characteristic	High vacuum/Standard H High suction rate/Standard L		
Pneumatic connection 1	QS6		
Vacuum connection	QS6		
Pneumatic connection 3	Silencer, minimal resistance		
Measuring principle	Piezoresistive		
Measured variable	Relative pressure		
Pressure measuring range [bar]	-1 ... 0		
Type of mounting	Via through-holes		
Assembly position	Any ¹⁾		
Cleaning recommendation	Soap suds		
Product weight [g]	33	36	36

1) The collection of condensate in the sensor should be prevented.

Operating and environmental conditions	
Operating pressure [bar]	1 ... 8
Nominal operating pressure [bar]	6
Operating medium	Dried, filtered and unlubricated compressed air
Ambient temperature [°C]	0 ... +50
Temperature of medium [°C]	0 ... +60
Corrosion resistance class CRC ¹⁾	1

1) Corrosion resistance class 1 according to Festo standard 940 070
Components requiring low corrosion resistance. Transport and storage protection. Parts that do not have primarily decorative surface requirements, e.g. in internal areas that are not visible or behind covers.

Performance data							
Ejector characteristic		High vacuum/Standard H			High suction rate/Standard L		
		Nominal size [mm]	0.45	0.7	0.95	0.45	0.7
Max. vacuum [%]		92	92	93	-	-	-
Operating pressure for max. vacuum [bar]		4.9	4.4	3.5	-	-	-
Max. suction rate with respect to atmosphere [l/min]		7.2	16.2	21.8	13.6	30.9	41.5
Operating pressure for max. suction rate [bar]		3	3	3	5	4	5

Vacuum generators VN, with integrated vacuum switch

Technical data

Electrical data		
Operating voltage range	[V DC]	15 ... 30
Residual ripple	[%]	10
Electrical connection		M8x1, 3-pin
Switch-on/switch-off times	[ms]	≤ 4
Switch output		PNP
Max. output current	[mA]	100
Residual current	[mA]	≤ 0.3
Voltage drop	[V]	≤ 1.5
Switching element function		NO contact
Switching function		Threshold value comparator with fixed hysteresis Threshold value comparator with variable hysteresis
Threshold value setting range	[bar]	-1 ... 0
Accuracy	[% FS] ¹⁾	1.5
Hysteresis	[% FS] ¹⁾	2 (threshold value comparator with fixed hysteresis)
Long-term drift	[% FS] ¹⁾	Max. ±0.5
Temperature coefficient of switching point	[%/K]	0.05
Type of display/switching status display		LED
Inductive protective circuit		Adapted to MZ, MY, ME coils
Protection against short circuit		Pulsed
Protection against polarity reversal		For all electrical connections
Protection against overloading		Yes
Protection class		IP40 (to EN 60 529)
CE symbol		EU conformity in accordance with the directive 89/336/EEC (EMC)

1) % FS = % of the measuring range final value (full scale)

Electrical outputs¹⁾ Pin allocations

1 switch output PNP

Plug M8x1

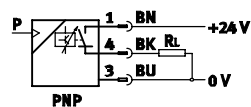

1 = +24 V
3 = 0 V
4 = Output A



1) Core colours indicated apply when using plug sockets with cable SIM-M8-3... → NO TAG

Materials

General view

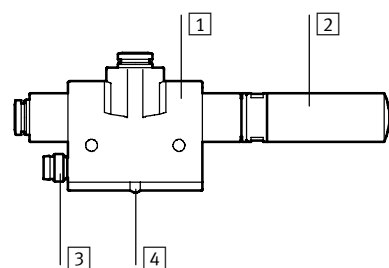

Vacuum generator	
1	Housing Polyacetate, reinforced
2	Silencer Polyethylene
3	Plug housing Polyamide, nickel and chrome plated brass
4	Fibre optics Polycarbonate
-	Key pad Silicone rubber
-	Seals Nitrile rubber
	Note on materials Contains paint-wetting impairment substances

Vacuum generators VN, with integrated vacuum switch

Technical data

Vacuum p_u as a function of operating pressure p_1

High vacuum/high suction rate

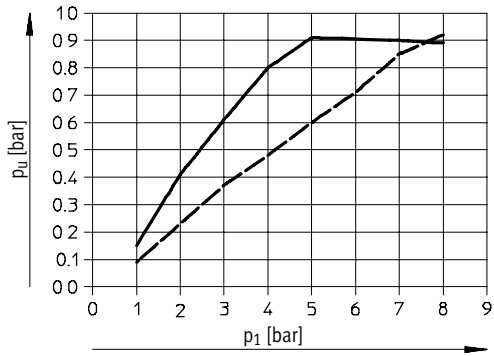

— VN-05-H
- - - VN-05-L

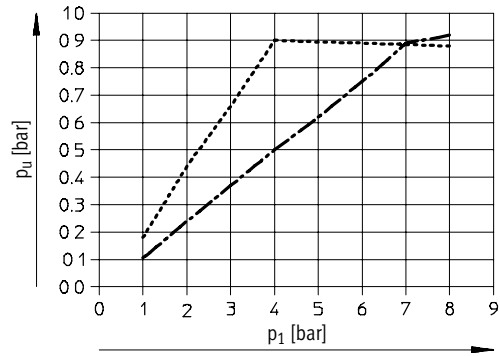

..... VN-07-H
- · - · - VN-07-L

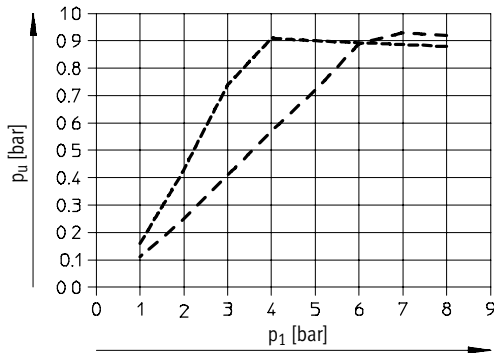

----- VN-10-H
- · - · - VN-10-L

Evacuation time t as a function of vacuum p_u for 1 l volume at 6 bar operating pressure

High vacuum/high suction rate

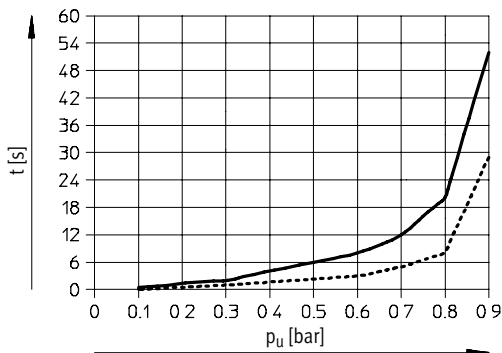

— VN-05-H
..... VN-07-H

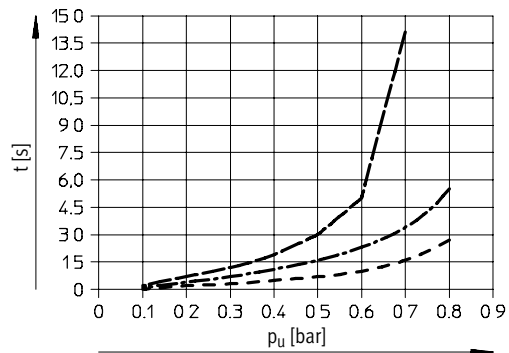

----- VN-05-L
- · - · - VN-07-L
----- VN-10-H
- · - · - VN-10-L

Vacuum generators VN, with integrated vacuum switch

Technical data

Suction rate q_{ns} (with respect to atmosphere) as a function of operating pressure p_1

High vacuum/high suction rate

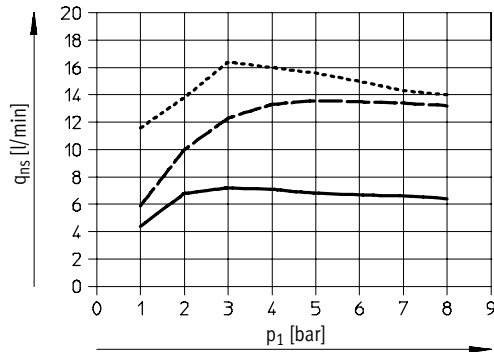

- VN-05-H
- - - VN-05-L
- VN-07-H

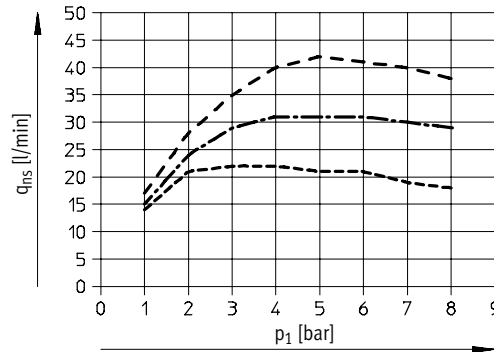

- · - · - VN-07-L
- - - VN-10-H
- VN-10-L

Air consumption q_n as a function of operating pressure p_1

High vacuum/high suction rate

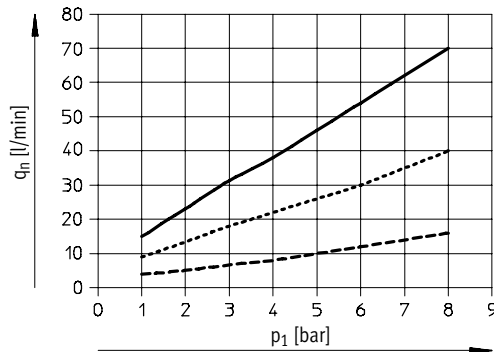

- VN-05
- VN-07
- - - VN-10

Vacuum generators VN, with integrated vacuum switch

Technical data

Dimensions

Download CAD data → www.festo.com/en/engineering

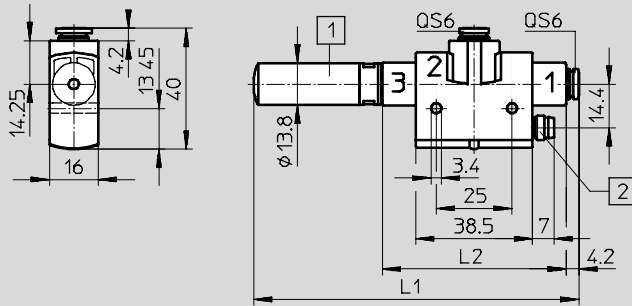

- 1 Silencer
- 2 Plug, M8x1, 3-pin

Type	L1	L2
VN-05	93.6	44.2
VN-07	107	60.5
VN-10		

Ordering data

with push-in connector and silencer

Nominal size [mm]	Switching function		High vacuum/Standard H		High suction rate/Standard L	
	Threshold value with fixed hysteresis	Threshold value with variable hysteresis	Part No.	Type	Part No.	Type
0.45	■	–	536 796	VN-05-H-T4-PQ2-VQ2-01-P	536 798	VN-05-L-T4-PQ2-VQ2-01-P
	–	■	536 797	VN-05-H-T4-PQ2-VQ2-02-P	536 799	VN-05-L-T4-PQ2-VQ2-02-P
0.7	■	–	536 800	VN-07-H-T4-PQ2-VQ2-01-P	536 802	VN-07-L-T4-PQ2-VQ2-01-P
	–	■	536 801	VN-07-H-T4-PQ2-VQ2-02-P	536 803	VN-07-L-T4-PQ2-VQ2-02-P
0.95	■	–	536 804	VN-10-H-T4-PQ2-VQ2-01-P	536 806	VN-10-L-T4-PQ2-VQ2-01-P
	–	■	536 805	VN-10-H-T4-PQ2-VQ2-02-P	536 807	VN-10-L-T4-PQ2-VQ2-02-P



- Simple, compact, robust design
- Quick and reliable setting down of parts via an ejector pulse from a pre-filled reservoir
- No wearing parts

Vacuum generators

Key features

FESTO

Product overview

Vacuum generator

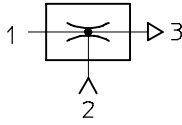

All Festo vacuum generators have a single-stage design and operate according to the venturi principle. The product families described below

have been designed for a wide range of applications. The different performance classes of the individual

product families make it possible to select vacuum generators tailored to suit specific requirements.

Standard and inline ejectors

VN-...

→ 6 / 1.1-9



- Nominal size
0.45 ... 3 mm
- Max. vacuum
93%
- Temperature range
0 ... +60 °C
- A range of extremely effective generators suitable for use directly in the workplace
- Available as straight or T-shaped housing
- Low space requirement
- Low-cost
- No wearing parts
- Extremely fast evacuation time
- Vacuum switch (optional)

VAD-.../VAK-...

→ 6 / 1.1-35



- Nominal size
0.5 ... 1.5 mm
- Max. vacuum
80%
- Temperature range
-20 ... +80 °C
- Range of vacuum generators with sturdy aluminium casing
- VAK-...: Built-in reservoir
- VAD-...: Connection for additional external reservoir
- Maintenance-free
- VAK-...: Reliable setting down of workpieces

Vacuum generators

Key features

FESTO

Compact ejectors

VADM-...VADMI-...

→ NO TAG



- Nominal size
0.45 ... 3 mm
- Max. vacuum
84%
- Temperature range
0 ... +60 °C
- Compact design
- Minimal installation work required
- Short response times
- Built-in solenoid valve (on/off)
- VADMI-...: Additional built-in solenoid valve for ejector pulse
- Filter with display
- Air-saving circuit (optional)
- Vacuum switch (optional)
- Reliable setting down of workpieces

VAD-M-.../VAD-M...-I-...

→ NO TAG

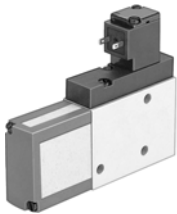

- Nominal size
0.7 ... 2 mm
- Max. vacuum
85%
- Temperature range
0 ... +40 °C
- Compact design
- Minimal installation work required
- Short response times
- Built-in solenoid valve (on/off)
- VAD-M-I-...: Additional built-in solenoid valve for ejector pulse
- Reliable setting down of workpieces

Vacuum generators VAD/VAK

Key features and type codes



At a glance

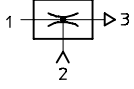

- Vacuum generation via ejector principle
- Mounting holes in metal housing
- Connecting thread for the suction cup

Compressed air flowing from 1 to 3 generates a vacuum at port 2 in accordance with the ejector principle.

The low noise levels which occur during exhaust can be further reduced with a silencer at port 3.

Workpieces can be picked up in any position. When the compressed air is turned off, the suction process ends and the vacuum dissipates.

During the suction process, the vacuum generator VAK fills a reservoir of approx. 32 cm³ with compressed

air, which creates an ejector pulse when the input pressure is switched off and reliably releases the workpiece from the suction cup.

Max. switching frequency approx. 10 Hz at 6 bar and with approx. 1 m suction line.

Vacuum generator VAD-... without ejector pulse

- Workpieces can be picked up in any position.
- Sturdy and resistant to environmental factors
- Easy to install
- No moving parts, maintenance-free
- Connecting threads and mounting holes available

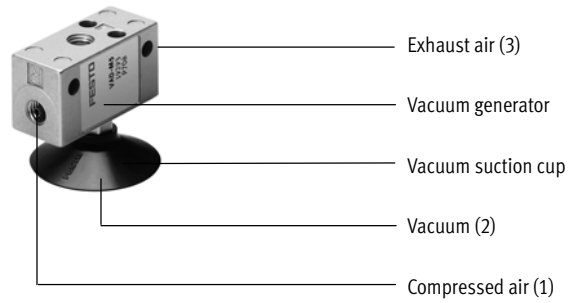

Vacuum generator VAK-... with ejector pulse

- Quick and reliable setting down of parts via an ejector pulse from a pre-filled reservoir
- Robust vacuum generator for a broad field of applications
- Optional silencer

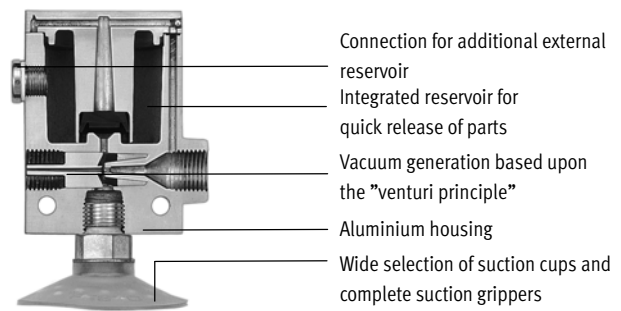
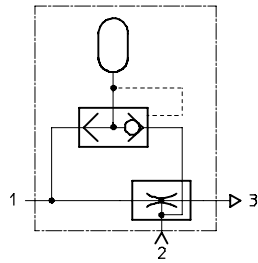

Type	
VAD	Vacuum generator
VAK	Vacuum generator

Connection sizes	
M5	Thread M5
1/8	Thread G1/8
1/4	Thread G1/4
3/8	Thread G3/8

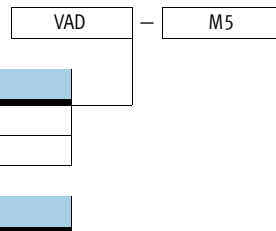

- Note
Possible combinations can be found in the ordering data.

Vacuum generators VAD/VAK

FESTO

Technical data

Function

VAD-...

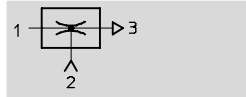

-  - Temperature range
-20 ... +80 °C

-  - Operating pressure
1.5 ... 10 bar

VAK-...

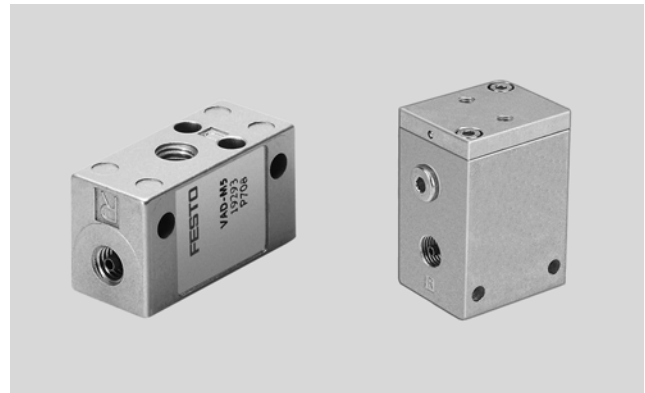
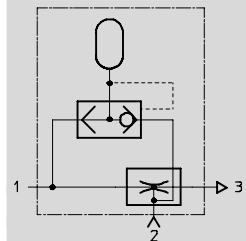

General technical data						
Type	VAD-...					VAK-...
Size	M5	G $\frac{1}{8}$	G $\frac{1}{4}$	G $\frac{3}{8}$	G $\frac{1}{4}$	
Design	Block-shaped					
Operating medium	Lubricated and unlubricated compressed air					
Mounting position	Any					
Ejector features	High vacuum					
Type of mounting	Via through-holes					
Pneumatic connection	M5	G $\frac{1}{8}$	G $\frac{1}{4}$	G $\frac{3}{8}$	G $\frac{1}{4}$	
Nominal size of laval nozzle [mm]	0.5	0.8	1.0	1.5	1.0	
Max. vacuum [%]	80					
Operating pressure [bar]	1.5 ... 10					

Ambient conditions		
Variant	VAD/VAK	
Ambient temperature [°C]	-20 ... +80	
Corrosion resistance CRC ¹⁾	2	
Note on material	Free of copper, PTFE and silicone	

- 1) Corrosion resistance class 2 according to Festo standard 940 070
Components requiring moderate corrosion resistance. Externally visible parts with primarily decorative surface requirements which are in direct contact with a surrounding industrial atmosphere or media such as cooling or lubricating agents.

Weights [g]						
Type	VAD-...					VAK-...
Size	M5	G $\frac{1}{8}$	G $\frac{1}{4}$	G $\frac{3}{8}$	G $\frac{1}{4}$	
VAD-.../VAK-...	14	40	90	155	265	

Vacuum generators VAD/VAK

Technical data

FESTO

Vacuum Δp as a function of operating pressure p

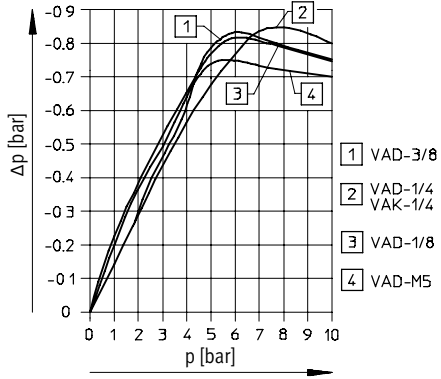

Suction capacity q_n as a function of vacuum p

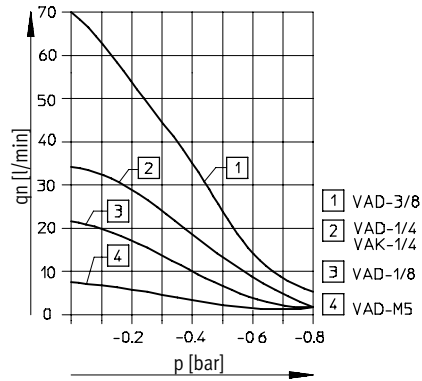

Suction capacity q_n as a function of operating pressure p

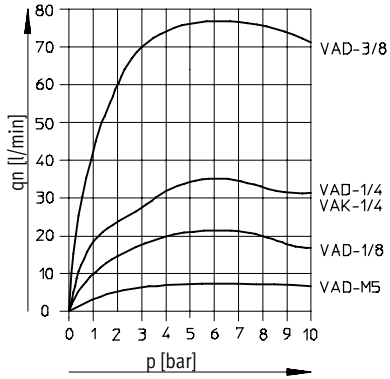

Air consumption q_n as a function of operating pressure p

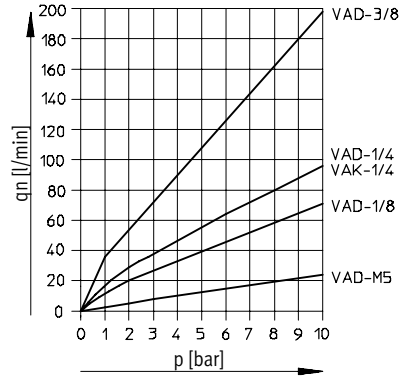

Noise level L_p as a function of operating pressure p

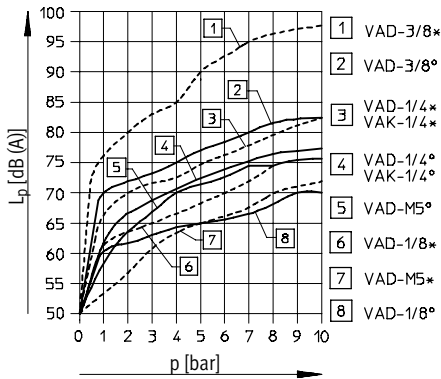

* = without silencer; ° = with silencer

Vacuum generators VAD/VAK

Technical data

FESTO

Dimensions

VAD-M5

VAD-1/8

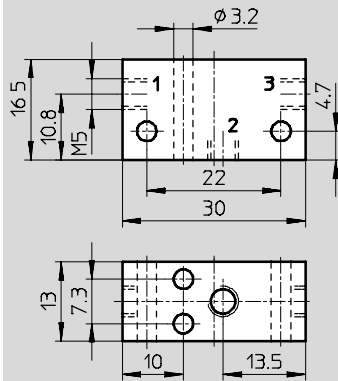

- 1 Compressed air connection
- 2 Vacuum port
- 3 Exhaust

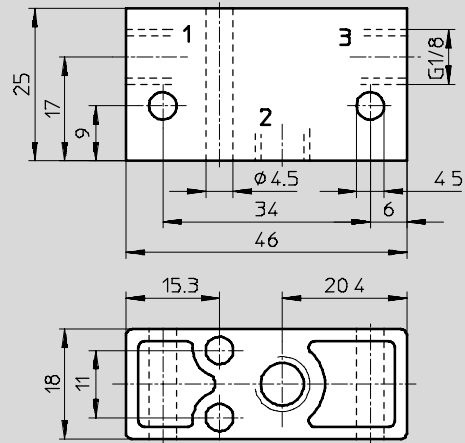

VAD-1/4

VAD-3/8

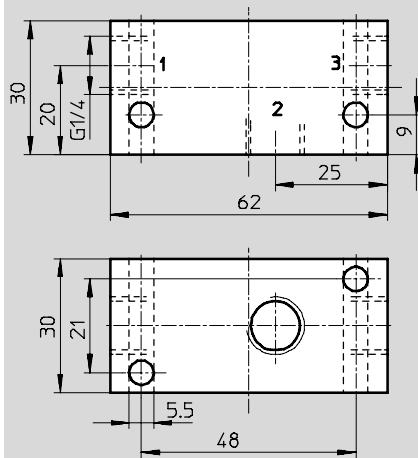

- 1 Compressed air connection
- 2 Vacuum port
- 3 Exhaust

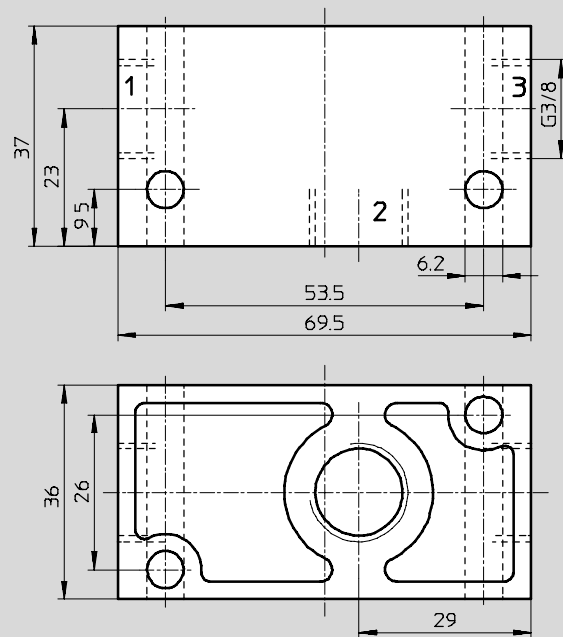

Vacuum generators
Pneumatic

1.1

Vacuum generators VAD/VAK

Technical data

FESTO

Vacuum generators
Pneumatic

1.1

Dimensions

VAK-1/4

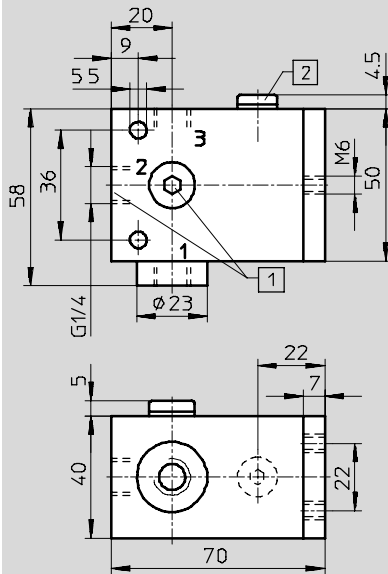

- 1 Alternative connection 2
- 2 Connection for additional reservoir

- 1 Compressed air connection
- 2 Vacuum port
- 3 Exhaust

Response time [s] as a function of vacuum [bar] at 6 bar operating pressure and 1 l volume

Type	Vacuum			
	0.2	0.4	0.6	0.8
VAD-M5				
Evacuation	1.3	3.53	8.18	26.6 ¹⁾
Air supply	2.8	3.8	4.65	5.45
VAD-1/8				
Evacuation	0.51	1.38	3.41	11.67
Air supply	0.89	1.3	1.64	1.98
VAD-1/4				
Evacuation	0.29	0.745	1.69	4.04 ¹⁾
Air supply	0.61	0.89	1.12	1.32
VAD-3/8				
Evacuation	0.142	0.35	0.817	2.72
Air supply	0.265	0.372	0.46	0.536 ¹⁾
VAK-1/4				
Evacuation	0.29	0.745	1.69	4.04 ¹⁾
Air supply	0.61	0.89	1.12	1.32

1) At 0.75 bar vacuum.

Ordering data

Pneumatic connection	Part No.	Type
Without ejector pulse		
M5	19 293	VAD-M5
G1/8	14 015	VAD-1/8
G1/4	9 394	VAD-1/4
G3/8	19 294	VAD-3/8
With ejector pulse		
G1/4	6 890	VAK-1/4