



- Electrically or pneumatically actuated valves
- Valves with internal or external pilot air
- Manifold mounting for 2 ... 10 valves or individual mounting

Solenoid/pneumatic valves, midi pneumatics



Features

FESTO

Directional control valves for standard applications
Midi Pneumatic

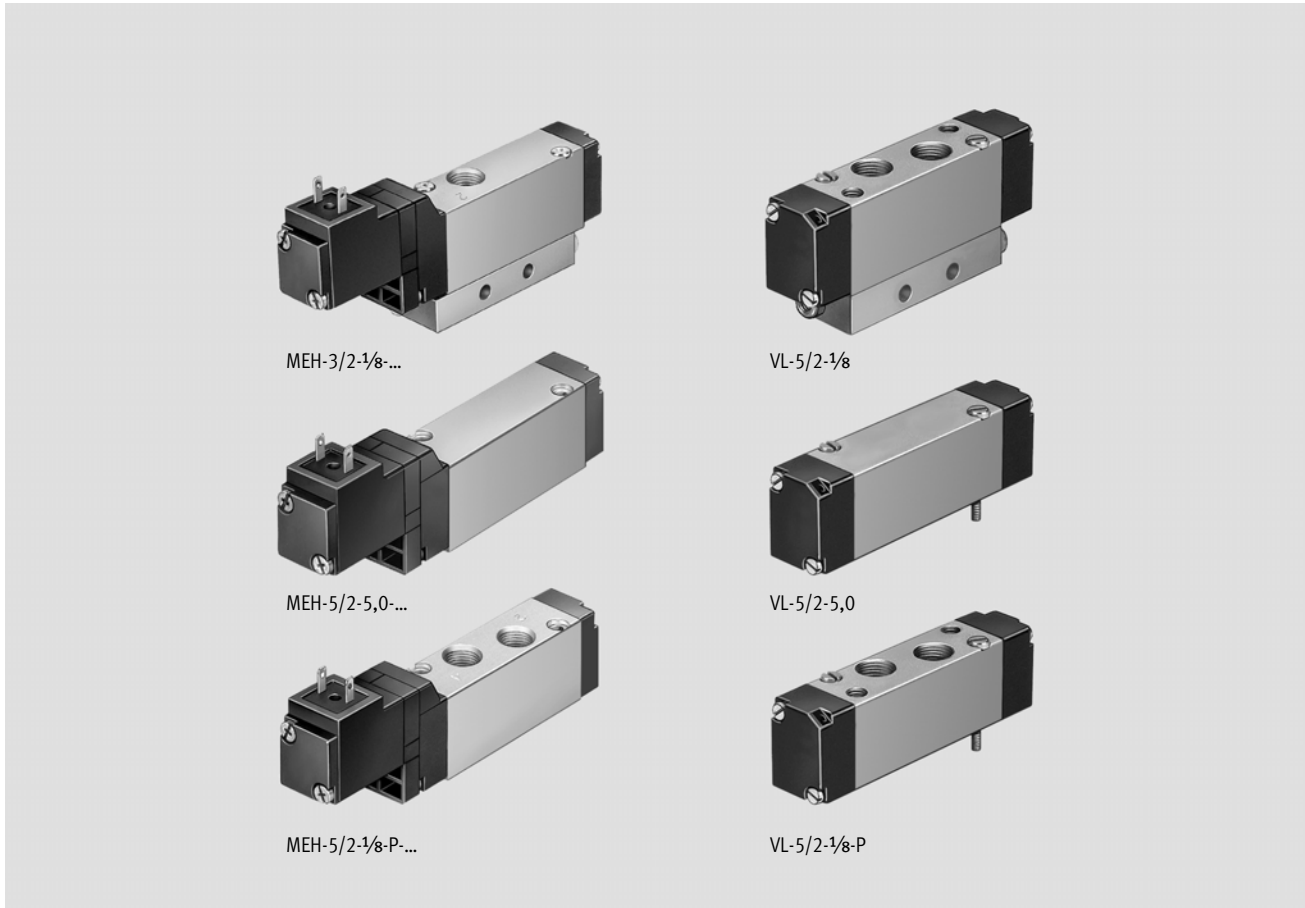
2.4



Parameter	Variants	Possible combinations	Mounting
<ul style="list-style-type: none"> -  - Flow rate 200 ... 700 l/min 	<ul style="list-style-type: none"> ■ Electrically and pneumatically actuated valves ■ 3/2, 5/2 and 5/3-way valves 	<ul style="list-style-type: none"> ■ Any number of valves can be added with series sub-bases ■ 2 ... 10 manifold mounted valves with blanking plates for spare positions ■ Prefabricated plug socket with cable, LED and protective circuit ■ Cable and solenoid coil for assembly by user ■ Manual override 	<ul style="list-style-type: none"> Semi in-line valves, threaded ■ Individual mounting Sub-base valves ■ Sub-base ■ Series sub-base Valves with in-line connection at top ■ PRS manifold
<ul style="list-style-type: none"> -  - Width 18 mm 	<ul style="list-style-type: none"> ■ Sub-base valves ■ Semi in-line valves 		
<ul style="list-style-type: none"> -  - Voltage 24 V DC 110 or 230 V AC 			

Solenoid/pneumatic valves, midi pneumatics

Features

Mounting options

Individual sub-base
Connection at side
AS-ME-1/8
AS-VL-1/8



Connection underneath
AU-ME-1/8



Manifold mounting
Series sub-base
AW-ME-1/8



AW-VL-1/8



Intermediate plate
ZP-ME-1/8



End plate kit
EP-ME-1/8



Blanking plate for spare positions
PRMEB-5



In-line manifold
PRS-ME-1/8

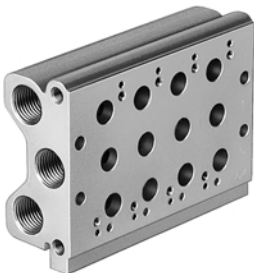

Blanking plate for spare positions
PRSB-ME-1/8

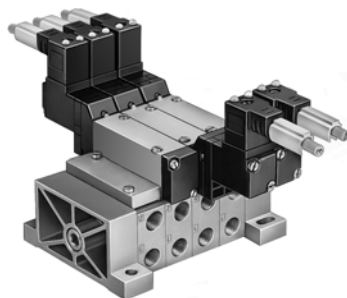

4. Solenoid valves MEH/MEBH, midi pneumatics

FESTO

Overview – Solenoid valves

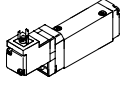
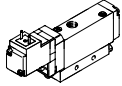
Function	Design	Type	Nominal flow rate [l/min]	Pneumatic connection	Operating voltage		Semi in-line valve	Sub-base valve
					[V DC]	[V AC]		
3/2-way valves		MEBH-3/2-...	700	5.0 mm	24	110, 230	-	■
			600	G1/8			■	-
		MOEBH-3/2-...	700	5.0 mm	24	110, 230	-	■
			600	G1/8			■	-
		MEH-3/2-...	700	5.0 mm	24	-	-	■
			600	G1/8			■	-
		MOEH-3/2-...	700	5.0 mm	24	-	-	■
			600	G1/8			■	-

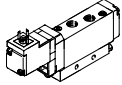
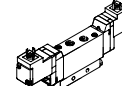
Function	Design	Type	Nominal flow rate [l/min]	Pneumatic connection	Operating voltage		Semi in-line valve	Sub-base valve	
					[V DC]	[V AC]			
5/2-way valves		MEBH-5/2-...	700	5.0 mm	24	110, 230	-	■	
			600	G1/8			■	-	
		MEH-5/2-...	700	5.0 mm	24	-	-	■	
			600	G1/8			■	-	
			JMEBH-5/2-...	700	5.0 mm	24	110, 230	-	■
				650	G1/8			■	-
	JMEH-5/2-...		700	5.0 mm	24	-	-	■	
			650	G1/8			■	-	

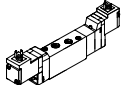
Function	Design	Type	Nominal flow rate [l/min]	Pneumatic connection	Operating voltage		Semi in-line valve	Sub-base valve
					[V DC]	[V AC]		
5/3-way valves		MEBH-5/3...	500	5.0 mm	24	110, 230	-	■
			600	G1/8			■	-
			400	5.0 mm			-	■
			300	G1/8			■	-
			400	5.0 mm			-	■
			200	G1/8			■	-
		MEH-5/3...	500	5.0 mm	24	-	-	■
			600	G1/8			■	-
			400	5.0 mm			-	■
			300	G1/8			■	-
			400	5.0 mm			-	■
			200	G1/8			■	-

5.Solenoid valves MEH/MEBH, midi pneumatics

Overview – Solenoid valves

Type	Pilot air supply		Type of reset		Normal position		→ Page
	internal	external	pneumatic spring	mechanical spring	closed	open	
Solenoid valve							
MEBH-3/2-...	■	-	-	■	■	-	2 / 2.4-9
MOEBH-3/2-...	■	-	-	■	-	■	
MEH-3/2-...	■	-	-	■	■	-	2 / 2.4-21
MOEH-3/2-...	■	-	-	■	-	■	



Type	Pilot air supply		Type of reset		Normal position		→ Page
	internal	external	pneumatic spring	mechanical spring	closed	open	
Solenoid valve							
MEBH-5/2-...	■	■	■	■	-	-	2 / 2.4-9
MEH-5/2-...	■	■	■	■	-	-	2 / 2.4-21
Double solenoid valve							
JMEBH-5/2-...	■	■	-	-	-	-	2 / 2.4-9
JMEH-5/2-...	■	■	-	-	-	-	2 / 2.4-21

Type	Pilot air supply		Type of reset		Normal position			→ Page
	internal	external	pneumatic spring	mechanical spring	closed	exhausted	pressurised	
Solenoid valve								
MEBH-5/3...	■	■	-	■	■	-	-	2 / 2.4-9
	■	■	-	■	-	■	-	
	■	■	-	■	-	-	■	
MEH-5/3...	■	■	-	■	■	-	-	2 / 2.4-21
	■	■	-	■	-	■	-	
	■	■	-	■	-	-	■	

6. Pneumatic valves VL/J, midi pneumatics

FESTO

Overview – Pneumatic valves

Function	Design	Type	Nominal flow rate [l/min]	Pneumatic connection	Semi in-line valve	Sub-base valve
5/2-way valves	Pneumatic valve					
		VL-5/2-...	700	5.0 mm	-	■
			600	G1/8	■	-
	Double pilot valve					
		J-5/2-...	700	5.0 mm	-	■
			650	G1/8	■	-

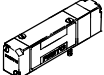
Function	Design	Type	Nominal flow rate [l/min]	Pneumatic connection	Semi in-line valve	Sub-base valve
5/3-way valves	Pneumatic valve					
		VL-5/3...	600	5.0 mm	-	■
			500	G1/8	■	-
			350	5.0 mm	-	■
			350	G1/8	■	-
			300	5.0 mm	-	■
300			G1/8	■	-	

7. Pneumatic valves VL/J, midi pneumatics

Overview – Pneumatic valves

Type	Pilot air supply		Type of reset		→ Page
	internal	external	pneumatic spring	mechanical spring	
Pneumatic valve					
VL-5/2-...	■	-	-	■	2 / 2.4-34
Double pilot valve					
J-5/2-...	■	-	-	-	2 / 2.4-34

Type	Pilot air supply		Normal position			→ Page
	internal	external	closed	exhausted	pressurised	
Pneumatic valve						
VL-5/3...	■	-	■	-	-	2 / 2.4-34
	■	-	-	■	-	
	■	-	-	-	■	

Solenoid valves MEH/MEBH, midi pneumatics

Type codes

MEBH – 5/2 – 1/8 – P – L – B – 110AC

Type	
MEBH	Single solenoid, with EB solenoid coil
MOEBH	Single solenoid, with EB solenoid coil, normally open
MEH	Single solenoid, with E solenoid coil
MOEH	Single solenoid, with E solenoid coil, normally open
JMEBH	Double solenoid, with EB solenoid coil
JMEH	Double solenoid, with E solenoid coil

Valve function	
3/2	3/2-way valve
5/2	5/2-way valve
5/3	5/3-way valve

Normal position	
G	Closed
E	Exhausted
B	Pressurised

Design, pneumatic connection/nominal size	
1/8	Semi in-line valve, thread G1/8
5.0	Sub-base valve, 5 mm

Mounting method	
P	On manifold PRS-ME

Type of reset	
	Mechanical spring
L	Pneumatic spring

Pilot air supply	
	Internal
S	External

Generation	
B	B series

Operating voltage	
	24 V DC
110AC	110 V AC
230AC	230 V AC

Solenoid valves MEBH, midi pneumatics

FESTO

Technical data

-  - Flow rate
200 ... 700 l/min

-  - Voltage
24 V DC
110/230 V AC

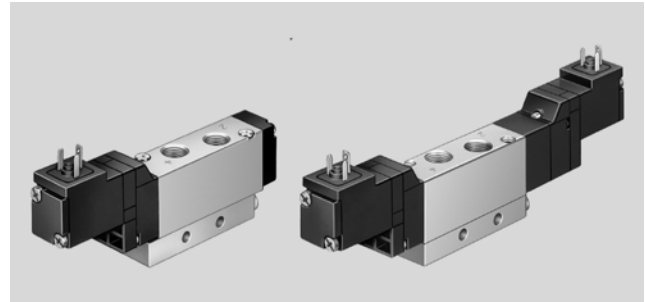

General technical data							
Type		MEBH-3/2-... MOEBH-3/2-...	MEBH-5/2-...	JMEBH-5/2-...	MEBH-5/3...		
Design		Piston spool					
Type of mounting	...-1/8	2 through-holes					
	...-5.0	On sub-base with two M3 screws					
	...-1/8-P	On manifold with two M3 screws					
Pneumatic connection	...-1/8	G1/8					
	...-5.0	Sub-base					
	...-1/8-P	G1/8					
Nominal size	[mm]	5					
Standard nominal flow rate 1 ↔ 2, 1 ↔ 4					G	E	B
	...-1/8	600/500	600	650	600	300	200
	...-5.0	700/600	700	700	500	400	400
	...-1/8-P	600/500	600	650	650	300	200
Materials		Housing: Aluminium Seals: Nitrile rubber					
Weight	[g]	...-1/8	105	105	142	153	
		...-5.0	105	105	146	150	
		...-1/8-P	105	105	142	153	

Operating and environmental conditions							
Type		MEBH-3/2-... MOEBH-3/2-...	MEBH-5/2-...	JMEBH-5/2-...	MEBH-5/3...		
Operating medium		Filtered compressed air, lubricated or unlubricated ¹⁾ Vacuum					
Operating pressure range	Internal pilot air supply	[bar]	2 ... 8	2.5 ... 8	1.5 ... 8	3 ... 8	
	External pilot air supply	[bar]	-	-0.9 ... +10			
Pilot pressure range		[bar]	-	2.5 ... 8	1.5 ... 8	3 ... 8	
Ambient temperature		[°C]	-5 ... +50				
Temperature of medium		[°C]	-5 ... +50				

1) Only oils of viscosity class 32 may be used for lubricated operation.

Solenoid valves MEBH, midi pneumatics

FESTO

Technical data

Valve response times [ms]							
Type	MEBH-3/2-... MOEBH-3/2-...		MEBH-5/2-...		JMEBH-5/2-...	MEBH-5/3...	
Type of reset	mechanical	pneumatic	mechanical	pneumatic	–	mechanical	pneumatic
On	10	–	10	15	–	12	–
Off	28	–	28	18	–	25	–
Changeover	–	–	–	–	10	–	–

Electrical data			
EB solenoid coil			
Electrical connection		Plug, square design to EN 175 301-803, type C	
Operating voltage	D.C. voltage	[V DC]	24
	AC voltage	[V AC]	110/230 (50 ... 60 Hz)
Coil characteristics	D.C. voltage	[W]	2.5
	AC voltage	[VA]	2.4
Protection class to EN 60 529		IP65 (in combination with plug socket)	

Solenoid valves MEBH, midi pneumatics

Technical data – 3/2-way valves

Dimensions

Download CAD data → www.festo.com/en/engineering

Semi in-line valve with thread G1/8

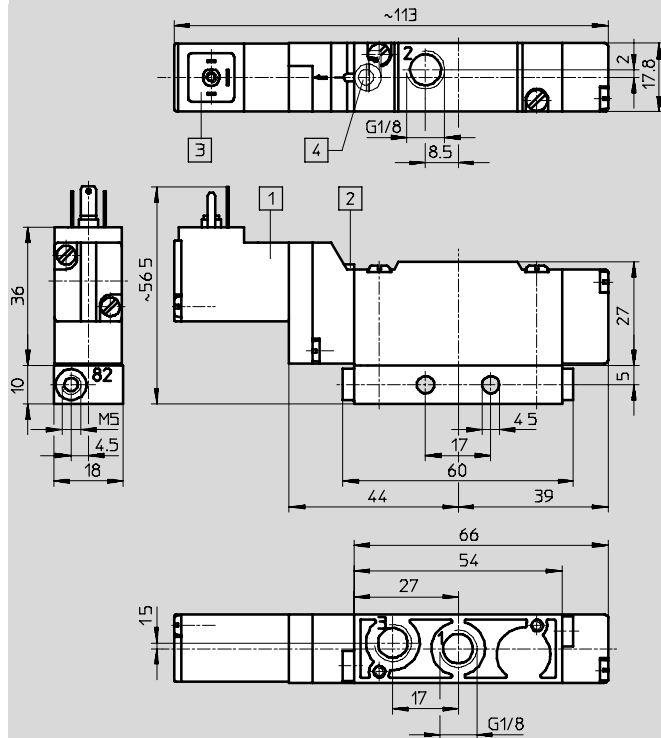

- 1 Solenoid coil can be rotated 180°¹⁾
 - 2 Manual override
 - 3 Suitable for plug sockets to EN 175 301-803, form C: MSSD-EB or KMEB-...
 - 4 Manual override tool (accessory) AHB-ME-1/8
- 1) The seal must not be turned!

Semi in-line valve for manifold PRS-ME

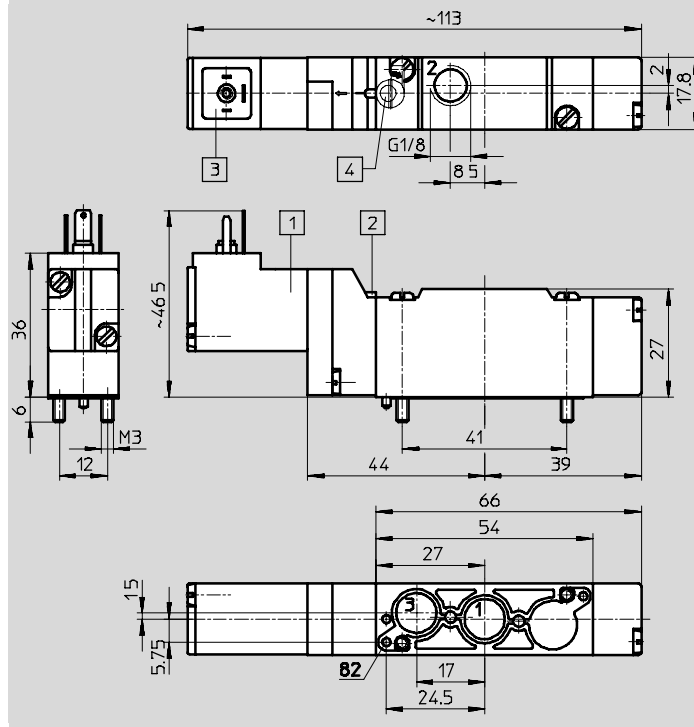

- 1 Solenoid coil can be rotated 180°¹⁾
 - 2 Manual override
 - 3 Suitable for plug sockets to EN 175 301-803, form C: MSSD-EB or KMEB-...
 - 4 Manual override tool (accessory) AHB-ME-1/8
- 1) The seal must not be turned!

Solenoid valves MEBH, midi pneumatics

Technical data – 3/2-way valves

FESTO

Directional control valves for standard applications
Midi Pneumatic

2.4

Dimensions

Download CAD data → www.festo.com/en/engineering

Sub-base valve

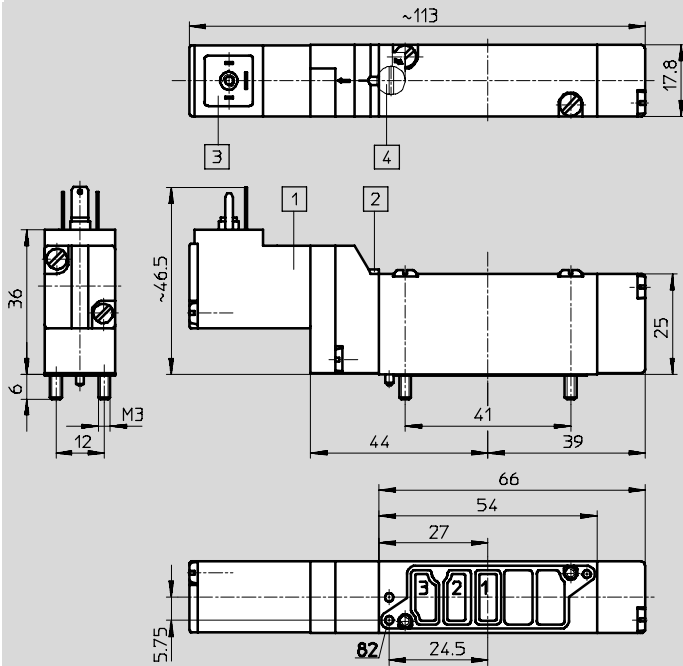

- 1 Solenoid coil can be rotated 180°¹⁾
 - 2 Manual override
 - 3 Suitable for plug sockets to EN 175 301-803, form C: MSSD-EB or KMEB-...
 - 4 Manual override tool (accessory) AHB-ME-1/8
- 1) The seal must not be turned!

Ordering data

Circuit symbol	Description	Voltage	Part No.	Type
Normally closed				
	Semi in-line valve with thread G1/8	24 V DC	172 998	MEBH-3/2-1/8-B
		110 V AC	173 042	MEBH-3/2-1/8-B-110AC
		230 V AC	173 084	MEBH-3/2-1/8-B-230AC
	Semi in-line valve for manifold PRS-ME	24 V DC	173 000	MEBH-3/2-1/8-P-B
		110 V AC	173 056	MEBH-3/2-1/8-P-B-110AC
		230 V AC	173 098	MEBH-3/2-1/8-P-B-230AC
	Sub-base valve	24 V DC	172 999	MEBH-3/2-5,0-B
		110 V AC	173 070	MEBH-3/2-5,0-B-110AC
		230 V AC	173 112	MEBH-3/2-5,0-B-230AC
Normally open				
	Semi in-line valve with thread G1/8	24 V DC	173 001	MOEBH-3/2-1/8-B
		110 V AC	173 053	MOEBH-3/2-1/8-B-110AC
		230 V AC	173 095	MOEBH-3/2-1/8-B-230AC
	Semi in-line valve for manifold PRS-ME	24 V DC	173 003	MOEBH-3/2-1/8-P-B
		110 V AC	173 067	MOEBH-3/2-1/8-P-B-110AC
		230 V AC	173 109	MOEBH-3/2-1/8-P-B-230AC
	Sub-base valve	24 V DC	173 002	MOEBH-3/2-5,0-B
		110 V AC	173 081	MOEBH-3/2-5,0-B-110AC
		230 V AC	173 123	MOEBH-3/2-5,0-B-230AC

Solenoid valves MEBH, midi pneumatics

Technical data – 5/2-way valves

FESTO

Dimensions

Download CAD data → www.festo.com/en/engineering

Semi in-line valve with thread G1/8

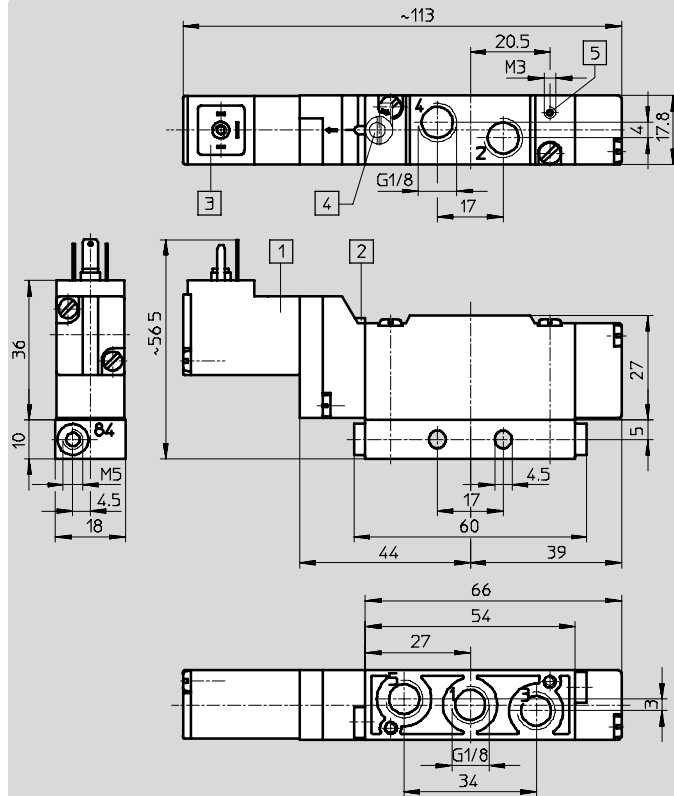

- 1 Solenoid coil can be rotated 180°¹⁾
- 2 Manual override
- 3 Suitable for plug sockets to EN 175 301-803, form C: MSSD-EB or KMEB-...
- 4 Manual override tool (accessory) AHB-ME-1/8
- 5 Port for external pilot air on S types

1) The seal must not be turned!

Semi in-line valve for manifold PRS-ME

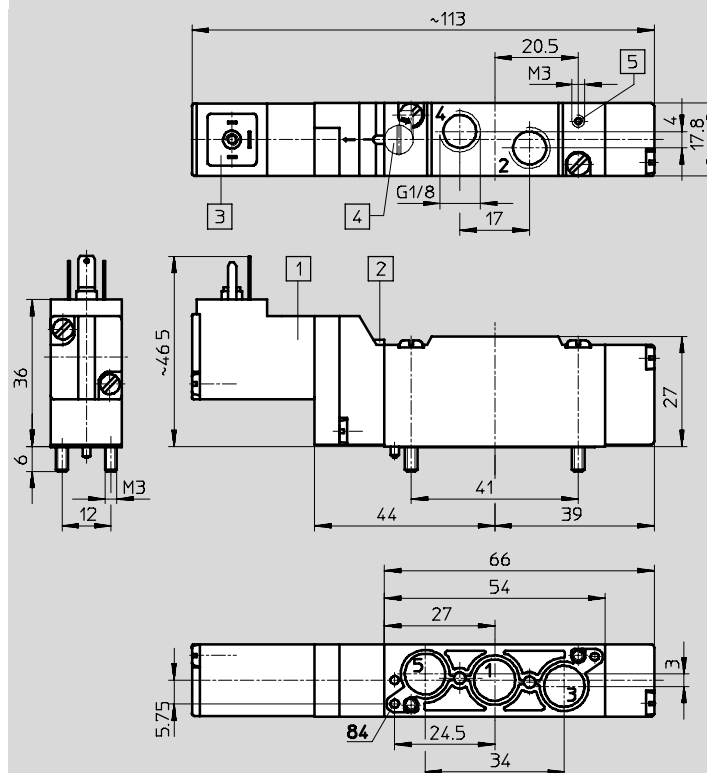

- 1 Solenoid coil can be rotated 180°¹⁾
- 2 Manual override
- 3 Suitable for plug sockets to EN 175 301-803, form C: MSSD-EB or KMEB-...
- 4 Manual override tool (accessory) AHB-ME-1/8
- 5 Port for external pilot air on S types

1) The seal must not be turned!

Directional control valves for standard applications
Midi Pneumatic

2.4

Solenoid valves MEBH, midi pneumatics

Technical data – 5/2-way valves

FESTO

Dimensions

Download CAD data → www.festo.com/en/engineering

Sub-base valve

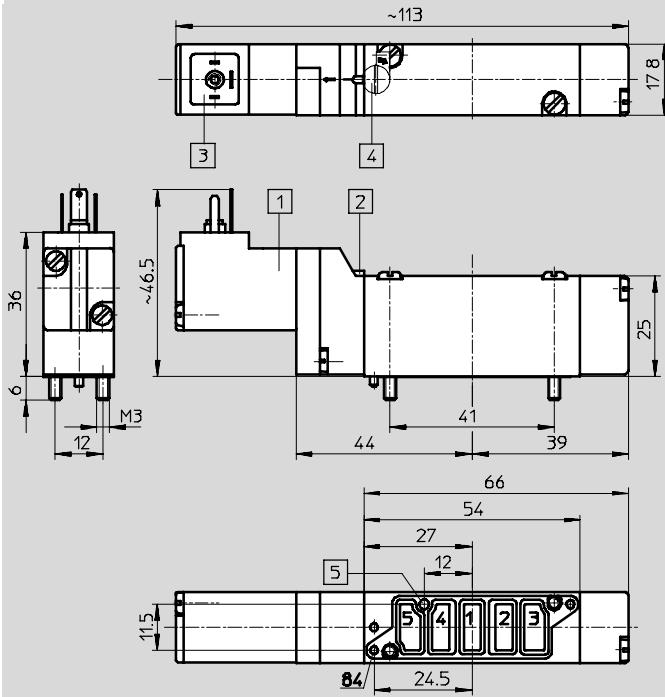

- 1 Solenoid coil can be rotated 180°¹⁾
 - 2 Manual override
 - 3 Suitable for plug sockets to EN 175 301-803, form C: MSSD-EB or KMEB-...
 - 4 Manual override tool (accessory) AHB-ME-1/8
 - 5 Port for external pilot air on S types
- 1) The seal must not be turned!

Directional control valves for standard applications
Midi Pneumatic

2.4

Solenoid valves MEBH, midi pneumatics

Technical data – 5/2-way valves

Ordering data				
Circuit symbol	Description	Voltage	Part No.	Type
Mechanical spring return, internal pilot air supply				
	Semi in-line valve with thread G $\frac{1}{8}$	24 V DC	173 004	MEBH-5/2- $\frac{1}{8}$ -B
		110 V AC	173 043	MEBH-5/2- $\frac{1}{8}$ -B-110AC
		230 V AC	173 085	MEBH-5/2- $\frac{1}{8}$ -B-230AC
	Semi in-line valve for manifold PRS-ME	24 V DC	173 006	MEBH-5/2- $\frac{1}{8}$ -P-B
		110 V AC	173 057	MEBH-5/2- $\frac{1}{8}$ -P-B-110AC
		230 V AC	173 099	MEBH-5/2- $\frac{1}{8}$ -P-B-230AC
	Sub-base valve	24 V DC	173 005	MEBH-5/2-5,0-B
		110 V AC	173 071	MEBH-5/2-5,0-B-110AC
		230 V AC	173 113	MEBH-5/2-5,0-B-230AC
Mechanical spring return, external pilot air supply				
	Semi in-line valve with thread G $\frac{1}{8}$	24 V DC	173 007	MEBH-5/2- $\frac{1}{8}$ -S-B
		110 V AC	173 046	MEBH-5/2- $\frac{1}{8}$ -S-B-110AC
		230 V AC	173 088	MEBH-5/2- $\frac{1}{8}$ -S-B-230AC
	Semi in-line valve for manifold PRS-ME	24 V DC	173 009	MEBH-5/2- $\frac{1}{8}$ -P-S-B
		110 V AC	173 060	MEBH-5/2- $\frac{1}{8}$ -P-S-B-110AC
		230 V AC	173 102	MEBH-5/2- $\frac{1}{8}$ -P-S-B-230AC
	Sub-base valve	24 V DC	173 008	MEBH-5/2-5,0-S-B
		110 V AC	173 074	MEBH-5/2-5,0-S-B-110AC
		230 V AC	173 116	MEBH-5/2-5,0-S-B-230AC
Pneumatic spring return, internal pilot air supply				
	Semi in-line valve with thread G $\frac{1}{8}$	24 V DC	173 010	MEBH-5/2- $\frac{1}{8}$ -L-B
		110 V AC	173 044	MEBH-5/2- $\frac{1}{8}$ -L-B-110AC
		230 V AC	173 086	MEBH-5/2- $\frac{1}{8}$ -L-B-230AC
	Semi in-line valve for manifold PRS-ME	24 V DC	173 012	MEBH-5/2- $\frac{1}{8}$ -P-L-B
		110 V AC	173 058	MEBH-5/2- $\frac{1}{8}$ -P-L-B-110AC
		230 V AC	173 100	MEBH-5/2- $\frac{1}{8}$ -P-L-B-230AC
	Sub-base valve	24 V DC	173 011	MEBH-5/2-5,0-L-B
		110 V AC	173 072	MEBH-5/2-5,0-L-B-110AC
		230 V AC	173 114	MEBH-5/2-5,0-L-B-230AC
Pneumatic spring return, external pilot air supply				
	Semi in-line valve with thread G $\frac{1}{8}$	24 V DC	173 013	MEBH-5/2- $\frac{1}{8}$ -L-S-B
		110 V AC	173 045	MEBH-5/2- $\frac{1}{8}$ -L-S-B-110AC
		230 V AC	173 087	MEBH-5/2- $\frac{1}{8}$ -L-S-B-230AC
	Semi in-line valve for manifold PRS-ME	24 V DC	173 015	MEBH-5/2- $\frac{1}{8}$ -P-L-S-B
		110 V AC	173 059	MEBH-5/2- $\frac{1}{8}$ -P-L-S-B-110AC
		230 V AC	173 101	MEBH-5/2- $\frac{1}{8}$ -P-L-S-B-230AC
	Sub-base valve	24 V DC	173 014	MEBH-5/2-5,0-L-S-B
		110 V AC	173 073	MEBH-5/2-5,0-L-S-B-110AC
		230 V AC	173 115	MEBH-5/2-5,0-L-S-B-230AC

Solenoid valves MEBH, midi pneumatics

Technical data – 5/2-way valves, double solenoid

FESTO

Directional control valves for standard applications
Midi Pneumatic

2.4

Dimensions

Download CAD data → www.festo.com/en/engineering

Semi in-line valve with thread G1/8

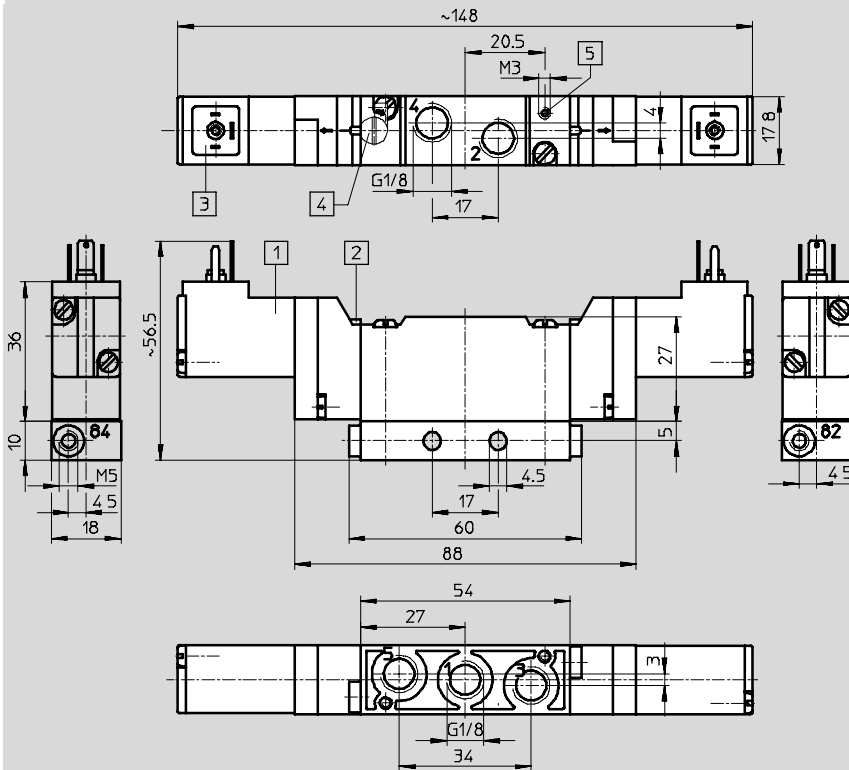

- 1) Solenoid coil can be rotated 180°¹⁾
- 2) Manual override
- 3) Suitable for plug sockets to EN 175 301-803, form C: MSSD-EB or KMEB-...
- 4) Manual override tool (accessory) AHB-ME-1/8
- 5) Port for external pilot air on S types

1) The seal must not be turned!

Semi in-line valve for manifold PRS-ME

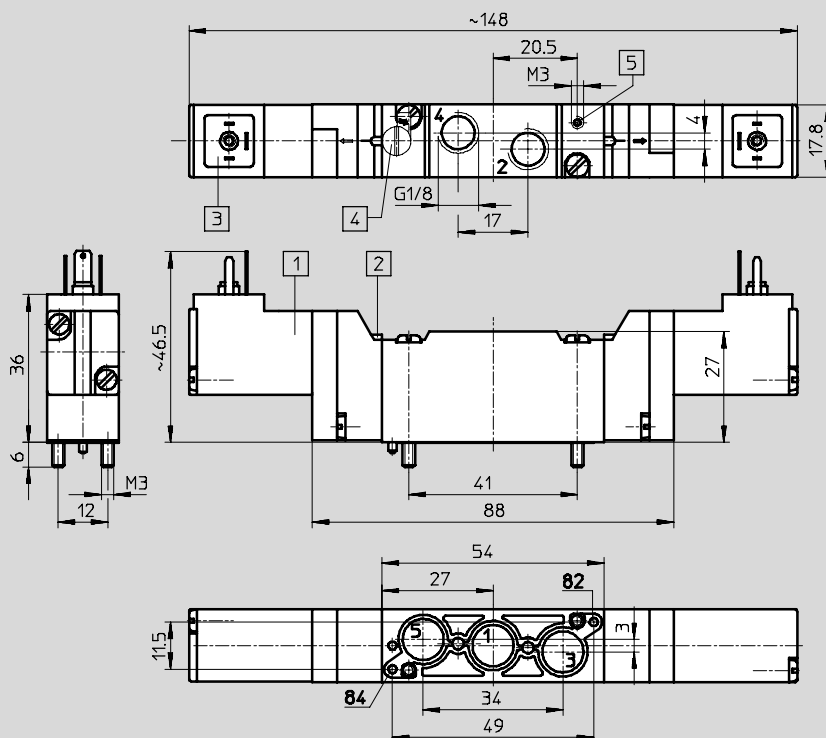

- 1) Solenoid coil can be rotated 180°¹⁾
- 2) Manual override
- 3) Suitable for plug sockets to EN 175 301-803, form C: MSSD-EB or KMEB-...
- 4) Manual override tool (accessory) AHB-ME-1/8
- 5) Port for external pilot air on S types

1) The seal must not be turned!

Solenoid valves MEBH, midi pneumatics

Technical data – 5/2-way valves, double solenoid



Dimensions

Download CAD data → www.festo.com/en/engineering

Sub-base valve

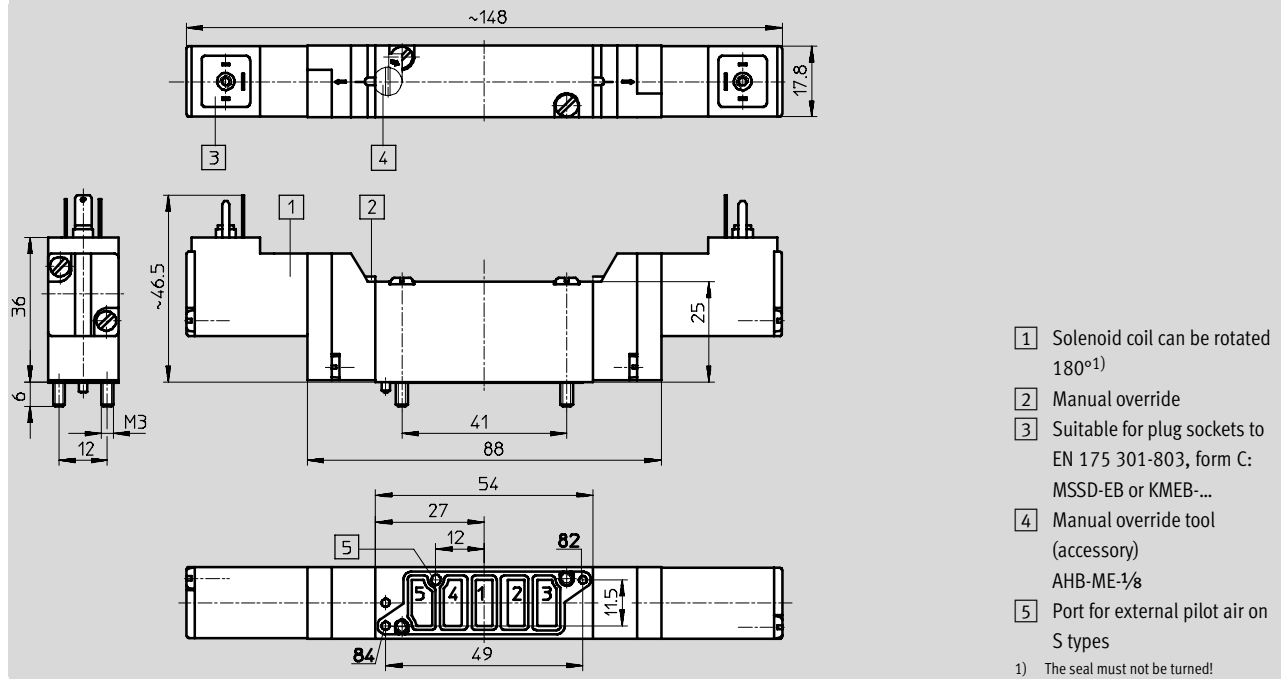

Ordering data

Circuit symbol	Description	Voltage	Part No.	Type
Internal pilot air supply				
	Semi in-line valve with thread G1/8	24 V DC	173 034	JMEBH-5/2-1/8-B
		110 V AC	173 040	JMEBH-5/2-1/8-B-110AC
		230 V AC	173 082	JMEBH-5/2-1/8-B-230AC
	Semi in-line valve for manifold PRS-ME	24 V DC	173 036	JMEBH-5/2-1/8-P-B
		110 V AC	173 054	JMEBH-5/2-1/8-P-B-110AC
		230 V AC	173 096	JMEBH-5/2-1/8-P-B-230AC
	Sub-base valve	24 V DC	173 035	JMEBH-5/2-5,0-B
		110 V AC	173 068	JMEBH-5/2-5,0-B-110AC
		230 V AC	173 110	JMEBH-5/2-5,0-B-230AC
External pilot air supply				
	Semi in-line valve with thread G1/8	24 V DC	173 037	JMEBH-5/2-1/8-S-B
		110 V AC	173 041	JMEBH-5/2-1/8-S-B-110AC
		230 V AC	173 083	JMEBH-5/2-1/8-S-B-230AC
	Semi in-line valve for manifold PRS-ME	24 V DC	173 039	JMEBH-5/2-1/8-P-S-B
		110 V AC	173 055	JMEBH-5/2-1/8-P-S-B-110AC
		230 V AC	173 097	JMEBH-5/2-1/8-P-S-B-230AC
	Sub-base valve	24 V DC	173 038	JMEBH-5/2-5,0-S-B
		110 V AC	173 069	JMEBH-5/2-5,0-S-B-110AC
		230 V AC	173 111	JMEBH-5/2-5,0-S-B-230AC

Solenoid valves MEBH, midi pneumatics

Technical data – 5/3-way valves



Directional control valves for standard applications
Midi Pneumatic

Dimensions

Download CAD data → www.festo.com/en/engineering

Semi in-line valve with thread G1/8

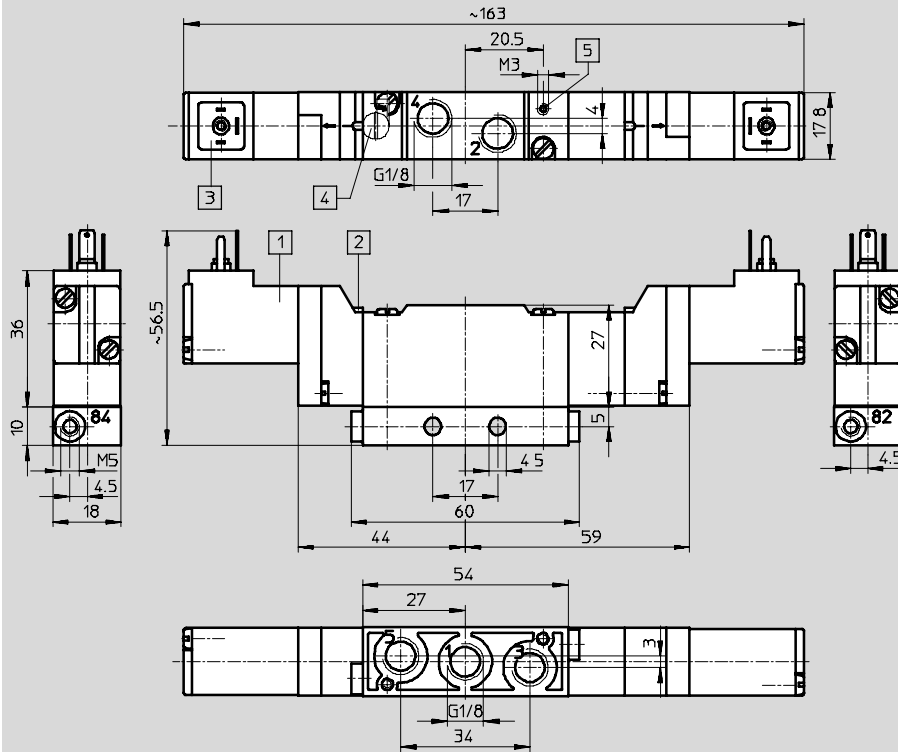

- 1 Solenoid coil can be rotated 180°¹⁾
 - 2 Manual override
 - 3 Suitable for plug sockets to EN 175 301-803, form C: MSSD-EB or KMEB-...
 - 4 Manual override tool (accessory) AHB-ME-1/8
 - 5 Port for external pilot air on S types
- 1) The seal must not be turned!

2.4

Semi in-line valve for manifold PRS-ME

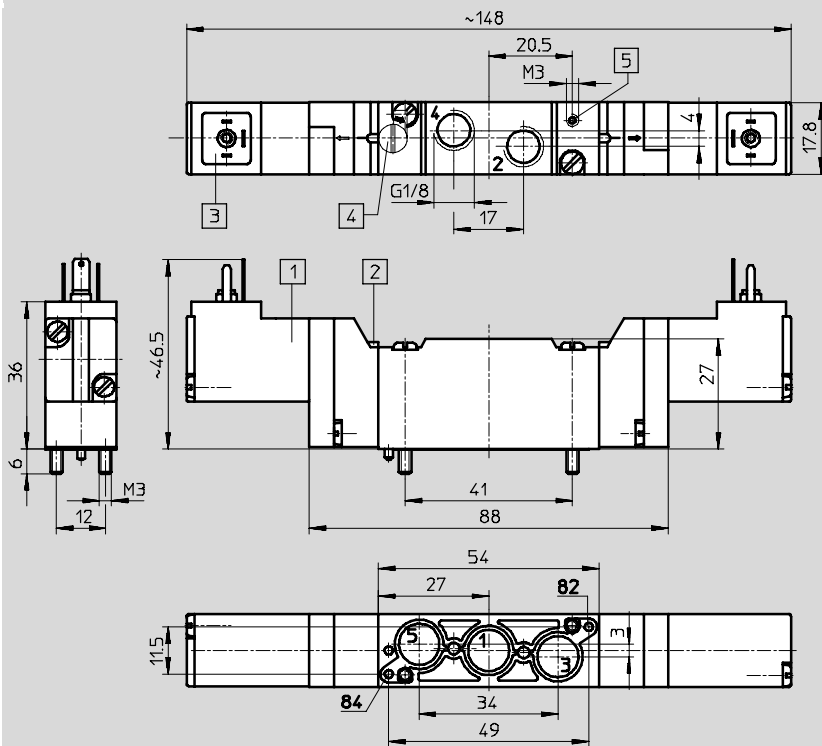

- 1 Solenoid coil can be rotated 180°¹⁾
 - 2 Manual override
 - 3 Suitable for plug sockets to EN 175 301-803, form C: MSSD-EB or KMEB-...
 - 4 Manual override tool (accessory) AHB-ME-1/8
 - 5 Port for external pilot air on S types
- 1) The seal must not be turned!

Solenoid valves MEBH, midi pneumatics

Technical data – 5/3-way valves

FESTO

Dimensions

Download CAD data → www.festo.com/en/engineering

Sub-base valve

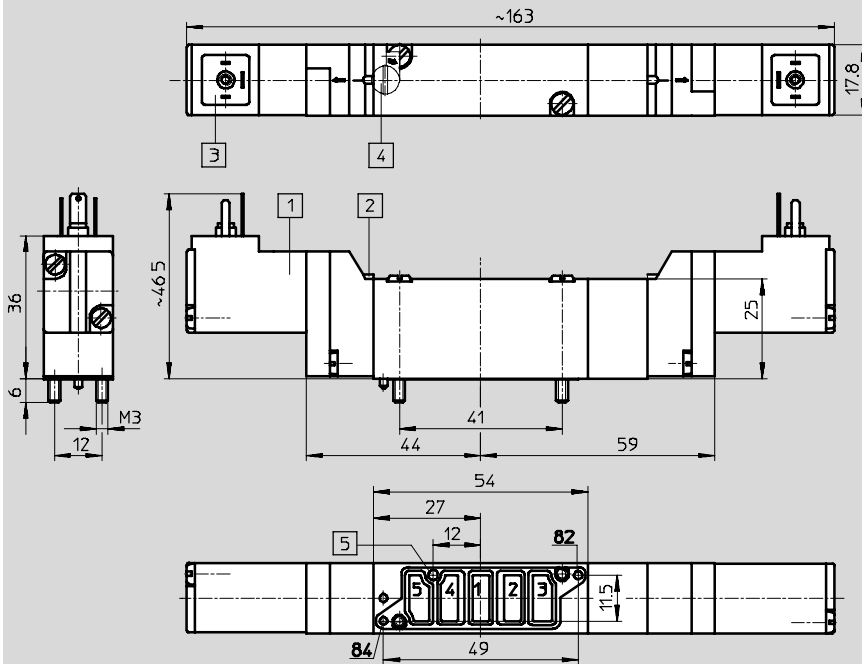

- 1 Solenoid coil can be rotated 180°¹⁾
 - 2 Manual override
 - 3 Suitable for plug sockets to EN 175 301-803, form C: MSSD-EB or KMEB-...
 - 4 Manual override tool (accessory) AHB-ME-1/8
 - 5 Port for external pilot air on S types
- 1) The seal must not be turned!

Ordering data

Circuit symbol	Description	Voltage	Part No.	Type
Normally closed, internal pilot air supply				
	Semi in-line valve with thread G1/8	24 V DC	173 016	MEBH-5/3G-1/8-B
		110 V AC	173 051	MEBH-5/3G-1/8-B-110AC
		230 V AC	173 093	MEBH-5/3G-1/8-B-230AC
	Semi in-line valve for manifold PRS-ME	24 V DC	173 018	MEBH-5/3G-1/8-P-B
		110 V AC	173 065	MEBH-5/3G-1/8-P-B-110AC
		230 V AC	173 107	MEBH-5/3G-1/8-P-B-230AC
	Sub-base valve	24 V DC	173 017	MEBH-5/3G-5,0-B
		110 V AC	173 079	MEBH-5/3G-5,0-B-110AC
		230 V AC	173 121	MEBH-5/3G-5,0-B-230AC
Normally closed, external pilot air supply				
	Semi in-line valve with thread G1/8	24 V DC	173 019	MEBH-5/3G-1/8-S-B
		110 V AC	173 052	MEBH-5/3G-1/8-S-B-110AC
		230 V AC	173 094	MEBH-5/3G-1/8-S-B-230AC
	Semi in-line valve for manifold PRS-ME	24 V DC	173 021	MEBH-5/3G-1/8-P-S-B
		110 V AC	173 066	MEBH-5/3G-1/8-P-S-B-110AC
		230 V AC	173 108	MEBH-5/3G-1/8-P-S-B-230AC
	Sub-base valve	24 V DC	173 020	MEBH-5/3G-5,0-S-B
		110 V AC	173 080	MEBH-5/3G-5,0-S-B-110AC
		230 V AC	173 122	MEBH-5/3G-5,0-S-B-230AC

Directional control valves for standard applications
Midi Pneumatic

2.4

Solenoid valves MEBH, midi pneumatics

FESTO

Technical data – 5/3-way valves

Directional control valves for standard applications
Midi Pneumatic

2.4

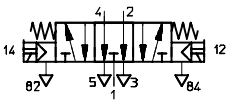
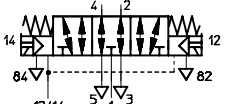
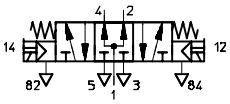
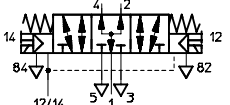
Ordering data				
Circuit symbol	Description	Voltage	Part No.	Type
Normally exhausted, internal pilot air supply				
	Semi in-line valve with thread G $\frac{1}{8}$	24 V DC	173 022	MEBH-5/3E- $\frac{1}{8}$ -B
		110 V AC	173 049	MEBH-5/3E- $\frac{1}{8}$ -B-110AC
		230 V AC	173 091	MEBH-5/3E- $\frac{1}{8}$ -B-230AC
	Semi in-line valve for manifold PRS-ME	24 V DC	173 024	MEBH-5/3E- $\frac{1}{8}$ -P-B
		110 V AC	173 063	MEBH-5/3E- $\frac{1}{8}$ -P-B-110AC
		230 V AC	173 105	MEBH-5/3E- $\frac{1}{8}$ -P-B-230AC
	Sub-base valve	24 V DC	173 023	MEBH-5/3E-5,0-B
		110 V AC	173 077	MEBH-5/3E-5,0-B-110AC
		230 V AC	173 119	MEBH-5/3E-5,0-B-230AC
Normally exhausted, external pilot air supply				
	Semi in-line valve with thread G $\frac{1}{8}$	24 V DC	173 025	MEBH-5/3E- $\frac{1}{8}$ -S-B
		110 V AC	173 050	MEBH-5/3E- $\frac{1}{8}$ -S-B-110AC
		230 V AC	173 092	MEBH-5/3E- $\frac{1}{8}$ -S-B-230AC
	Semi in-line valve for manifold PRS-ME	24 V DC	173 027	MEBH-5/3E- $\frac{1}{8}$ -P-S-B
		110 V AC	173 064	MEBH-5/3E- $\frac{1}{8}$ -P-S-B-110AC
		230 V AC	173 106	MEBH-5/3E- $\frac{1}{8}$ -P-S-B-230AC
	Sub-base valve	24 V DC	173 026	MEBH-5/3E-5,0-S-B
		110 V AC	173 078	MEBH-5/3E-5,0-S-B-110AC
		230 V AC	173 120	MEBH-5/3E-5,0-S-B-230AC
Normally pressurised, internal pilot air supply				
	Semi in-line valve with thread G $\frac{1}{8}$	24 V DC	173 028	MEBH-5/3B- $\frac{1}{8}$ -B
		110 V AC	173 047	MEBH-5/3B- $\frac{1}{8}$ -B-110AC
		230 V AC	173 089	MEBH-5/3B- $\frac{1}{8}$ -B-230AC
	Semi in-line valve for manifold PRS-ME	24 V DC	173 030	MEBH-5/3B- $\frac{1}{8}$ -P-B
		110 V AC	173 061	MEBH-5/3B- $\frac{1}{8}$ -P-B-110AC
		230 V AC	173 103	MEBH-5/3B- $\frac{1}{8}$ -P-B-230AC
	Sub-base valve	24 V DC	173 029	MEBH-5/3B-5,0-B
		110 V AC	173 075	MEBH-5/3B-5,0-B-110AC
		230 V AC	173 117	MEBH-5/3B-5,0-B-230AC
Normally pressurised, external pilot air supply				
	Semi in-line valve with thread G $\frac{1}{8}$	24 V DC	173 031	MEBH-5/3B- $\frac{1}{8}$ -S-B
		110 V AC	173 048	MEBH-5/3B- $\frac{1}{8}$ -S-B-110AC
		230 V AC	173 090	MEBH-5/3B- $\frac{1}{8}$ -S-B-230AC
	Semi in-line valve for manifold PRS-ME	24 V DC	173 033	MEBH-5/3B- $\frac{1}{8}$ -P-S-B
		110 V AC	173 062	MEBH-5/3B- $\frac{1}{8}$ -P-S-B-110AC
		230 V AC	173 104	MEBH-5/3B- $\frac{1}{8}$ -P-S-B-230AC
	Sub-base valve	24 V DC	173 032	MEBH-5/3B-5,0-S-B
		110 V AC	173 076	MEBH-5/3B-5,0-S-B-110AC
		230 V AC	173 118	MEBH-5/3B-5,0-S-B-230AC

Solenoid valves MEH, midi pneumatics

FESTO

Technical data

-  - Flow rate
200 ... 700 l/min

-  - Voltage
24 V DC

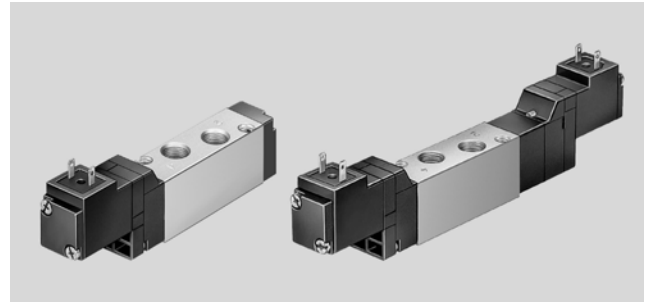

General technical data							
Type		MEH-3/2-... MOEH-3/2-...	MEH-5/2-...	JMEH-5/2-...	MEH-5/3...		
Design		Piston spool					
Type of mounting	...-1/8	2 through-holes					
	...-5.0	On sub-base with two M3 screws					
	...-1/8-P	On manifold with two M3 screws					
Pneumatic connection	...-1/8	G1/8					
	...-5.0	Sub-base					
	...-1/8-P	G1/8					
Nominal size	[mm]	5					
Standard nominal flow rate 1 → 2, 1 → 4					G	E	B
	...-1/8	600/500	600	650	600	300	200
	...-5.0	700/600	700	700	500	400	400
	...-1/8-P	600/500	600	650	650	300	200
Materials		Housing: Aluminium Seals: Nitrile rubber					
Weight	[g]						
	...-1/8	105	105	142	153		
	...-5.0	105	105	146	150		
...-1/8-P	105	105	142	153			

Operating and environmental conditions							
Type		MEH-3/2-... MOEH-3/2-...	MEH-5/2-...	JMEH-5/2-...	MEH-5/3...		
Operating medium		Filtered compressed air, lubricated or unlubricated ¹⁾ Vacuum					
Operating pressure range	Internal pilot air supply	[bar]	2 ... 8	2.5 ... 8	1.5 ... 8	3 ... 8	
	External pilot air supply	[bar]	-	-0.9 ... +10			
Pilot pressure range		[bar]	-	2.5 ... 8	1.5 ... 8	3 ... 8	
Ambient temperature		[°C]	-5 ... +50				
Temperature of medium		[°C]	-5 ... +50				

1) Only oils of viscosity class 32 may be used for lubricated operation.

Solenoid valves MEH, midi pneumatics



Technical data

Valve response times [ms]							
Type	MEH-3/2-... MOEH-3/2-...		MEH-5/2-...		JMEH-5/2-...	MEH-5/3...	
Type of reset	mechanical	pneumatic	mechanical	pneumatic	–	mechanical	pneumatic
On	10	–	10	15	–	12	–
Off	28	–	28	18	–	25	–
Changeover	–	–	–	–	10	–	–

Electrical data	
E solenoid coil	
Electrical connection	Plug, square
Operating voltage	[V DC] 24
Coil characteristics	[W] 1.5
Protection class to EN 60 529	IP65 (in combination with plug socket)

Directional control valves for standard applications
Midi Pneumatic

2.4

Solenoid valves MEH, midi pneumatics

Technical data – 3/2-way valves



Dimensions

Download CAD data → www.festo.com/en/engineering

Semi in-line valve with thread G1/8

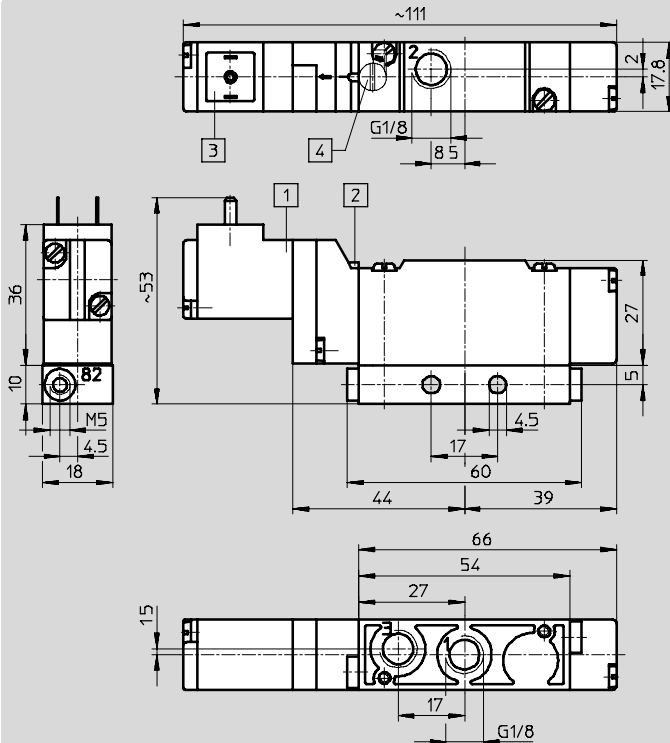

- 1) Solenoid coil can be rotated 180°¹⁾
 - 2) Manual override
 - 3) Suitable for terminal sockets to DIN 46 247 or plug sockets MSSD-E type KME type
 - 4) Manual override tool (accessory) AHB-ME-1/8
- 1) The seal must not be turned!

Semi in-line valve for manifold PRS-ME

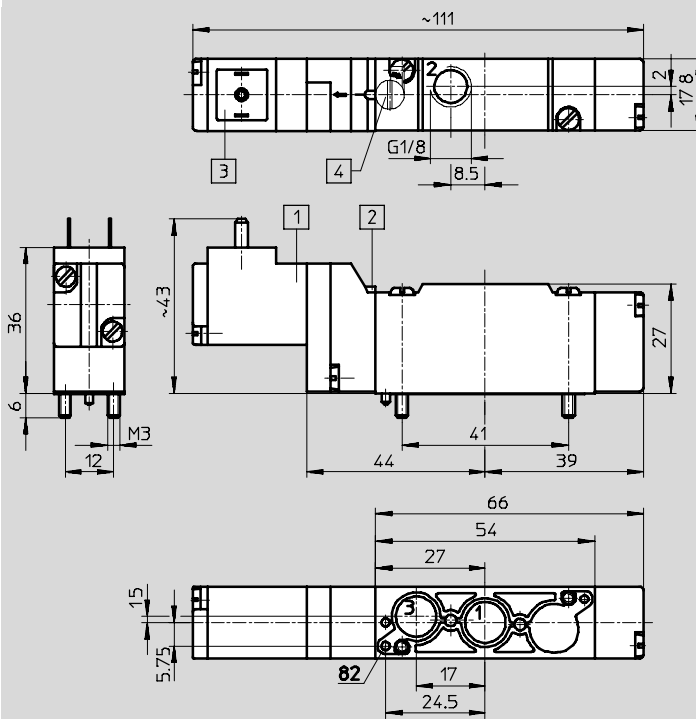

- 1) Solenoid coil can be rotated 180°¹⁾
 - 2) Manual override
 - 3) Suitable for terminal sockets to DIN 46 247 or plug sockets MSSD-E type KME type
 - 4) Manual override tool (accessory) AHB-ME-1/8
- 1) The seal must not be turned!

Directional control valves for standard applications
Midi Pneumatic

2.4

Solenoid valves MEH, midi pneumatics

Technical data – 3/2-way valves



Directional control valves for standard applications
Midi Pneumatic

2.4

Dimensions

Download CAD data → www.festo.com/en/engineering

Sub-base valve

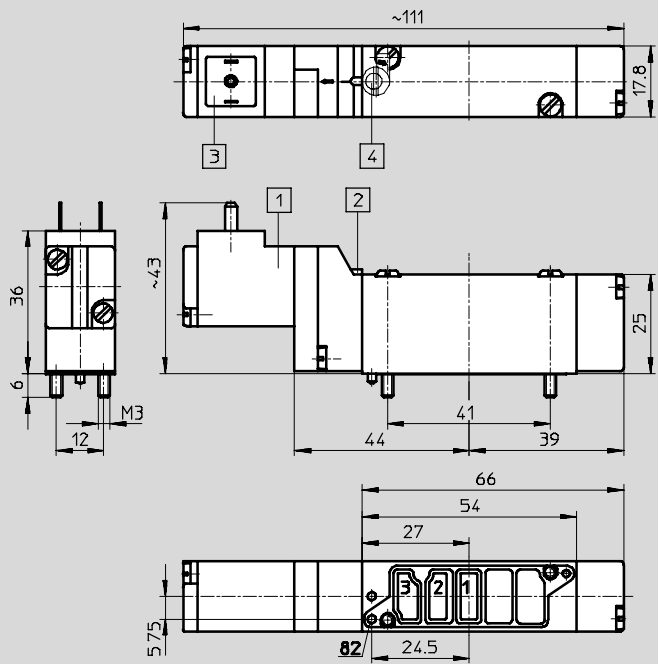

- 1 Solenoid coil can be rotated 180°¹⁾
 - 2 Manual override
 - 3 Suitable for terminal sockets to DIN 46 247 or plug sockets MSSD-E type KME type
 - 4 Manual override tool (accessory) AHB-ME-1/8
- 1) The seal must not be turned!

Ordering data

Circuit symbol	Description	Voltage	Part No.	Type
Normally closed				
	Semi in-line valve with thread G1/8	24 V DC	173 124	MEH-3/2-1/8-B
	Semi in-line valve for manifold PRS-ME		173 126	MEH-3/2-1/8-P-B
	Sub-base valve		173 125	MEH-3/2-5,0-B
Normally open				
	Semi in-line valve with thread G1/8	24 V DC	173 428	MOEH-3/2-1/8-B
	Semi in-line valve for manifold PRS-ME		173 430	MOEH-3/2-1/8-P-B
	Sub-base valve		173 429	MOEH-3/2-5,0-B

Solenoid valves MEH, midi pneumatics

Technical data – 5/2-way valves

FESTO

Dimensions

Download CAD data → www.festo.com/en/engineering

Semi in-line valve with thread G1/8

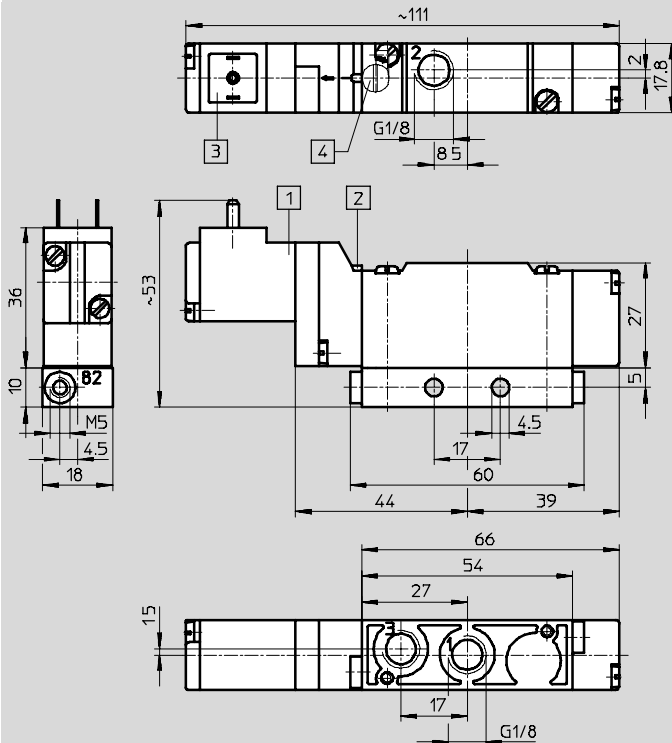

- 1 Solenoid coil can be rotated 180°¹⁾
 - 2 Manual override
 - 3 Suitable for terminal sockets to DIN 46 247 or plug sockets MSSD-E type KME type
 - 4 Manual override tool (accessory) AHB-ME-1/8
 - 5 Port for external pilot air on S types
- 1) The seal must not be turned!

Semi in-line valve for manifold PRS-ME

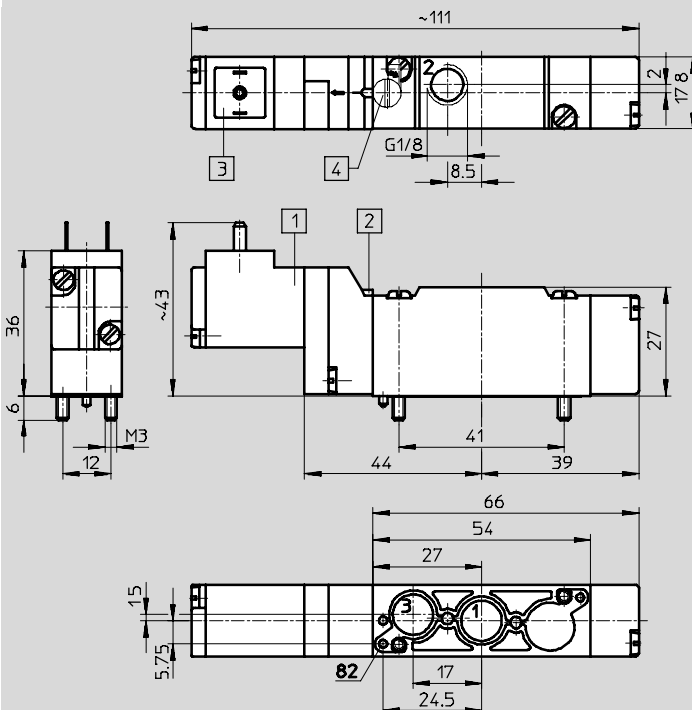

- 1 Solenoid coil can be rotated 180°¹⁾
 - 2 Manual override
 - 3 Suitable for terminal sockets to DIN 46 247 or plug sockets MSSD-E type KME type
 - 4 Manual override tool (accessory) AHB-ME-1/8
 - 5 Port for external pilot air on S types
- 1) The seal must not be turned!

Directional control valves for standard applications
Midi Pneumatic

2.4

Solenoid valves MEH, midi pneumatics

Technical data – 5/2-way valves

FESTO

Dimensions

Download CAD data → www.festo.com/en/engineering

Sub-base valve

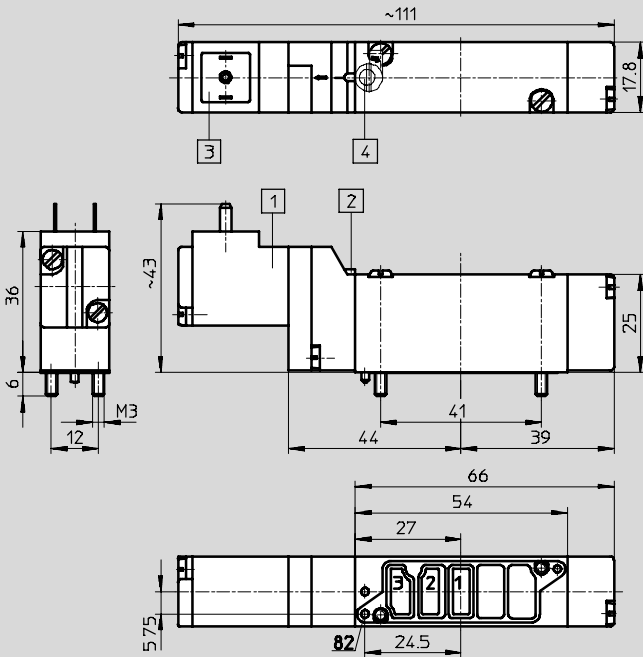

- 1 Solenoid coil can be rotated 180°¹⁾
 - 2 Manual override
 - 3 Suitable for terminal sockets to DIN 46 247 or plug sockets MSSD-E type KME type
 - 4 Manual override tool (accessory) AHB-ME-1/8
 - 5 Port for external pilot air on S types
- 1) The seal must not be turned!

Solenoid valves MEH, midi pneumatics



Technical data – 5/2-way valves

Ordering data				
Circuit symbol	Description	Voltage	Part No.	Type
Mechanical spring return, internal pilot air supply				
	Semi in-line valve with thread G $\frac{1}{8}$	24 V DC	173 127	MEH-5/2- $\frac{1}{8}$ -B
	Semi in-line valve for manifold PRS-ME		173 129	MEH-5/2- $\frac{1}{8}$ -P-B
	Sub-base valve		173 128	MEH-5/2-5,0-B
Mechanical spring return, external pilot air supply				
	Semi in-line valve with thread G $\frac{1}{8}$	24 V DC	173 130	MEH-5/2- $\frac{1}{8}$ -S-B
	Semi in-line valve for manifold PRS-ME		173 132	MEH-5/2- $\frac{1}{8}$ -P-S-B
	Sub-base valve		173 131	MEH-5/2-5,0-S-B
Pneumatic spring return, internal pilot air supply				
	Semi in-line valve with thread G $\frac{1}{8}$	24 V DC	173 133	MEH-5/2- $\frac{1}{8}$ -L-B
	Semi in-line valve for manifold PRS-ME		173 135	MEH-5/2- $\frac{1}{8}$ -P-L-B
	Sub-base valve		173 134	MEH-5/2-5,0-L-B
Pneumatic spring return, external pilot air supply				
	Semi in-line valve with thread G $\frac{1}{8}$	24 V DC	173 136	MEH-5/2- $\frac{1}{8}$ -L-S-B
	Semi in-line valve for manifold PRS-ME		173 138	MEH-5/2- $\frac{1}{8}$ -P-L-S-B
	Sub-base valve		173 137	MEH-5/2-5,0-L-S-B

Solenoid valves MEH, midi pneumatics

Technical data – 5/2-way valves, double solenoid

FESTO

Directional control valves for standard applications
Midi Pneumatic

2.4

Dimensions

Download CAD data → www.festo.com/en/engineering

Semi in-line valve with thread G1/8

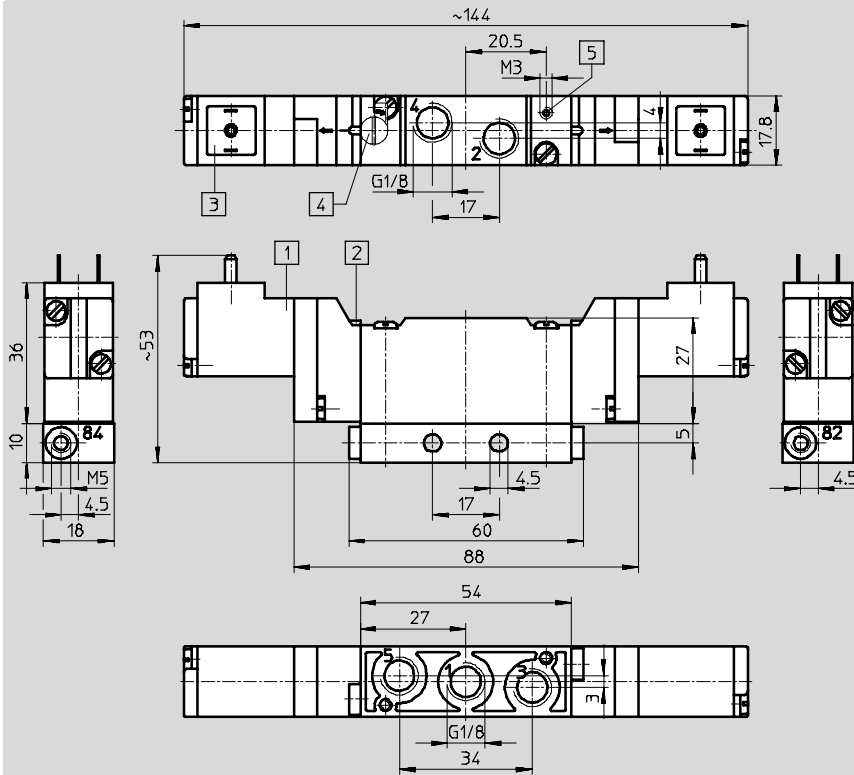

- 1) Solenoid coil can be rotated 180°¹⁾
 - 2) Manual override
 - 3) Suitable for terminal sockets to DIN 46 247 or plug sockets MSSD-E type KME type
 - 4) Manual override tool (accessory) AHB-ME-1/8
 - 5) Port for external pilot air on S types
- 1) The seal must not be turned!

Semi in-line valve for manifold PRS-ME

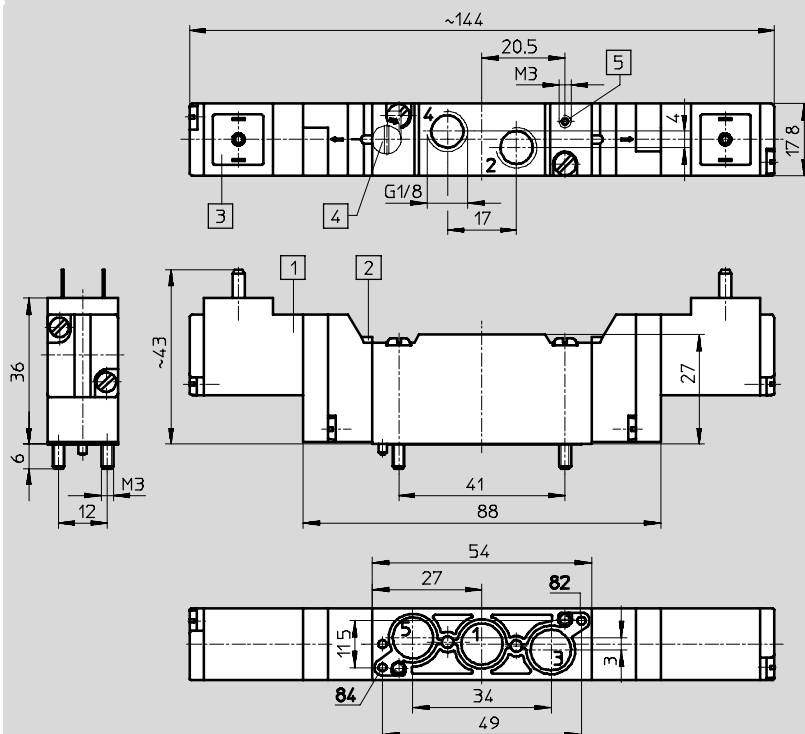

- 1) Solenoid coil can be rotated 180°¹⁾
 - 2) Manual override
 - 3) Suitable for terminal sockets to DIN 46 247 or plug sockets MSSD-E type KME type
 - 4) Manual override tool (accessory) AHB-ME-1/8
 - 5) Port for external pilot air on S types
- 1) The seal must not be turned!

Solenoid valves MEH, midi pneumatics

Technical data – 5/2-way valves, double solenoid



Dimensions

Download CAD data → www.festo.com/en/engineering

Sub-base valve

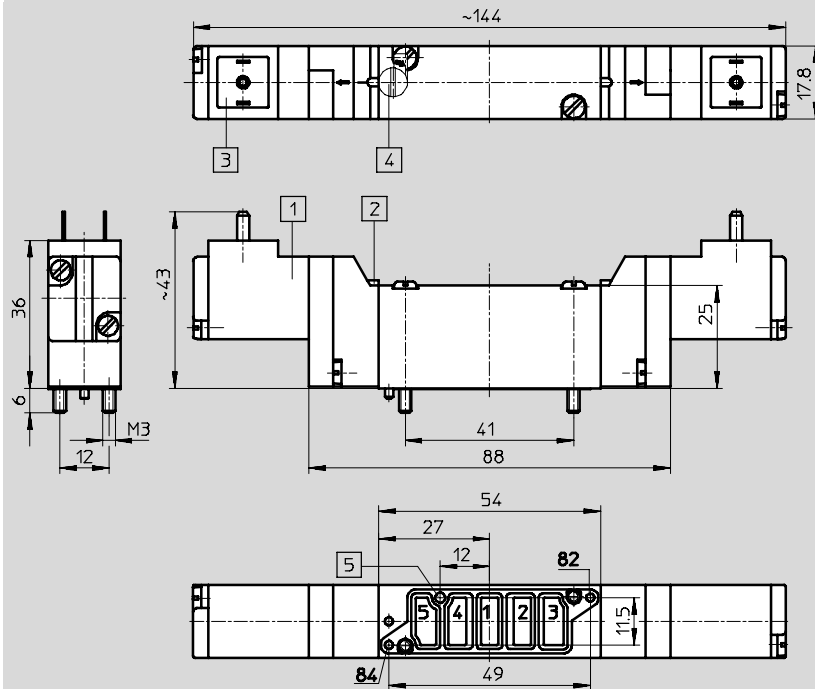

- 1 Solenoid coil can be rotated 180°¹⁾
 - 2 Manual override
 - 3 Suitable for terminal sockets to DIN 46 247 or plug sockets MSSD-E type KME type
 - 4 Manual override tool (accessory) AHB-ME-1/8
 - 5 Port for external pilot air on S types
- 1) The seal must not be turned!

Ordering data

Circuit symbol	Description	Voltage	Part No.	Type
5/2-way valves				
Internal pilot air supply				
	Semi in-line valve with thread G1/8	24 V DC	173 431	JMEH-5/2-1/8-B
	Semi in-line valve for manifold PRS-ME		173 433	JMEH-5/2-1/8-P-B
	Sub-base valve		173 432	JMEH-5/2-5,0-B
External pilot air supply				
	Semi in-line valve with thread G1/8	24 V DC	173 434	JMEH-5/2-1/8-S-B
	Semi in-line valve for manifold PRS-ME		173 436	JMEH-5/2-1/8-P-S-B
	Sub-base valve		173 435	JMEH-5/2-5,0-S-B

Directional control valves for standard applications
Midi Pneumatic

2.4

Solenoid valves MEH, midi pneumatics

Technical data – 5/3-way valves

FESTO

Directional control valves for standard applications
Midi Pneumatic

2.4

Dimensions

Download CAD data → www.festo.com/en/engineering

Semi in-line valve with thread G1/8

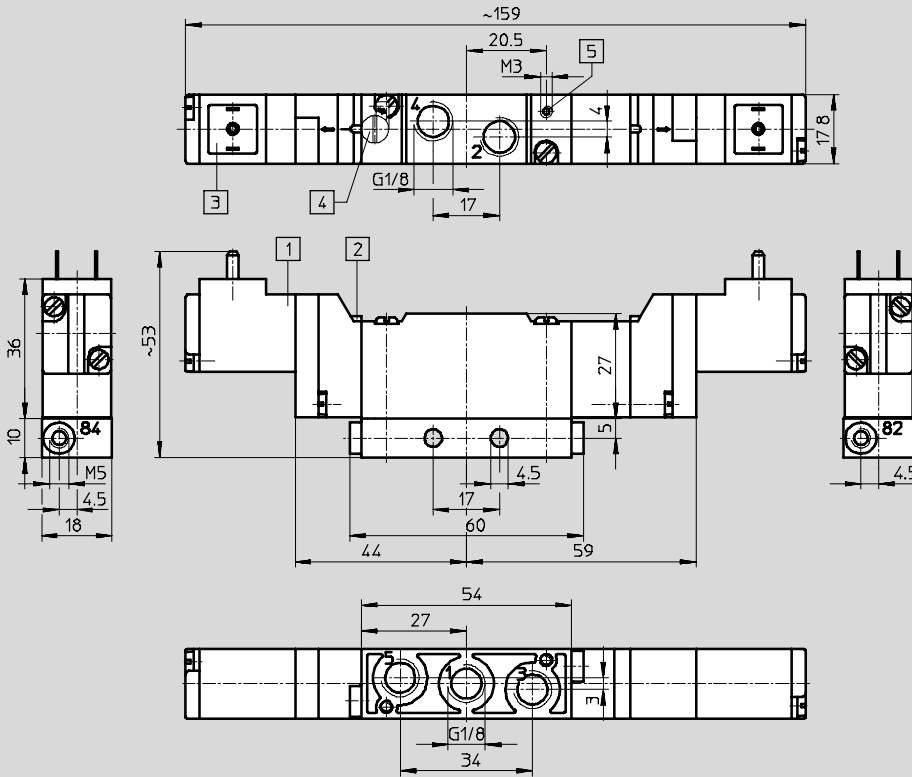

- 1 Solenoid coil can be rotated 180°¹⁾
 - 2 Manual override
 - 3 Suitable for terminal sockets to DIN 46 247 or plug sockets MSSD-E type KME type
 - 4 Manual override tool (accessory) AHB-ME-1/8
 - 5 Port for external pilot air on S types
- 1) The seal must not be turned!

Semi in-line valve for manifold PRS-ME

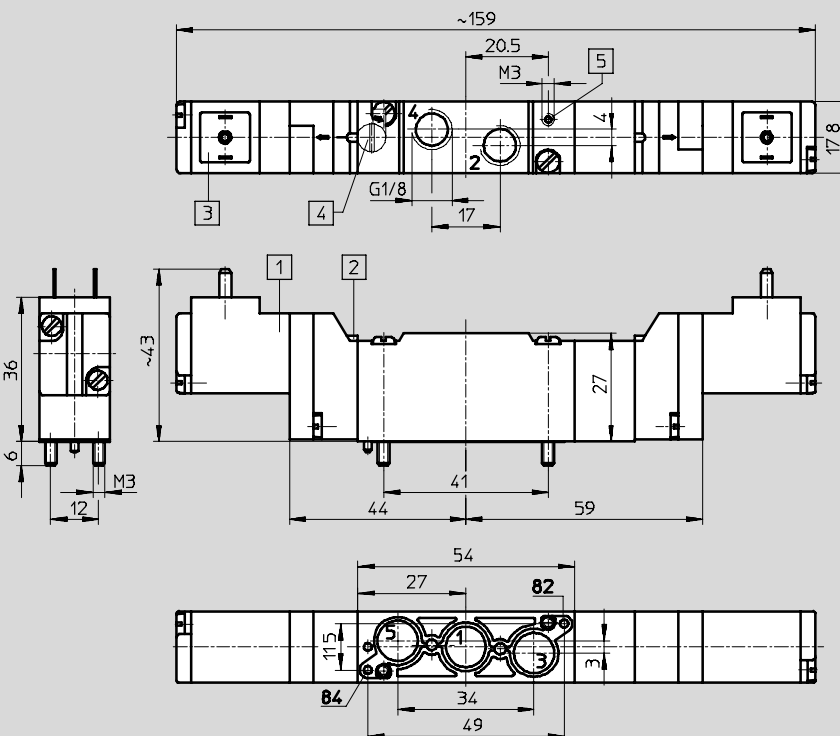

- 1 Solenoid coil can be rotated 180°¹⁾
 - 2 Manual override
 - 3 Suitable for terminal sockets to DIN 46 247 or plug sockets MSSD-E type KME type
 - 4 Manual override tool (accessory) AHB-ME-1/8
 - 5 Port for external pilot air on S types
- 1) The seal must not be turned!

Solenoid valves MEH, midi pneumatics

Technical data – 5/3-way valves

FESTO

Dimensions

Download CAD data → www.festo.com/en/engineering

Sub-base valve

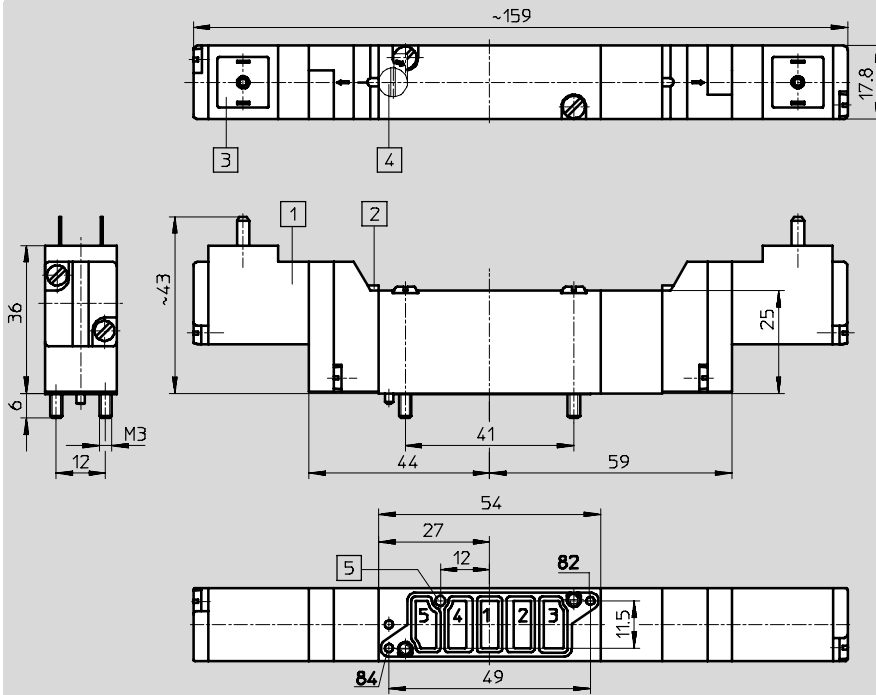

- 1 Solenoid coil can be rotated 180°¹⁾
 - 2 Manual override
 - 3 Suitable for terminal sockets to DIN 46 247 or plug sockets MSSD-E type KME type
 - 4 Manual override tool (accessory) AHB-ME-1/8
 - 5 Port for external pilot air on S types
- 1) The seal must not be turned!

Directional control valves for standard applications
Midi Pneumatic

2.4

Solenoid valves MEH, midi pneumatics

FESTO

Technical data – 5/3-way valves

Directional control valves for standard applications
Midi Pneumatic

2.4

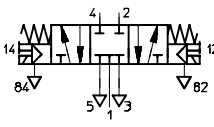
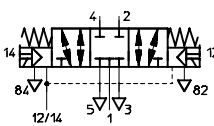
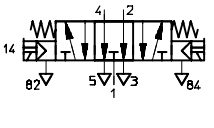
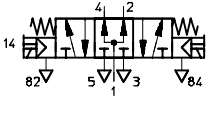
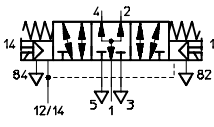
Ordering data				
Circuit symbol	Description	Voltage	Part No.	Type
Normally closed, internal pilot air supply				
	Semi in-line valve with thread G $\frac{1}{8}$	24 V DC	173 139	MEH-5/3G- $\frac{1}{8}$ -B
	Semi in-line valve for manifold PRS-ME		173 141	MEH-5/3G- $\frac{1}{8}$ -P-B
	Sub-base valve		173 140	MEH-5/3G-5,0-B
Normally closed, external pilot air supply				
	Semi in-line valve with thread G $\frac{1}{8}$	24 V DC	173 142	MEH-5/3G- $\frac{1}{8}$ -S-B
	Semi in-line valve for manifold PRS-ME		173 144	MEH-5/3G- $\frac{1}{8}$ -P-S-B
	Sub-base valve		173 143	MEH-5/3G-5,0-S-B
Normally exhausted, internal pilot air supply				
	Semi in-line valve with thread G $\frac{1}{8}$	24 V DC	173 145	MEH-5/3E- $\frac{1}{8}$ -B
	Semi in-line valve for manifold PRS-ME		173 147	MEH-5/3E- $\frac{1}{8}$ -P-B
	Sub-base valve		173 146	MEH-5/3E-5,0-B
Normally exhausted, external pilot air supply				
	Semi in-line valve with thread G $\frac{1}{8}$	24 V DC	173 148	MEH-5/3E- $\frac{1}{8}$ -S-B
	Semi in-line valve for manifold PRS-ME		173 150	MEH-5/3E- $\frac{1}{8}$ -P-S-B
	Sub-base valve		173 149	MEH-5/3E-5,0-S-B
Normally pressurised, internal pilot air supply				
	Semi in-line valve with thread G $\frac{1}{8}$	24 V DC	173 151	MEH-5/3B- $\frac{1}{8}$ -B
	Semi in-line valve for manifold PRS-ME		173 153	MEH-5/3B- $\frac{1}{8}$ -P-B
	Sub-base valve		173 152	MEH-5/3B-5,0-B
Normally pressurised, external pilot air supply				
	Semi in-line valve with thread G $\frac{1}{8}$	24 V DC	173 154	MEH-5/3B- $\frac{1}{8}$ -S-B
	Semi in-line valve for manifold PRS-ME		173 156	MEH-5/3B- $\frac{1}{8}$ -P-S-B
	Sub-base valve		173 155	MEH-5/3B-5,0-S-B

Pneumatic valves VL/J, midi pneumatics

Type codes

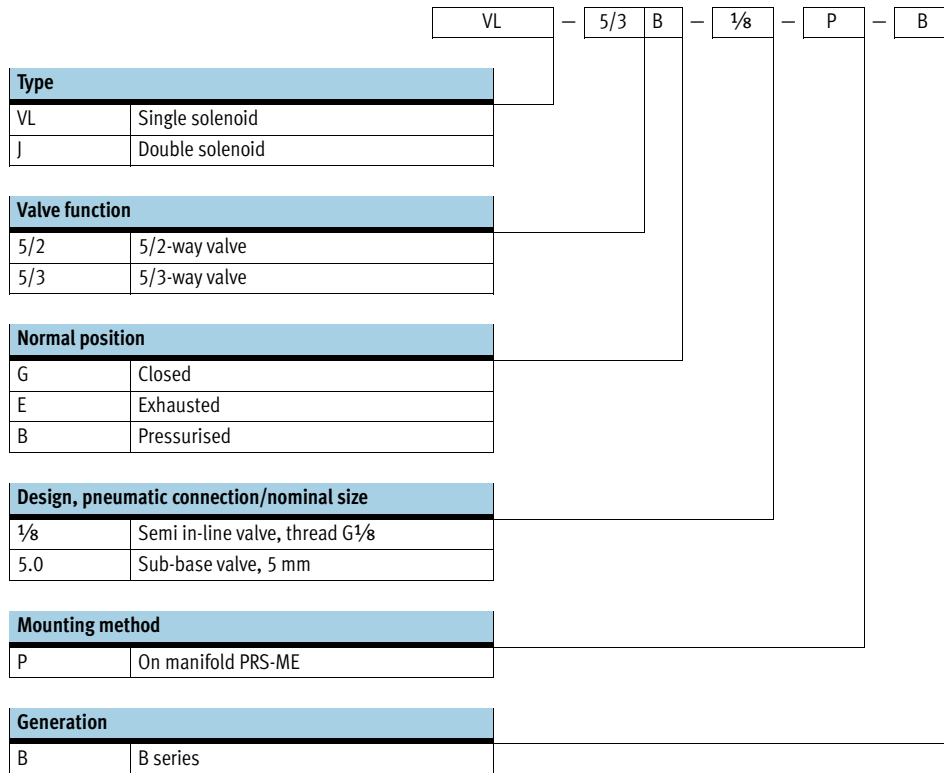

Pneumatic valves VL/J, midi pneumatics

FESTO

Technical data

-  - Flow rate
300 ... 700 l/min

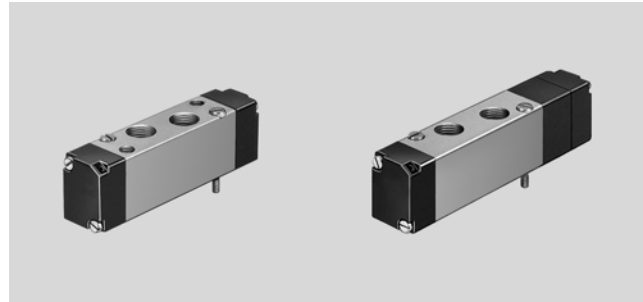

Directional control valves for standard applications
Midi Pneumatic

2.4

General technical data								
Type		VL-5/2-...	J-5/2-...	VL-5/3...				
Design		Piston spool, directly actuated						
Type of mounting	...-1/8	2 through-holes						
	...-5.0	On sub-base with two M3 screws						
	...-1/8-P	On manifold with two M3 screws						
Pneumatic connection	Working lines	...-1/8	G1/8					
		...-5.0	On sub-base					
		...-1/8-P	G1/8					
	Pilot line	M5						
Nominal size	[mm]	5						
Standard nominal flow rate	[l/min]	1 ↔ 2, 1 ↔ 4	...-1/8	600	650	G	E	B
			...-5.0	700	700	500	350	300
			...-1/8-P	600	650	600	350	300
Materials		Housing: Aluminium Seals: Nitrile rubber						
Weight	[g]	...-1/8	75	75	95			
		...-5.0	65	65	85			
		...-1/8-P	60	60	80			

Operating and environmental conditions				
Type		VL-5/2-...	J-5/2-...	VL-5/3...
Operating medium		Filtered compressed air, lubricated or unlubricated ¹⁾ Vacuum		
Operating pressure range	[bar]	-0.9 ... +10		
Pilot pressure range	[bar]	2.5 ... 8	1.5 ... 8	3 ... 8
Ambient temperature	[°C]	-5 ... +50		
Temperature of medium	[°C]	-5 ... +50		

1) Only oils of viscosity class 32 may be used for lubricated operation.

Valve response times [ms]			
Type	VL-5/2-...	J-5/2-...	VL-5/3-...
On	6	-	6
Off	24	-	22
Changeover	-	5	-

Pneumatic valves VL/J, midi pneumatics

Technical data – 5/2-way valves

FESTO

Dimensions

Download CAD data → www.festo.com/en/engineering

Semi in-line valve with thread G1/8

Semi in-line valve for manifold PRS-ME

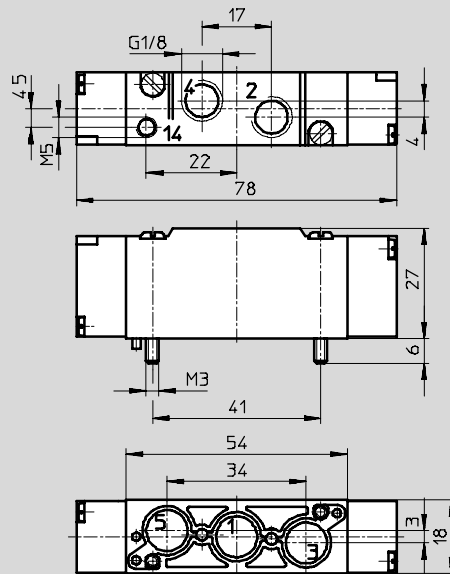
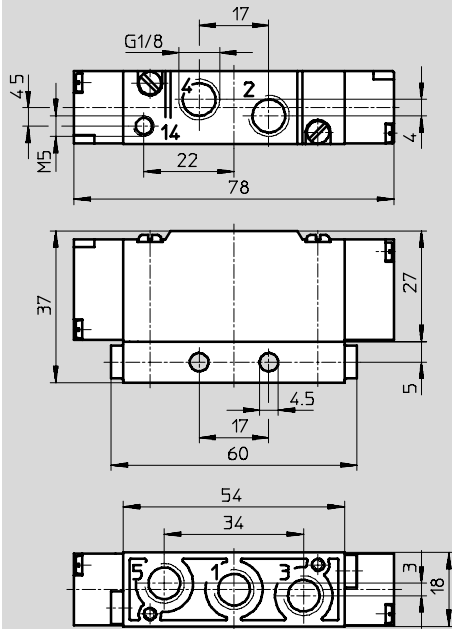

Sub-base valve

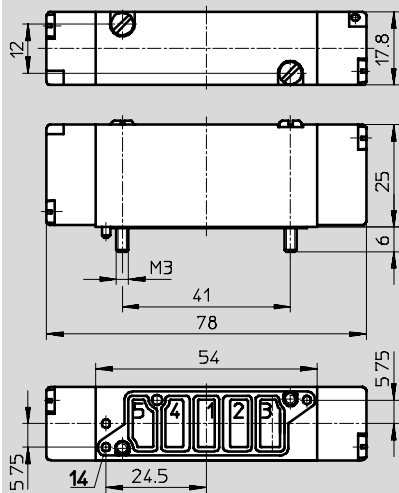

Ordering data

Circuit symbol	Description	Part No.	Type
	Semi in-line valve with thread G1/8	173 168	VL-5/2-1/8-B
	Sub-base valve	173 169	VL-5/2-5,0-B
	Semi in-line valve for manifold PRS-ME	173 170	VL-5/2-1/8-P-B

Directional control valves for standard applications
Midi Pneumatic

2.4

Pneumatic valves VL/J, midi pneumatics

Technical data – 5/2-way valves, double pilot



Directional control valves for standard applications
Midi Pneumatic

2.4

Dimensions

Download CAD data → www.festo.com/en/engineering

Semi in-line valve with thread G $\frac{1}{8}$

Semi in-line valve for manifold PRS-ME

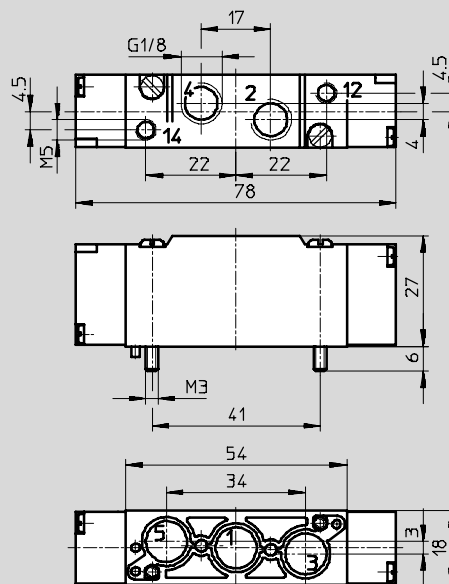
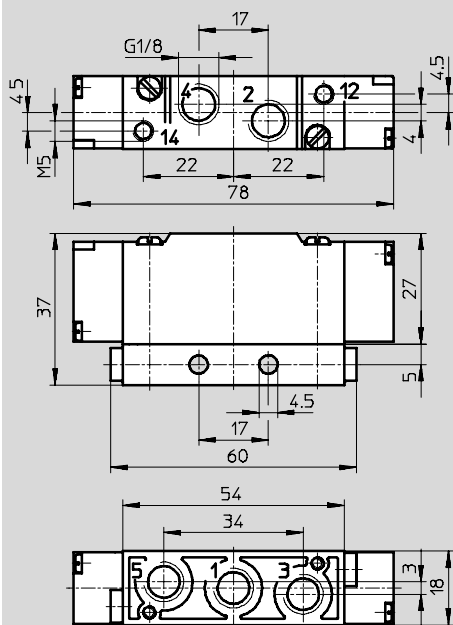

Sub-base valve

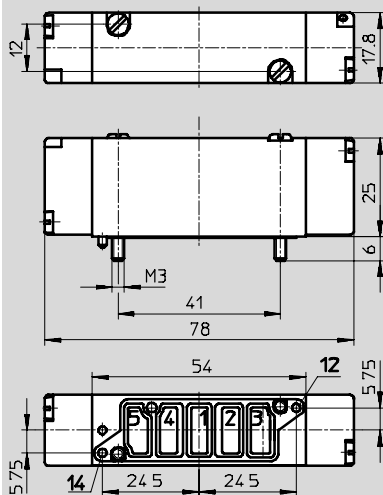

Ordering data

Circuit symbol	Description	Part No.	Type
	Semi in-line valve with thread G $\frac{1}{8}$	173 171	J-5/2- $\frac{1}{8}$ -B
	Sub-base valve	173 172	J-5/2-5,0-B
	Semi in-line valve for manifold PRS-ME	173 173	J-5/2- $\frac{1}{8}$ -P-B

Pneumatic valves VL/J, midi pneumatics



Technical data – 5/3-way valves

Dimensions

Download CAD data → www.festo.com/en/engineering

Semi in-line valve with thread G1/8

Semi in-line valve for manifold PRS-ME

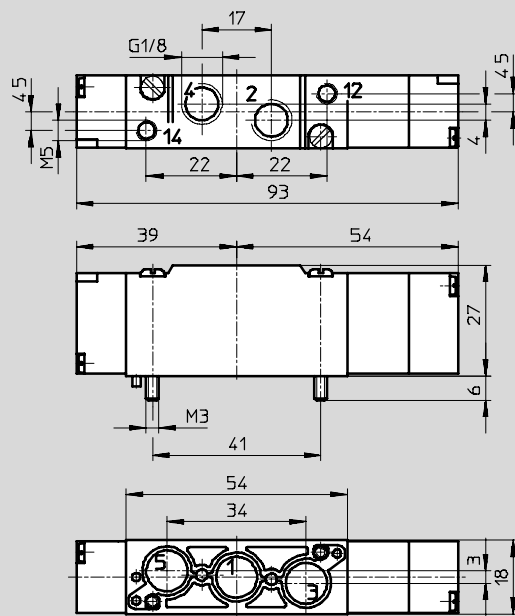
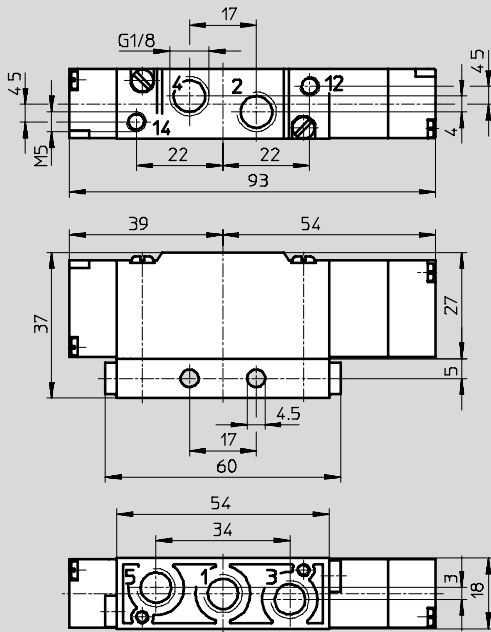

Sub-base valve

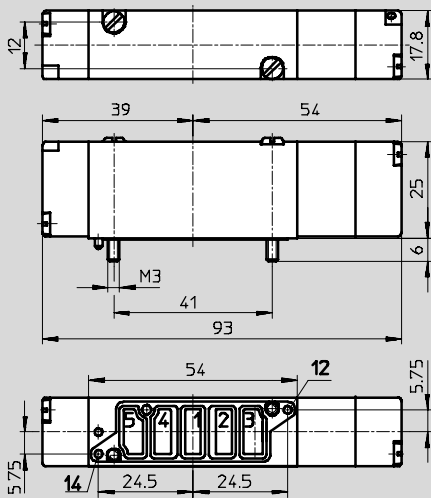

Directional control valves for standard applications
Midi Pneumatic

2.4

Pneumatic valves VL/J, midi pneumatics

Technical data – 5/3-way valves



Directional control valves for standard applications
Midi Pneumatic

2.4

Ordering data			
Circuit symbol	Description	Part No.	Type
Normally closed			
	Semi in-line valve with thread G $\frac{1}{8}$	173 174	VL-5/3G- $\frac{1}{8}$ -B
	Sub-base valve	173 175	VL-5/3G-5,0-B
	Semi in-line valve for manifold PRS-ME	173 176	VL-5/3G- $\frac{1}{8}$ -P-B
Normally exhausted			
	Semi in-line valve with thread G $\frac{1}{8}$	173 177	VL-5/3E- $\frac{1}{8}$ -B
	Sub-base valve	173 178	VL-5/3E-5,0-B
	Semi in-line valve for manifold PRS-ME	173 179	VL-5/3E- $\frac{1}{8}$ -P-B
Normally pressurised			
	Semi in-line valve with thread G $\frac{1}{8}$	173 180	VL-5/3B- $\frac{1}{8}$ -B
	Sub-base valve	173 181	VL-5/3B-5,0-B
	Semi in-line valve for manifold PRS-ME	173 182	VL-5/3B- $\frac{1}{8}$ -P-B

Solenoid/pneumatic valves, midi pneumatics



Accessories

Individual sub-bases
AS, AU

Material:
Die-cast aluminium



Dimensions – Individual sub-bases

Download CAD data → www.festo.com/en/engineering

AS-ME-1/8

AS-VL-1/8

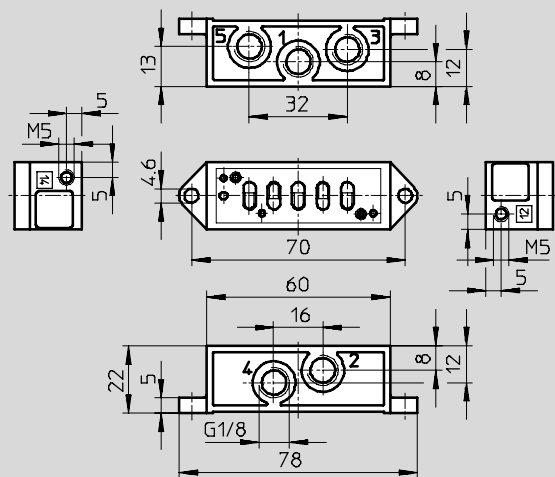
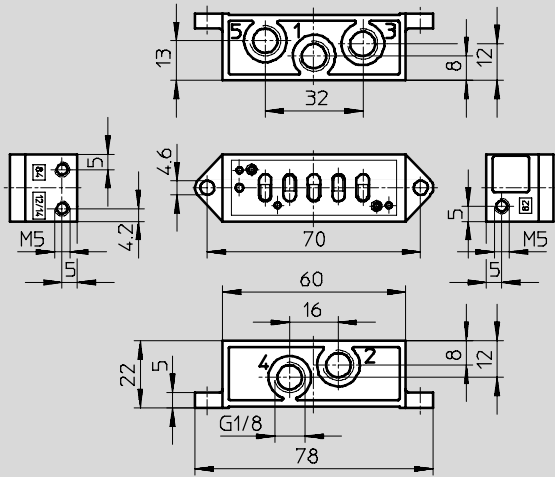

AU-ME-1/8

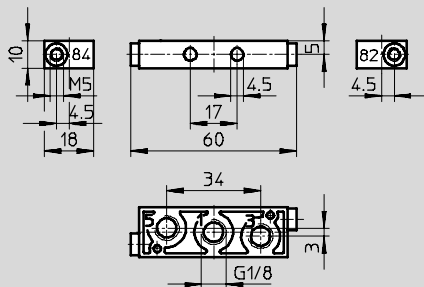

Ordering data

Brief description		Pneumatic connection		Weight [g]	Part No.	Type
		1, 2, 3, 4, 5	82, 84			
For solenoid valves	Connection at side	G1/8	M5	50	33 405	AS-ME-1/8
For pneumatic valves				50		AS-VL-1/8
For valves type ...-1/8-P	Connection underneath			15	32 797	AU-ME-1/8

Directional control valves for standard applications
Midi Pneumatic

2.4

Solenoid/pneumatic valves, midi pneumatics

Accessories



Series sub-bases
AW, EP, ZP

Material:
Die-cast aluminium



Dimensions

Download CAD data → www.festo.com/en/engineering

Manifold mounting

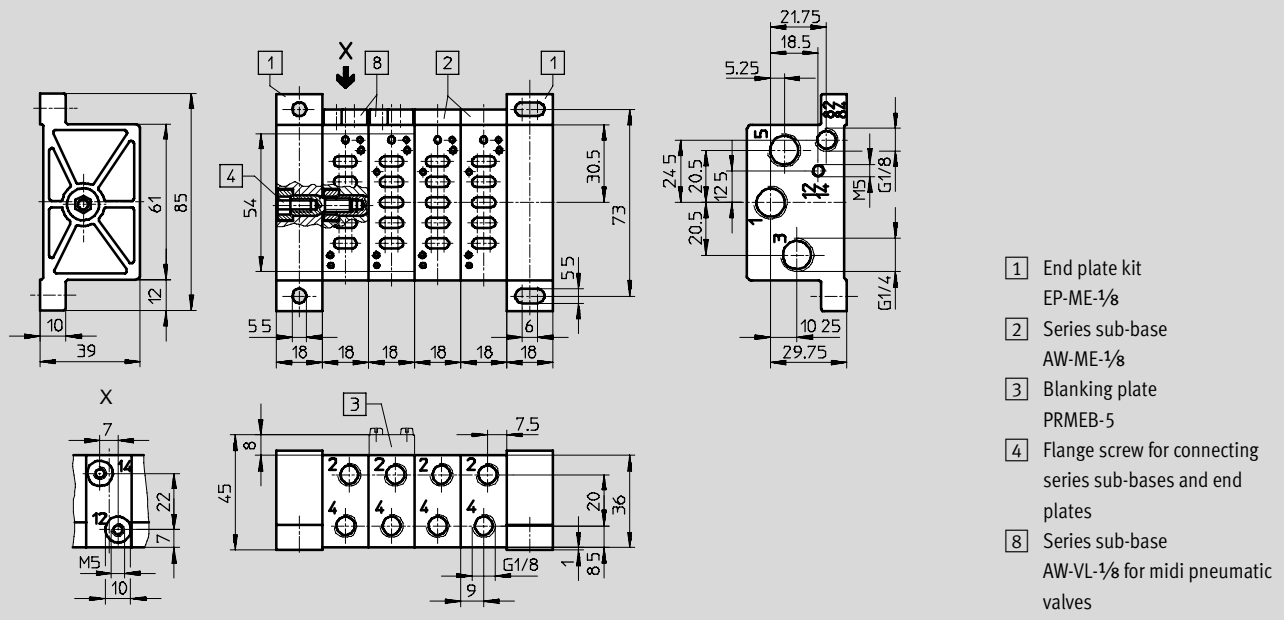

Directional control valves for standard applications
Midi Pneumatic

2.4

Ordering data

Designation	Brief description	Scope of delivery	Weight [g]	Part No.	Type
Series sub-base	For solenoid valves	1 sub-base, seals and fastening screws	75	33 406	AW-ME-1/8
	For pneumatic valves			152 801	AW-VL-1/8
Blanking plate for spare positions	-	-		31 798	PRMEB-5
End plate kit	-	2 end plates, seals and fastening screws	160	33 407	EP-ME-1/8
Intermediate plate	With additional P connection	-	95	152 592	ZP-ME-1/8-P
	With separate P connection to form pressure zones			152 591	ZP-ME-1/8-Z

Solenoid/pneumatic valves, midi pneumatics



Accessories

Manifold PRS-ME

Material:
Die-cast aluminium

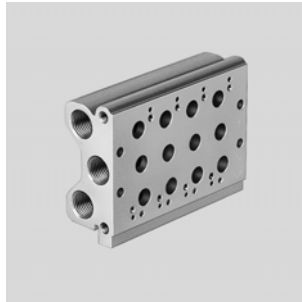

Dimensions

Download CAD data → www.festo.com/en/engineering

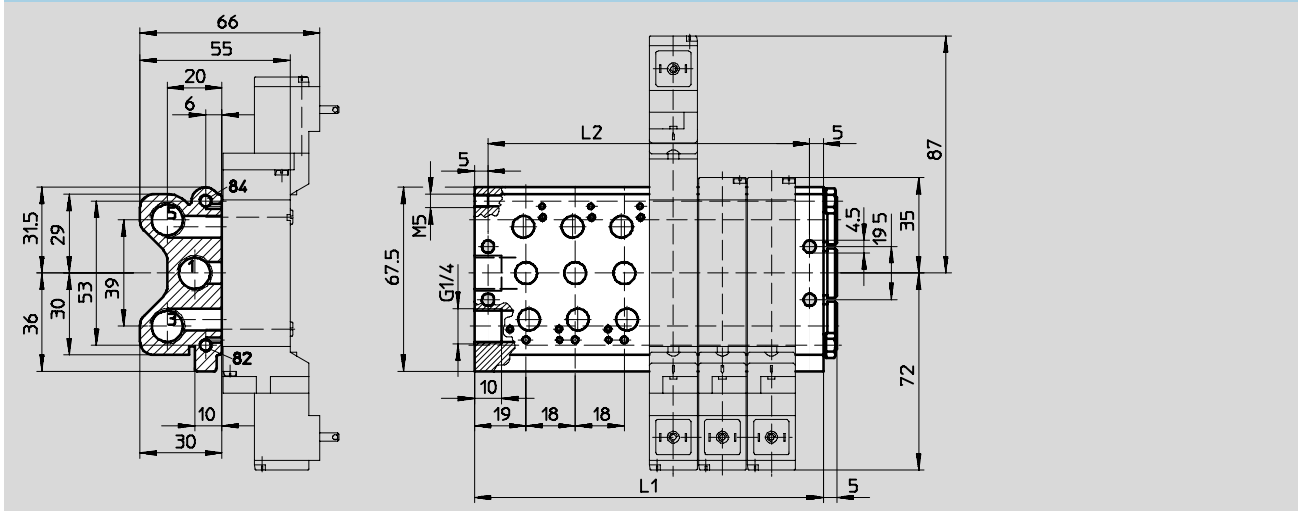

Number of valve positions	L1	L2
2	56	46
3	74	64
4	92	82

Number of valve positions	L1	L2
5	110	100
6	128	118
7	146	136

Number of valve positions	L1	L2
8	164	154
9	182	172
10	200	190

Ordering data – Manifold block

Pneumatic connection			Number of valve positions	Weight [g]	Part No.	Type
1, 3, 5	2, 4	82, 84				
G $\frac{1}{4}$	G $\frac{1}{8}$ on valve	M5	2	200	33 408	PRS-ME- $\frac{1}{8}$ -2
			4	300	33 409	PRS-ME- $\frac{1}{8}$ -4
			6	430	33 410	PRS-ME- $\frac{1}{8}$ -6
			8	540	33 411	PRS-ME- $\frac{1}{8}$ -8
			10	680	33 412	PRS-ME- $\frac{1}{8}$ -10

Ordering data – Blanking plate

Brief description	Part No.	Type
Blanking plate for spare positions	31 799	PRSB-ME- $\frac{1}{8}$

- - Note

For combined assembly of series sub-bases
AW-ME- $\frac{1}{8}$ and AW-VL- $\frac{1}{8}$, the following assembly sequence must be observed:

1. End plate with air supply
2. Series sub-bases for solenoid valves
3. Series sub-bases for pneumatic valves
4. End plate with flange screw



Solenoid/pneumatic valves, midi pneumatics





Accessories

FESTO

Directional control valves for standard applications
Midi Pneumatic

2.4

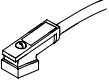

Ordering data		
	Brief description	Part No. Type
Push-in/threaded fittings QS		
	–	→ Volume 3 → www.festo.com
Silencers		
	–	→ Volume 3 → www.festo.com
Manual override tool, detenting		Technical data → NO TAG
Manual override tool, detenting		Technical data → www.festo.com
	For midi valves MEH, MOEH, JMEH	152 797 AHB-ME-1/8 → → www.festo.com www.festo.com

Ordering data – Plug sockets, plug sockets with cable, illuminating seal for EB solenoid coils				
	Voltage	Cable length [m]	Switching status display with LED	Part No. Type
Plug socket without cable				Technical data → NO TAG
Plug socket without cable				Technical data → www.festo.com
	–	–	–	151 687 MSSD-EB
	–	–	–	539 712 MSSD-EB-M12
Plug socket without cable with insulation displacement technology				Technical data → NO TAG
Plug socket without cable with insulation displacement technology				Technical data → www.festo.com
	–	–	–	192 745 MSSD-EB-S-M14
PVC plug socket with cable				Technical data → NO TAG
Plug socket with cable				Technical data → www.festo.com
	24 V DC	2.5	■	151 688 KMEB-1-24-2,5-LED
	24 V DC	5	■	151 689 KMEB-1-24-5-LED
	24 V DC	10	■	193 457 KMEB-1-24-10-LED
	Up to 240 V	2.5	–	151 690 KMEB-1-230AC-2,5
	Up to 240 V	5	–	151 691 KMEB-1-230AC-5
PUR plug socket with cable				Technical data → NO TAG
Plug socket with cable				Technical data → www.festo.com
	24 V DC	2.5	■	174 844 KMEB-2-24-2,5-LED
	24 V DC	5	■	174 845 KMEB-2-24-5-LED
	Up to 240 V	2.5	–	174 846 KMEB-2-230AC-2,5
	Up to 240 V	5	–	174 847 KMEB-2-230AC-5
Illuminating seal				Technical data → NO TAG
Plug socket without cable with insulation displacement technology				Technical data → www.festo.com
	12 ... 24 V DC	–	–	151 717 MEB-LD-12-24DC
	230 V AC	–	–	151 718 MEB-LD-230AC

Solenoid/pneumatic valves, midi pneumatics

Accessories

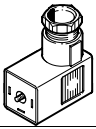
FESTO

Ordering data – Plug sockets, plug sockets with cable, illuminating seal for E solenoid coils					
	Voltage	Cable length [m]	Switching status display with LED	Part No.	Type
Plug socket without cable				Technical data → NO TAG	
Plug socket without cable				Technical data → www.festo.com	
	–	–	–	14 098	MSSD-E
				539 711	MSSD-E-M12
Plug socket with cable				Technical data → NO TAG	
Plug socket with cable				Technical data → www.festo.com	
	24 V DC	2.5	■	30 943	KME-1-24DC-2,5-LED
		5	■	30 945	KME-1-24DC-5-LED
		10	■	193 455	KME-1-24DC-10-LED
Illuminating seal				Technical data → NO TAG	
Plug socket without cable with insulation displacement technology				Technical data → www.festo.com	
	24 V DC	–	–	19 141	ME-LD-12-24DC

Directional control valves for standard applications
Midi Pneumatic

2.4