



- Electrically or pneumatically actuated valves
- With internal or external pilot air
- Sturdy and reliable

Specified types in accordance with ATEX directive for potentially explosive atmospheres
→ www.festo.com/en/ex

Solenoid/pneumatic valves, Tiger Classic



Key features

General information

- Highly durable poppet valve concept for all 3/2 and 5/2-way valves
- Pneumatic or electrical actuation with F solenoid coil
- With flow rates of up to 7,500 l/min
- Pipe thread in sizes G1/8, G1/4, G1/2 and G3/4
- Tried and tested assembly on PAL or PRS manifold strips with hollow bolts
- Optimised response times with patented U-ring and servo control

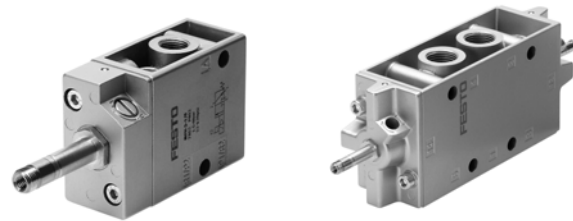

Solenoid coils

F solenoid coils

- | | | | |
|--|---|---|--|
| <p>Voltage:</p> <ul style="list-style-type: none"> ■ 12 to 230 V DC ■ 12 to 240 V AC (50 to 60 Hz) | <p>Power consumption:</p> <ul style="list-style-type: none"> ■ 4.5 W | <ul style="list-style-type: none"> ■ Selected types acc. to ATEX directive for explosive atmospheres | <ul style="list-style-type: none"> ■ Easily interchangeable solenoid coils ■ Solenoid coil not included in scope of delivery |
|--|---|---|--|

Variants

VL/O-3-...	MFH-3-..., MOFH-3-...	MFH-3-...-S
Depending upon selected connections: Normally closed or normally open	<ul style="list-style-type: none"> ■ MFH-3-... Normally closed ■ MOFH-3-... Normally open 	<p>These valves can be converted from one function to the other by rotating the seal under the cover.</p> <p>This valve type can be used within a range of 0 to 8 bar and also as MOFH (through flow when not actuated) with a separate pilot line.</p>

MFH-5-...-S

The external pilot air connection means that these valves can also be used with low operating pressures.

Solenoid/pneumatic valves, Tiger Classic



Key features

Manifold mounting

With PAL manifold strip



With PRS manifold block



The Tiger Classic valves can be mounted on PAL manifold strips with common supply port or on PRS manifold blocks with common supply port and common exhausts. The valves are mounted on the strips and blocks with hollow bolts. The manifold strip and manifold block have 2 to 6 valve positions.

Vacant positions can be sealed on PAL manifold strips with blanking caps, or with blanking plates on PRS manifold blocks.

Separate pressure levels can be provided to individual valves by means of hollow bolts with threaded connection.

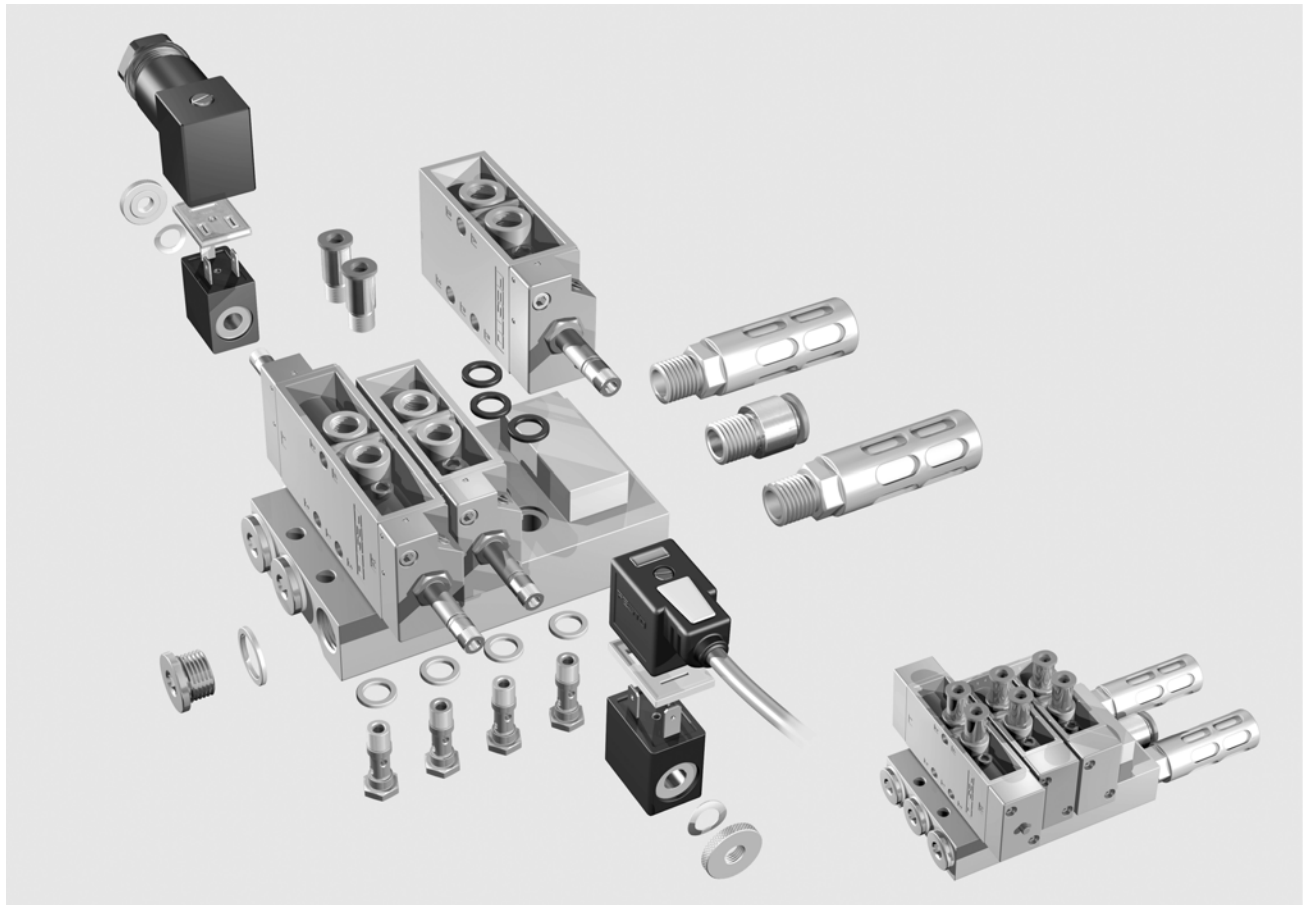

4. Solenoid valves, Tiger Classic



Product range overview

Directional control valves for standard applications
Tiger Classic

2.3

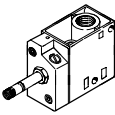
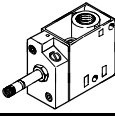
Function	Design	Type	Pneumatic connection	Operating voltage	
				[V DC]	[V AC]
3/2-way valves	Solenoid valve				
		MFH	G1/8	12, 24, 42, 48	24, 42, 48, 110, 230, 240
			G1/4		
			G1/2		
			G3/4		
		MOFH	G1/8	12, 24, 42, 48	24, 42, 48, 110, 230, 240
			G1/4		
			G1/2		
G3/4					

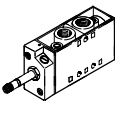
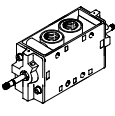
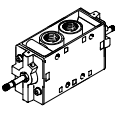
Function	Design	Type	Pneumatic connection	Operating voltage		
				[V DC]	[V AC]	
5/2-way valves	Solenoid valve					
		MFH	G1/8	12, 24, 42, 48	24, 42, 48, 110, 230, 240	
			G1/4			
			G1/2			
	Double solenoid valve					
		JMFH	G1/8	12, 24, 42, 48	24, 42, 48, 110, 230, 240	
			G1/4			
			G1/2			
	Double solenoid valve with dominant signal					
		JMFDH	G1/8	12, 24, 42, 48	24, 42, 48, 110, 230, 240	
G1/4						

5.Solenoid valves, Tiger Classic

Product range overview

Type	Normal position		Pilot air supply		Type of reset		→ Page
	Closed	Open	Internal	External	Air spring	Mechanical spring	
Solenoid valve							
MFH	■	-	■	■	-	■	2 / 2.3-12
	■	-	■	■	-	■	
	■	-	■	■	-	■	
	■	-	■	■	-	■	
MOFH	-	■	■	-	-	■	2 / 2.3-12
	-	■	■	-	-	■	
	-	■	■	-	-	■	
	-	■	■	-	-	■	

Type	Pilot air supply		Type of reset		→ Page
	Internal	External	Air spring	Mechanical spring	
Solenoid valve					
MFH	■	■	-	■	2 / 2.3-17
	■	■	-	■	
	■	■	-	■	
Double solenoid valve					
JMFH	■	■	-	-	2 / 2.3-22
	■	■	-	-	
	■	■	-	-	
Double solenoid valve with dominant signal					
JMFDH	-	■	-	-	2 / 2.3-22
	-	■	-	-	

6. Pneumatic valves, Tiger Classic

Product range overview

Directional control valves for standard applications
Tiger Classic

2.3

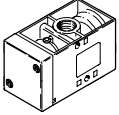
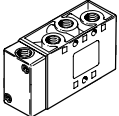
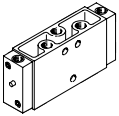
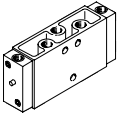
Function	Design	Type	Pneumatic connection	Type of reset		→ Page
				Air spring	Mechanical spring	
3/2-way valves	Pneumatic valve					
		VL/O	G1/8	-	■	2 / 2.3-29
			G1/4	-	■	
			G1/2	-	■	
			G3/4	-	■	
5/2-way valves	Pneumatic valve					
		VL	G1/8	-	■	2 / 2.3-33
			G1/4	-	■	
			G1/2	-	■	
	Double pilot valve					
		JH	G1/8	-	-	2 / 2.3-36
			G1/4	-	-	
			G1/2	-	-	
	Double pilot valve with dominant signal					
		JDH	G1/8	-	-	2 / 2.3-36
G1/4			-	-		

7.Solenoid valves, Tiger Classic

Type codes

FESTO

		MFH	-	5	-	1/8	-	
Type								
MFH	Single solenoid, for F solenoid coil, normally closed							
MOFH	Single solenoid, for F solenoid coil, normally open							
JMFH	Double solenoid, for F solenoid coil							
JMFDH	Double solenoid, for F solenoid coil, with dominant signal							
Valve function								
3	3/2-way valve							
5	5/2-way valve							
Pneumatic connection								
1/8	G1/8							
1/4	G1/4							
1/2	G1/2							
3/4	G3/4							
Pilot air supply								
	Internal							
S	External							

Solenoid valves, Tiger Classic

Peripherals overview



Mounting on manifold block

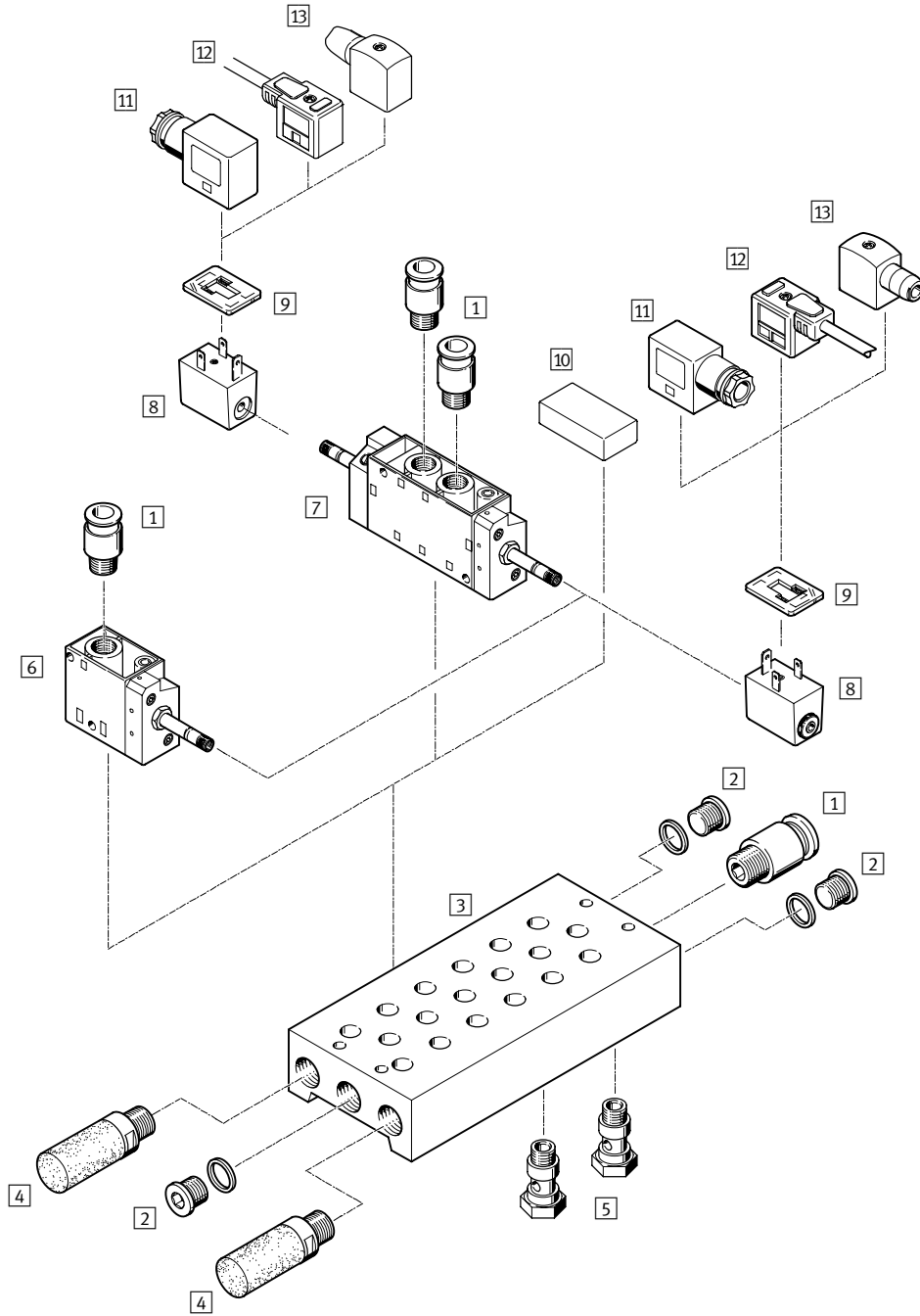

Variants

MFH-5-...

JMFH-5-...

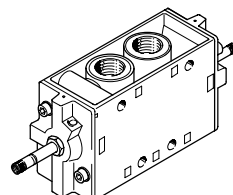
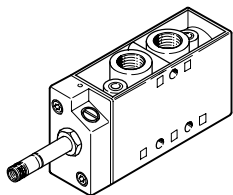

Directional control valves for standard applications
Tiger Classic

2.3

Solenoid valves, Tiger Classic

Peripherals overview

Accessories		
	Brief description	→ Page
1	Push-in fitting QS	Volume 3 www.festo.com
2	Blanking plug G	Volume 3
3	Manifold block PRS	2 / 2.3-42 www.festo.com
4	Silencer	Volume 3 www.festo.com
5	Hollow bolt VT	2 / 2.3-41
6	Solenoid valve MFH	2 / 2.3-4
7	Double solenoid valve JMFH	2 / 2.3-4
8	F solenoid coil MSFG, MSFW	2 / 2.3-44
9	Luminescent seal M...-LD	2 / 2.3-45
10	Blanking plate PRSB	2 / 2.3-43
11	Plug socket MSSD-F	2 / 2.3-45
12	Plug socket with cable KMF	2 / 2.3-45
13	Plug socket MSSD-F-S	2 / 2.3-45

Solenoid valves, Tiger Classic

Peripherals overview



Directional control valves for standard applications
Tiger Classic

2.3

Mounting on manifold strip

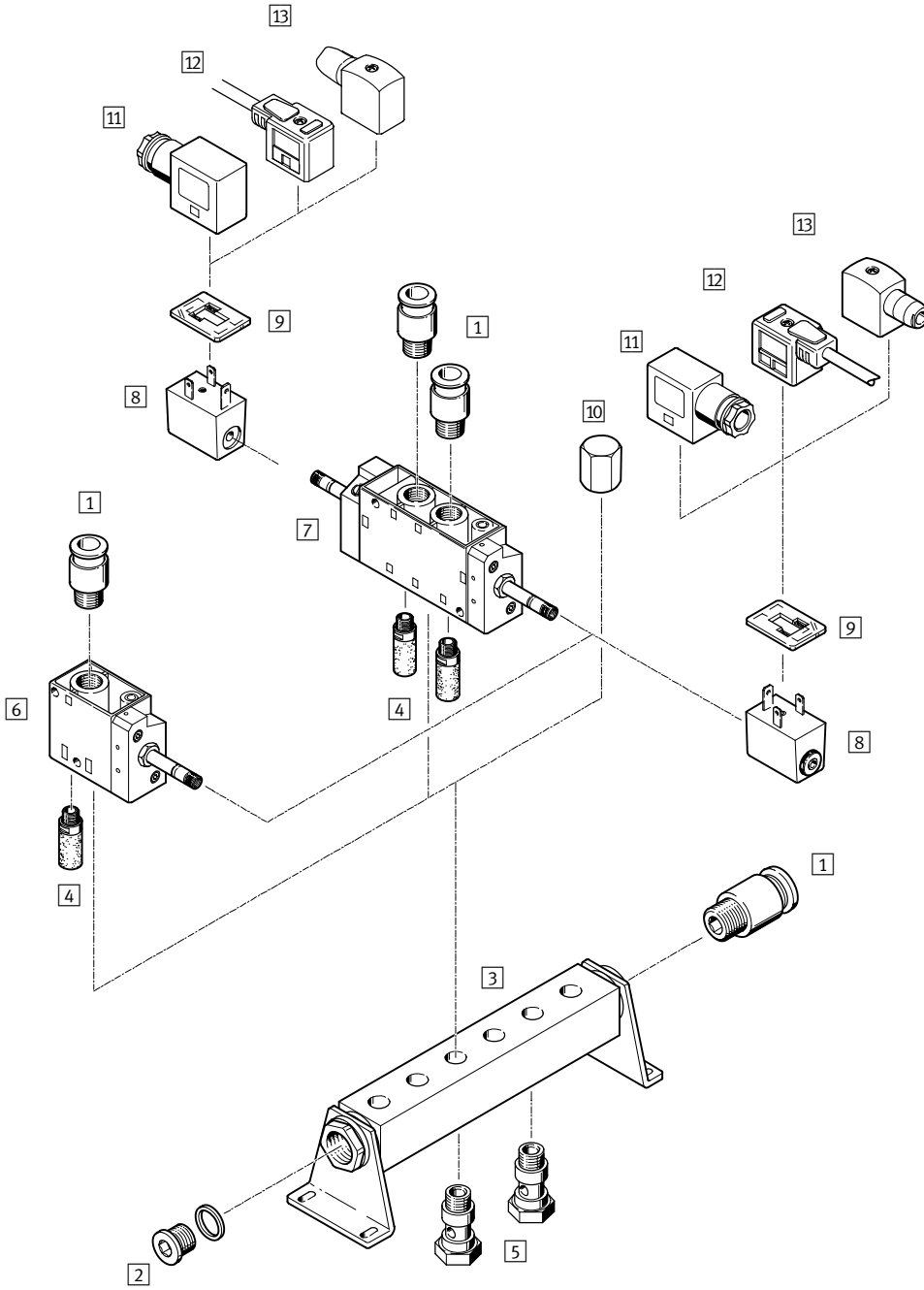

Variants

MFH-5-...

JMFH-5-...

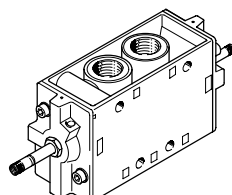
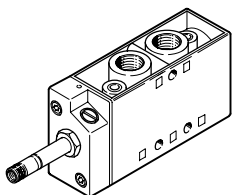

Solenoid valves, Tiger Classic



Peripherals overview

Accessories		
	Brief description	→ Page
1	Push-in fitting QS	Volume 3 www.festo.com
2	Blanking plug G	Volume 3
3	Manifold strip PAL	2 / 2.3-40 www.festo.com
4	Silencer	Volume 3 www.festo.com
5	Hollow bolt VT	2 / 2.3-41
6	Solenoid valve MFH	2 / 2.3-4
7	Double solenoid valve JMFH	2 / 2.3-4
8	F solenoid coil MSFG, MSFW	2 / 2.3-44
9	Luminescent seal M...-LD	2 / 2.3-45
10	Blanking cap VTM	2 / 2.3-41
11	Plug socket MSSD-F	2 / 2.3-45
12	Plug socket with cable KMF	2 / 2.3-45
13	Plug socket MSSD-F-S	2 / 2.3-45

Solenoid valves MFH, Tiger Classic

Technical data – 3/2-way valves



-  - Flow rate
500 ... 7,500 l/min
-  - Voltage
12, 24, 42, 48 V DC
24, 42, 48, 110, 230,
240 V AC
- Wearing parts kits
➔ 2 / 2.3-16



Directional control valves for standard applications
Tiger Classic

2.3

General technical data					
Pneumatic connection	G1/8	G1/4	G1/2	G3/4	
Valve function	3/2-way, single solenoid				
Constructional design	Poppet valve				
Sealing principle	Soft				
Actuation type	Electrical				
Type of reset	Mechanical spring				
Type of control	Piloted				
Pilot air supply	Internal or external				
Direction of flow	Non reversible				
Exhaust function	With flow control				
Manual override	Detenting				
Type of mounting	Via through holes				
Mounting position	Any				
Nominal size	[mm]	5	7	14	19
Standard nominal flow rate	[l/min]	500	800	3,700	7,500
Product weight	[g]	240	320	1,100	1,260

Operating and environmental conditions					
Pneumatic connection	G1/8	G1/4	G1/2	G3/4	
Operating medium	Filtered compressed air, lubricated or unlubricated Vacuum				
Operating pressure	Internal pilot air supply [bar]	1.5 ... 8	1.5 ... 8	1.5 ... 8	2 ... 8
	External pilot air supply [bar]	-0.95 ... +10	-0.95 ... +10	-0.95 ... +10	-0.95 ... +10
Pilot pressure	[bar]	1 ... 8	1 ... 8	1 ... 8	1 ... 8
Ambient temperature	[°C]	-5 ... +40			
Temperature of medium	[°C]	-10 ... +60			

Solenoid valves MFH, Tiger Classic

Technical data – 3/2-way valves



Minimal pilot pressure p_{12}/p_{14} as a function of operating pressure p_1 (external pilot air supply)

MFH-5-1/8-S

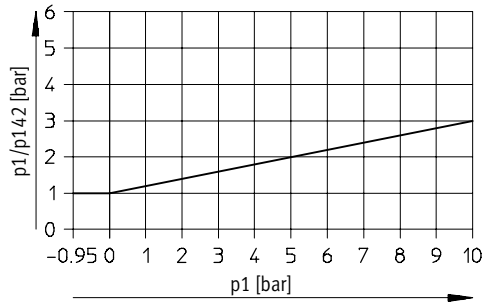

MFH-5-1/4-S

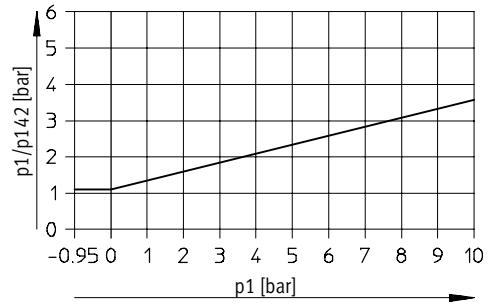

MFH-5-1/2-S

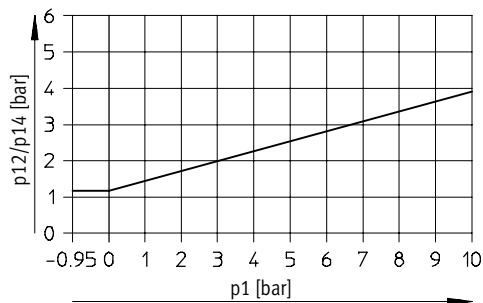

MFH-5-3/4-S

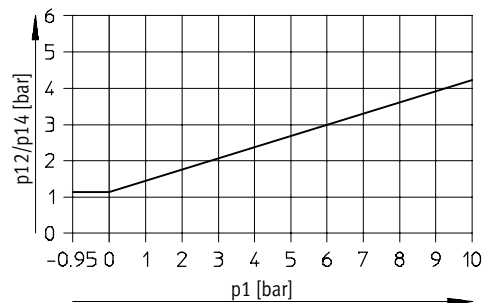

Valve response times [ms]

Pneumatic connection	G1/8		G1/4		G1/2		G3/4	
Normal position	Closed	Open	Closed	Open	Closed	Open	Closed	Open
Internal pilot air supply								
On	9	9	10	15	18	18	40	40
Off	29	29	29	45	90	90	29	29
External pilot air supply								
On	9	–	10	–	18	–	40	–
Off	29	–	29	–	90	–	29	–

Solenoid valves MFH, Tiger Classic

FESTO

Technical data – 3/2-way valves

Electrical data			
F solenoid coil			
Electrical connection		Plug vanes for plug sockets MSSD-F, KMF	
Operating voltage	D.C. voltage	[V DC]	12, 24, 42, 48
	A.C. voltage	[V AC]	24, 42, 48, 110, 230, 240 (50 ... 60 Hz)
Coil characteristics	D.C. voltage	[W]	4.5
	A.C. voltage	[VA]	Pull: 7.5 Hold: 6
Protection class to EN 60 529			IP65 (in combination with plug socket)

Materials

Sectional view

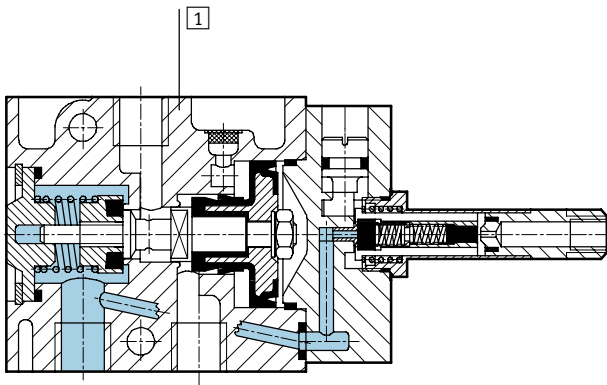

1	Housing	Aluminium die-cast, anodised
-	Seals	Nitrile rubber

Solenoid valves MFH, Tiger Classic

Technical data – 3/2-way valves



Dimensions

Download CAD data → www.festo.com/en/engineering

MFH, MOFH

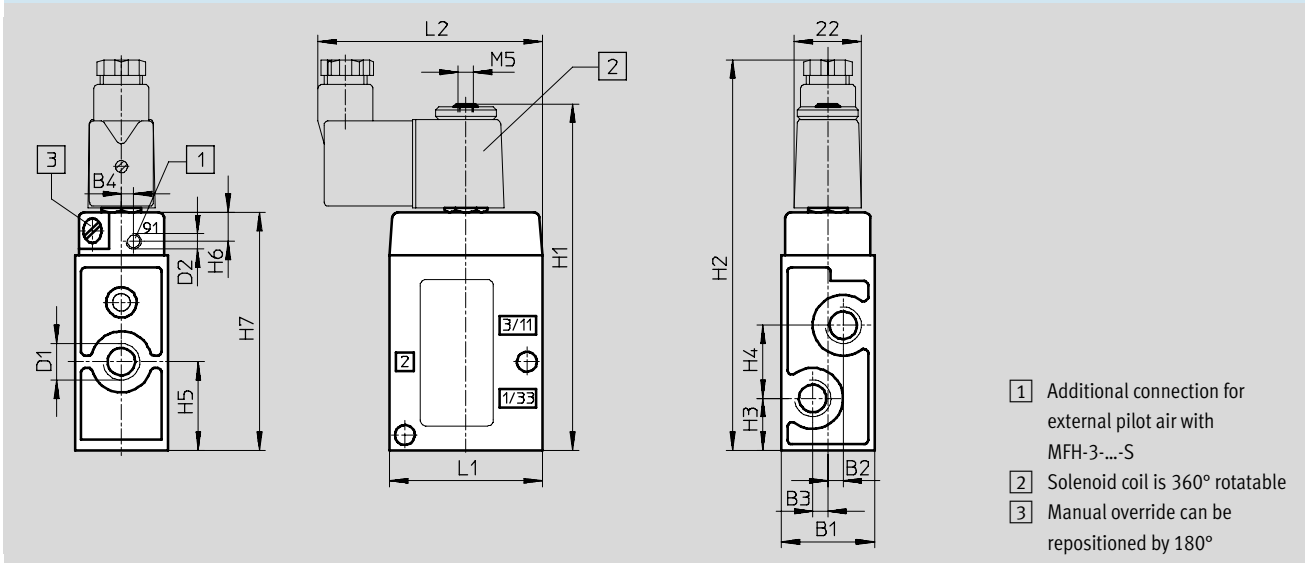

Pneumatic connection	B1	B2	B3	B4	D1	D2	H1	H2	H3	H4	H5	H6	H7	L1	L2
G1/8	26	3.5	3.5	2.7	G1/8	M5	97	111	12.5	19	22	9.5	63	45	71
G1/4	30.4	5	5	4	G1/4	M5	112	126	17	24	29	9.5	78	50	74
G1/2	52	8	8	-	G1/2	G1/8	151	165	30	38	49	10.5	117	80	89
G3/4	68	8	8	-	G3/4	G1/8	171	185	34	44	56	11	137	92	95

Attachment diagram

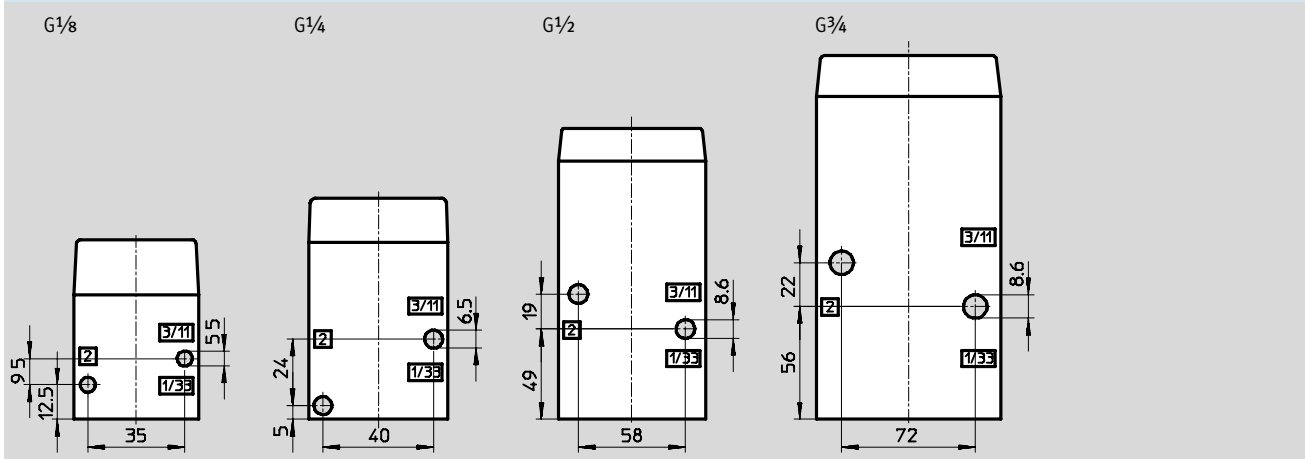

Solenoid valves MFH, Tiger Classic



Technical data – 3/2-way valves

Ordering data				
Circuit symbol	Description	Pneumatic connection	Part No.	Type
	Without F solenoid coil ¹⁾ , internal pilot air supply	G $\frac{1}{8}$	7 802	MFH-3-$\frac{1}{8}$
		G $\frac{1}{4}$	9 964	MFH-3-$\frac{1}{4}$
		G $\frac{1}{2}$	9 857	MFH-3-$\frac{1}{2}$
		G $\frac{3}{4}$	11 967	MFH-3-$\frac{3}{4}$
	Without F solenoid coil ¹⁾ , internal pilot air supply	G $\frac{1}{8}$	7 877	MOFH-3-$\frac{1}{8}$
		G $\frac{1}{4}$	7 876	MOFH-3-$\frac{1}{4}$
		G $\frac{1}{2}$	7 884	MOFH-3-$\frac{1}{2}$
		G $\frac{3}{4}$	11 969	MOFH-3-$\frac{3}{4}$
	Without F solenoid coil ¹⁾ , external pilot air supply	G $\frac{1}{8}$	7 958	MFH-3-$\frac{1}{8}$-S
		G $\frac{1}{4}$	7 959	MFH-3-$\frac{1}{4}$-S
		G $\frac{1}{2}$	7 960	MFH-3-$\frac{1}{2}$-S
		G $\frac{3}{4}$	11 968	MFH-3-$\frac{3}{4}$-S

1) F solenoid coils → 2 / 2.3-44

Ordering data – Wearing parts kits		
Pneumatic connection	Part No.	Type
G $\frac{1}{8}$	104 206	MFH-3-$\frac{1}{8}$
G $\frac{1}{4}$	104 207	MFH-3-$\frac{1}{4}$
G $\frac{1}{2}$	104 208	MFH-3-$\frac{1}{2}$

Solenoid valves MFH, Tiger Classic

FESTO

Technical data – 5/2-way valves

-  - Flow rate
500 ... 3,700 l/min

-  - Voltage
12, 24, 42, 48 V DC
24, 42, 48, 110, 230,
240 V AC

Wearing parts kits
→ 2 / 2.3-21



General technical data				
Pneumatic connection		G1/8	G1/4	G1/2
Valve function		5/2-way, single solenoid		
Constructional design		Poppet valve		
Sealing principle		Soft		
Actuation type		Electrical		
Type of reset		Mechanical spring		
Type of control		Piloted		
Direction of flow		Non reversible		
Pilot air supply		Internal or external		
Exhaust function		With flow control		
Manual override		Detenting		
Type of mounting		Via through holes		
Mounting position		Any		
Nominal size	[mm]	5	7	14
Standard nominal flow rate	[l/min]	500	1,000	3,700
Product weight	[g]	270	290	1,135

Operating and environmental conditions					
Pneumatic connection		G1/8	G1/4	G1/2	
Operating medium		Filtered compressed air, lubricated or unlubricated			
Operating pressure	Internal pilot air supply	[bar]	1.8 ... 8	2.2 ... 8	2 ... 8
	External pilot air supply	[bar]	0 ... 10	0 ... 8	0 ... 8
Pilot pressure	[bar]	1 ... 8	1.5 ... 8	1.5 ... 8	
Ambient temperature	[°C]	-5 ... +40			
Temperature of medium	[°C]	-10 ... +60			

Directional control valves for standard applications
Tiger Classic

2.3

Solenoid valves MFH, Tiger Classic

Technical data – 5/2-way valves



Minimal pilot pressure p12, p14 as a function of operating pressure p1 (external pilot air supply)

MFH-5-1/8-S

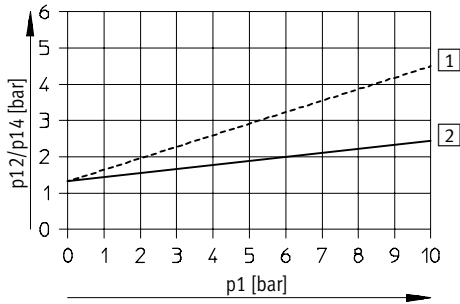

----- Exhaust throttled
 _____ Exhaust unthrottled

MFH-5-1/4-S

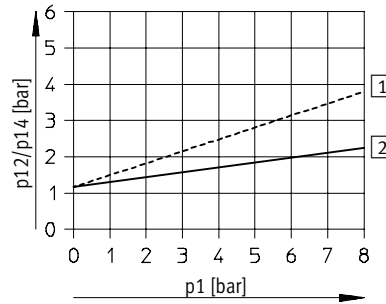

----- Exhaust throttled
 _____ Exhaust unthrottled

MFH-5-1/2-S

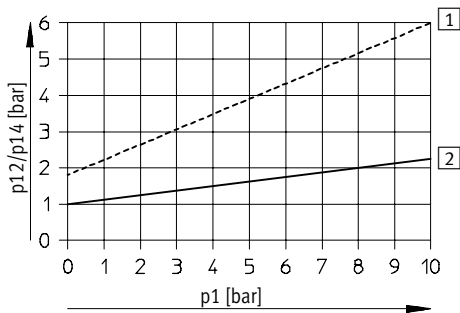

----- Exhaust throttled
 _____ Exhaust unthrottled

Valve response times [ms]

Pneumatic connection	G1/8		G1/4		G1/2	
Pilot air supply	Internal	External	Internal	External	Internal	External
On	8	8	9	9	15	21
Off	36	36	29	29	154	150

Solenoid valves MFH, Tiger Classic

Technical data – 5/2-way valves

Electrical data			
F solenoid coil			
Electrical connection		Plug vanes for plug sockets MSSD-F, KMF	
Operating voltage	D.C. voltage	[V DC]	12, 24, 42, 48
	A.C. voltage	[V AC]	24, 42, 48, 110, 230, 240 (50 ... 60 Hz)
Coil characteristics	D.C. voltage	[W]	4.5
	A.C. voltage	[VA]	Pull: 7.5 Hold: 6
Protection class to EN 60 529		IP65 (in combination with plug socket)	

Materials

Sectional view

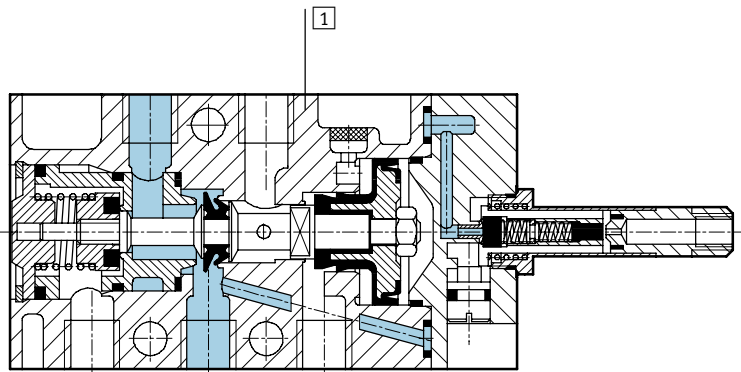

1	Housing	Aluminium die-cast, anodised
-	Seals	Nitrile rubber

Solenoid valves MFH, Tiger Classic

Technical data – 5/2-way valves



Directional control valves for standard applications
Tiger Classic

2.3

Dimensions

Download CAD data → www.festo.com/en/engineering

MFH

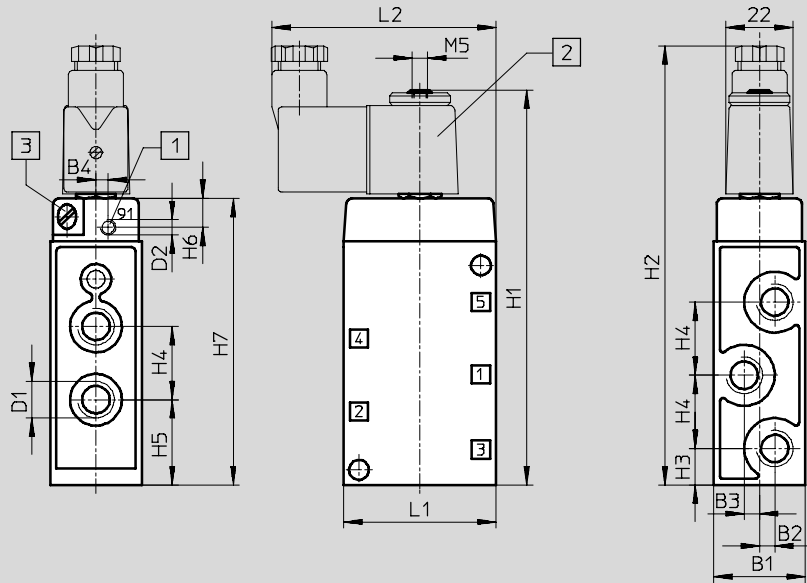

- 1 Additional connection for external pilot air with MFH-5...-S
- 2 Solenoid coil is 360° rotatable
- 3 Manual override can be repositioned by 180°

Pneumatic connection	B1	B2	B3	B4	D1	D2	H1	H2	H3	H4	H5	H6	H7	L1	L2
G $\frac{1}{8}$	26	3.5	3.5	2.7	G $\frac{1}{8}$	M5	117	131	13.5	19	23	9.5	83	45	71
G $\frac{1}{4}$	30.4	-	5	4	G $\frac{1}{4}$	M5	128	143	12	24	28	9.5	128	50	74
G $\frac{1}{2}$	52	-	8	-	G $\frac{1}{2}$	G $\frac{1}{8}$	192	209	32	38	51	10.5	158	80	89

Attachment diagram

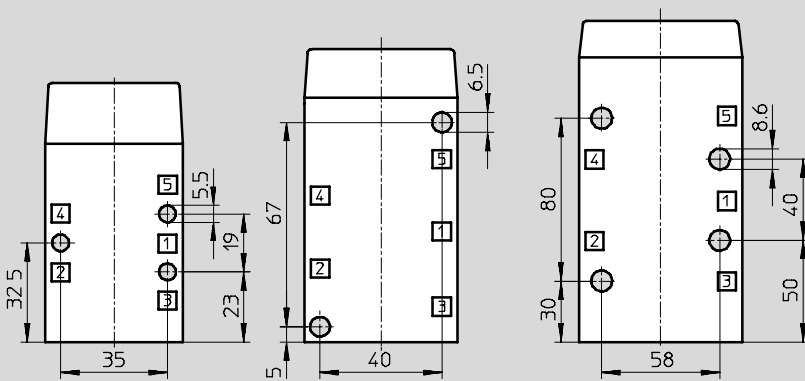

Solenoid valves MFH, Tiger Classic

Technical data – 5/2-way valves

Ordering data				
Circuit symbol	Description	Pneumatic connection	Part No.	Type
	Without F solenoid coil ¹⁾ , internal pilot air supply	G1/8	9 982	MFH-5-1/8
		G1/4	6 211	MFH-5-1/4
		G1/2	6 420	MFH-5-1/2
	Without F solenoid coil ¹⁾ , external pilot air supply	G1/8	10 348	MFH-5-1/8-S
		G1/4	10 349	MFH-5-1/4-S
		G1/2	35 547	MFH-5-1/2-S

1) F solenoid coils → 2 / 2.3-44



Ordering data – Wearing parts kits		
Pneumatic connection	Part No.	Type
G1/8	104 209	MFH-5-1/8 ¹⁾²⁾
G1/4	104 211	MFH-5-1/4 ³⁾⁴⁾

- 1) Order mounting sleeves 228 389 separately
- 2) Use up to E602 series
- 3) Order mounting sleeves 229 363 separately
- 4) Use from 1/81 series

Double solenoid valves JMFH, Tiger Classic

Technical data – 5/2-way double solenoid valves

FESTO

-  - Flow rate
600 ... 4,500 l/min
-  - Voltage
12, 24, 42, 48 V DC
24, 42, 48, 110, 230,
240 V AC
- Wearing parts kits
➔ 2 / 2.3-26

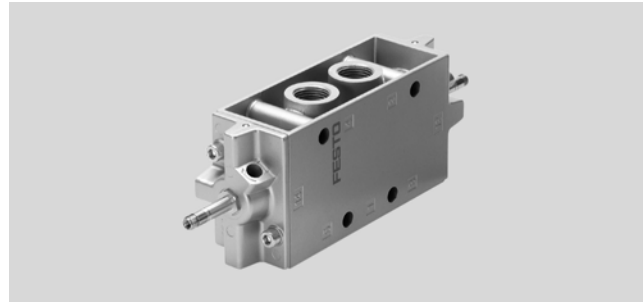

General technical data					
Pneumatic connection		G1/8	G1/4	G1/2	
Valve function		5/2-way, double solenoid			
Constructional design		Poppet valve			
Sealing principle		Soft			
Actuation type		Electrical			
Type of control		Piloted			
Pilot air supply		Internal or external			
Direction of flow		Non reversible			
Exhaust function		With flow control			
Manual override		Detenting			
Type of mounting		Via through holes			
Mounting position		Any			
Nominal size		[mm]	5	7	14
Standard nominal flow rate	Internal pilot air supply	[l/min]	600	1,100	4,500
	External pilot air supply	[l/min]	600	1,100	4,000
Product weight			425	530	1,210

Operating and environmental conditions					
Pneumatic connection		G1/8	G1/4	G1/2	
Operating medium		Filtered compressed air, lubricated or unlubricated			
Operating pressure	Internal pilot air supply	[bar]	1.5 ... 8	1.5 ... 8	2 ... 8
	External pilot air supply	[bar]	0 ... 8	0 ... 8	0 ... 8
	With dominant signal	[bar]	2.5 ... 8	2.5 ... 8	–
Pilot pressure		[bar]	1.2 ... 8	1.2 ... 8	0.5 ... 8
Ambient temperature		[°C]	–5 ... +40		
Temperature of medium		[°C]	–10 ... +60		

Double solenoid valves JMFH, Tiger Classic

Technical data – 5/2-way double solenoid valves

Minimal pilot pressure p12, p14 as a function of operating pressure p1 (external pilot air supply)

JMFH-5-1/8-S

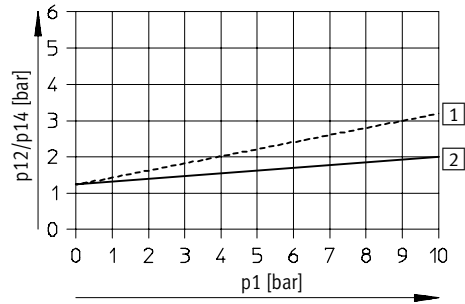

----- Exhaust throttled
 ————— Exhaust unthrottled

JMFH-5-1/4-S

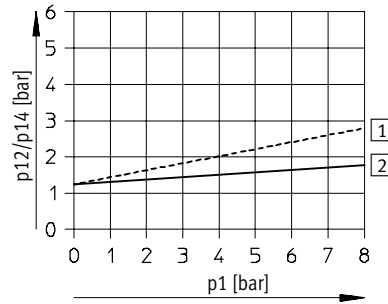

----- Exhaust throttled
 ————— Exhaust unthrottled

JMFH-5-1/2-S

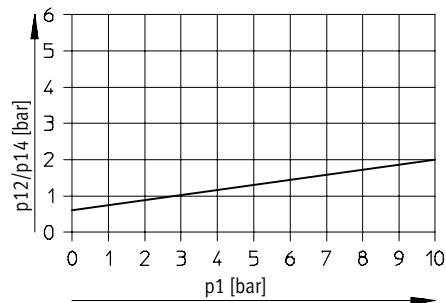

Valve response times [ms]

Pneumatic connection	G1/8		G1/4		G1/2
		Dominating signal at 14		Dominating signal at 14	
Internal pilot air supply					
On/changeover	–	16	–	24	–
Off/changeover	18	24	11	32	16
External pilot air supply					
On/changeover	–	–	–	–	–
Off/changeover	18	–	11	–	28

Double solenoid valves JMFH, Tiger Classic



Technical data – 5/2-way double solenoid valves

Electrical data			
F solenoid coil			
Electrical connection	Plug vanes for plug sockets MSSD-F, KMF		
Operating voltage	D.C. voltage	[V DC]	12, 24, 42, 48
	A.C. voltage	[V AC]	24, 42, 48, 110, 230, 240 (50 ... 60 Hz)
Coil characteristics	D.C. voltage	[W]	4.5
	A.C. voltage	[VA]	Pull: 7.5 Hold: 6
Protection class to EN 60 529	IP65 (in combination with plug socket)		

Materials

Sectional view

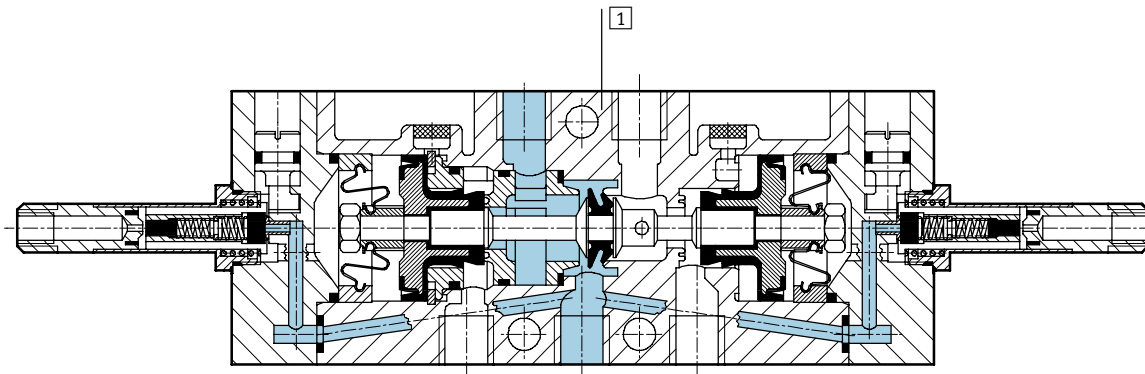

1	Housing	Aluminium die-cast, anodised
-	Seals	Nitrile rubber

Double solenoid valves JMFH, Tiger Classic

FESTO

Technical data – 5/2-way double solenoid valves

Dimensions

Download CAD data → www.festo.com/en/engineering

JMFH, JMFHDH

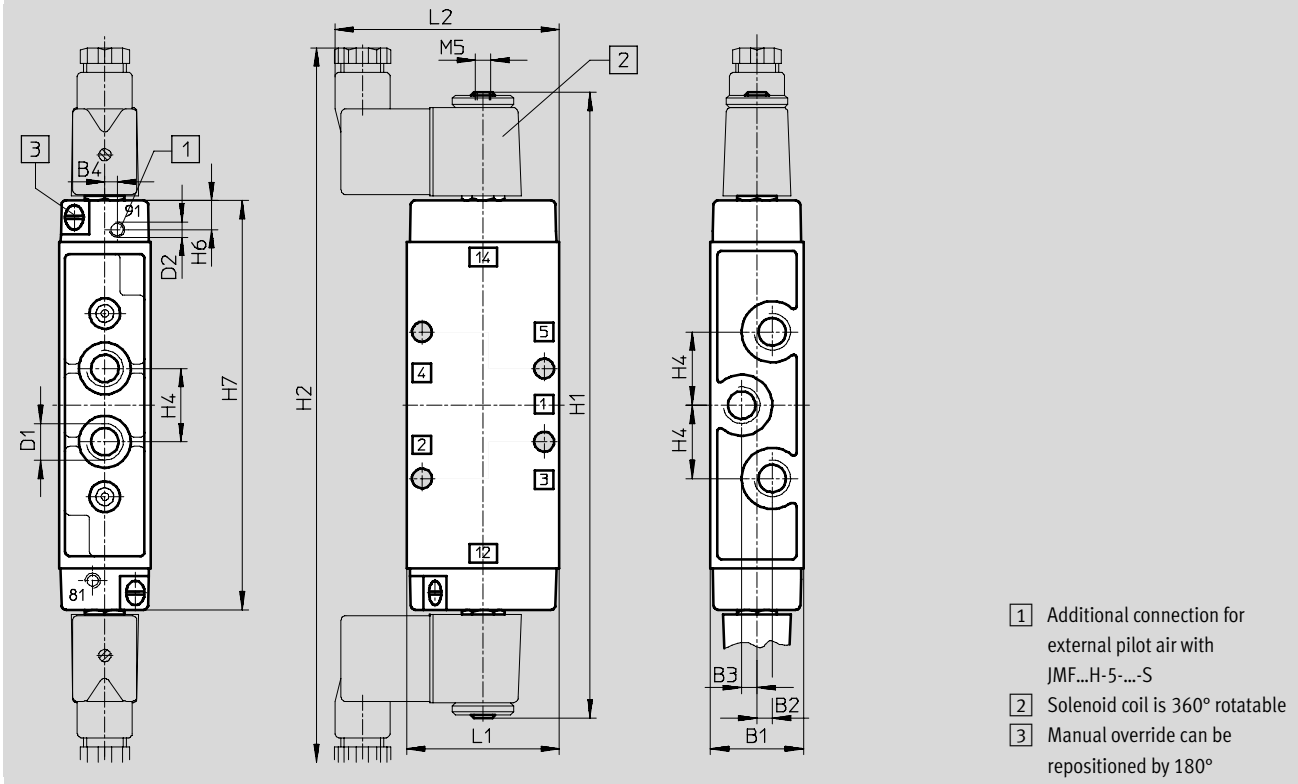

Pneumatic connection	B1	B2	B3	B4	D1	D2	H1	H2	H4	H6	H7	L1	L2
G $\frac{1}{8}$	26	3.5	3.5	2.7	G $\frac{1}{8}$	M5	184	217	19	9.5	116.5	45	71
G $\frac{1}{4}$	30.4	-	5	4	G $\frac{1}{4}$	M5	202	235	24	9.5	134	50	74
G $\frac{1}{2}$	52	-	8	-	G $\frac{1}{2}$	G $\frac{1}{8}$	244	272	38	10.5	176	80	89

Attachment diagram

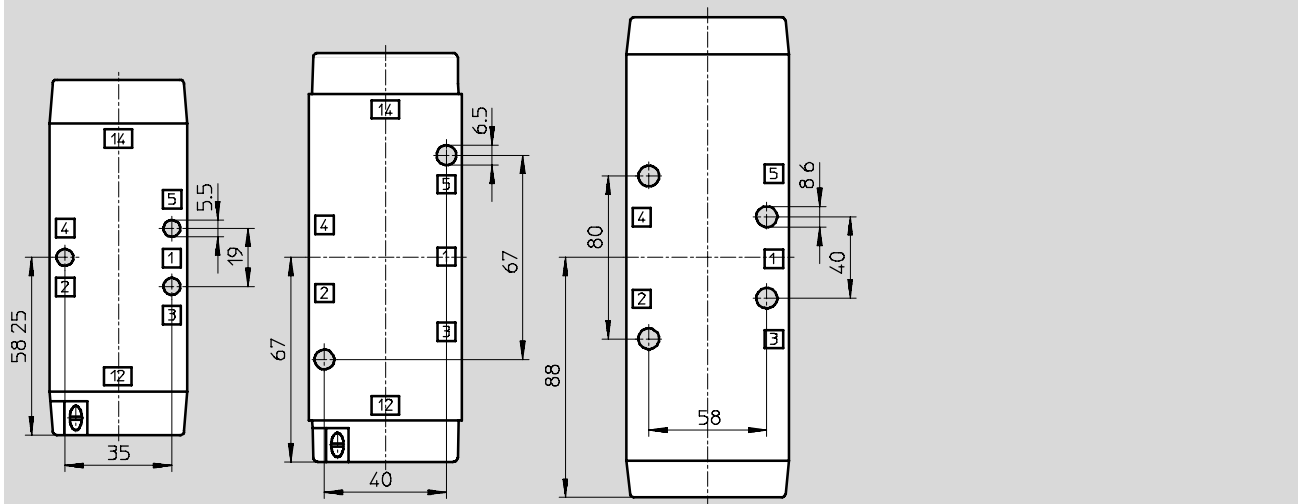

Directional control valves for standard applications
Tiger Classic

2.3

Double solenoid valves JMFH, Tiger Classic



Technical data – 5/2-way double solenoid valves

Directional control valves for standard applications
Tiger Classic

2.3

Ordering data				
Circuit symbol	Description	Pneumatic connection	Part No.	Type
	Without F solenoid coil ¹⁾ , internal pilot air supply	G ¹ / ₈	8 820	JMFH-5-1/8
		G ¹ / ₄	10 410	JMFH-5-1/4
		G ¹ / ₂	10 166	JMFH-5-1/2
	Without F solenoid coil ¹⁾ , external pilot air supply	G ¹ / ₈	14 008	JMFH-5-1/8-S
		G ¹ / ₄	14 009	JMFH-5-1/4-S
		G ¹ / ₂	35 548	JMFH-5-1/2-S
	Without F solenoid coil ¹⁾ , internal pilot air supply, with dominating signal at 14	G ¹ / ₈	8 821	JMFDH-5-1/8
		G ¹ / ₄	10 411	JMFDH-5-1/4

1) F solenoid coils → 2 / 2.3-44

Ordering data – Wearing parts kits		
Pneumatic connection	Part No.	Type
G ¹ / ₈	104 891	JMFH-5-1/8¹⁾
G ¹ / ₄	104 892	JMFH-5-1/4²⁾

- 1) Order mounting sleeves 228 389 separately
- 2) Order mounting sleeves 229 363 separately

Core Range

30.Pneumatic valves, Tiger Classic

Type codes

FESTO

		VL/O	-	3	-	1/4	-	
Type								
VL/O	Single pilot, normally open or closed							
VL	Single pilot							
JH	Double pilot							
JMFDH	Double pilot, dominant							
Valve function								
3	3/2-way valve							
5	5/2-way valve							
Pneumatic connection								
1/8	G1/8							
1/4	G1/4							
1/2	G1/2							
3/4	G3/4							
Generation								
B	Series B							

Pneumatic valves, Tiger Classic

Peripherals overview

FESTO

Directional control valves for standard applications
Tiger Classic

2.3

Mounting on manifold block

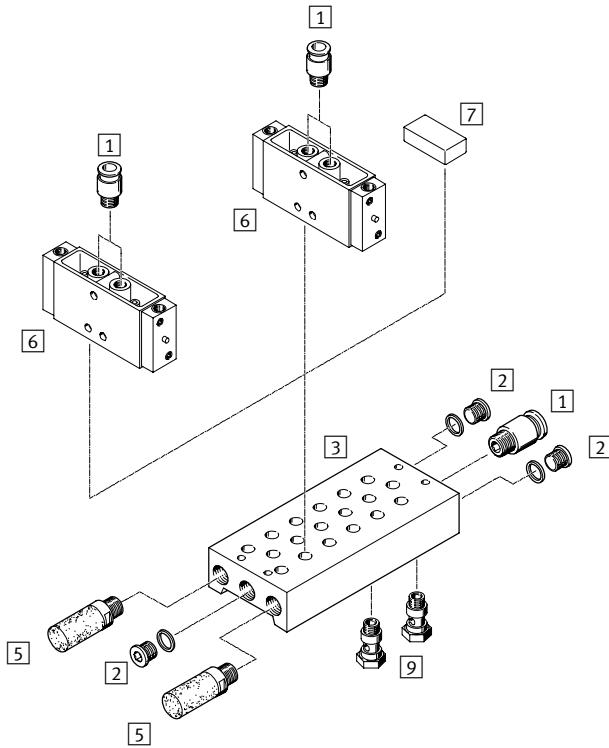

Mounting on manifold strip

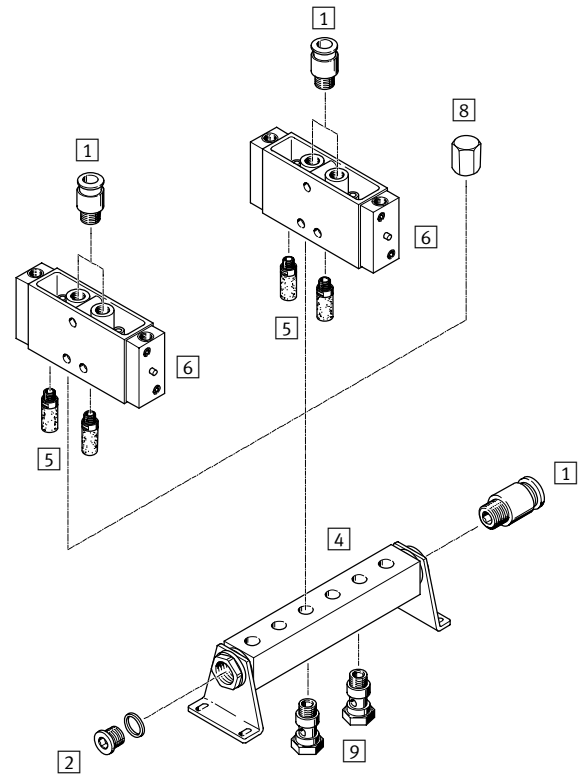

Accessories		
	Brief description	→ Page
1	Push-in fitting QS	For connecting standard O.D. tubing Volume 3 www.festo.com
2	Blanking plug G	3 included in the scope of delivery for PRS manifold block 1 included in the scope of delivery for PAL manifold strip Volume 3
3	Manifold block PRS	2 / 2.3-42
4	Manifold strip PAL	2 / 2.3-40
5	Silencer	For fitting in exhaust ports Volume 3 www.festo.com
6	Pneumatic valve VL, JH	
7	Blanking plate PRSB	For covering an unused valve position 2 / 2.3-43
8	Blanking cap VTM	For blanking an unused valve position 2 / 2.3-41
9	Hollow bolt VT	For distribution of compressed air or for separate compressed air supply 2 / 2.3-41

Pneumatic valves VL/O, Tiger Classic

FESTO

Technical data – 3/2-way valves

-  - Flow rate
500 ... 7,500 l/min

Wearing parts kits
→ 2 / 2.3-32



General technical data				
Pneumatic connection	G1/8	G1/4	G1/2	G3/4
Valve function	3/2-way, single pilot			
Constructional design	Poppet valve			
Sealing principle	Soft			
Actuation type	Pneumatic			
Type of reset	Mechanical spring			
Type of pilot control	Direct			
Direction of flow	Reversible			
Exhaust function	With flow control			
Manual override	None			
Type of mounting	Via through holes			
Mounting position	Any			
Nominal size [mm]	5	7	14	19
Standard nominal flow rate	500	800	3,700	7,500
Product weight [g]	150	230	860	1,200

Operating and environmental conditions				
Pneumatic connection	G1/8	G1/4	G1/2	G3/4
Operating medium	Filtered compressed air, lubricated or unlubricated Vacuum			
Operating pressure	Normally closed [bar]	-0.95 ... +10	-0.95 ... +10	-0.95 ... +10
	Normally open [bar]	0 ... 10	0 ... 10	0 ... 10
Pilot pressure	See diagram (max. 10 bar)			
Ambient temperature [°C]	-10 ... +60			

Directional control valves for standard applications
Tiger Classic

2.3

Pneumatic valves VL/O, Tiger Classic

Technical data – 3/2-way valves

FESTO

Minimal pilot pressure p_{12}/p_{14} as a function of operating pressure p_1

VL/O-3-1/8-B

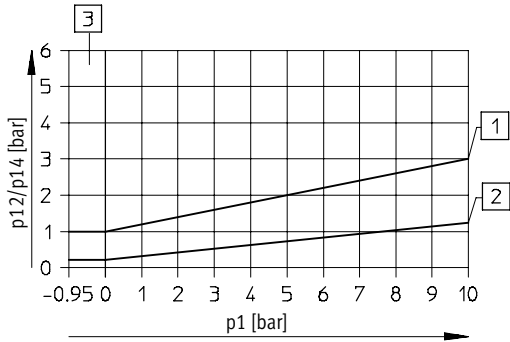

- 1 Switch-on pressure
- 2 Switch-off pressure
- 3 Only for normally closed

VL/O-3-1/4 – Normally closed

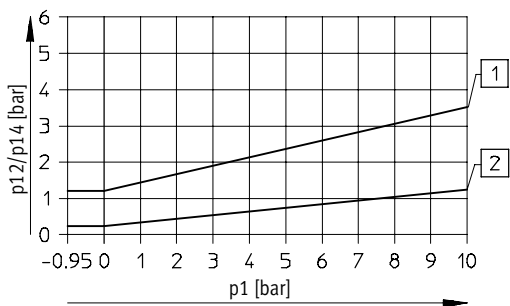

- 1 Switch-on pressure
- 2 Switch-off pressure

VL/O-3-1/4 – Normally open

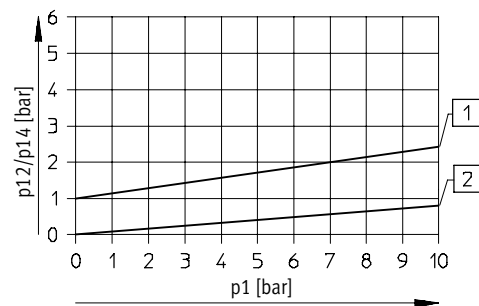

- 1 Switch-on pressure
- 2 Switch-off pressure

VL/O-3-1/2 – Normally closed

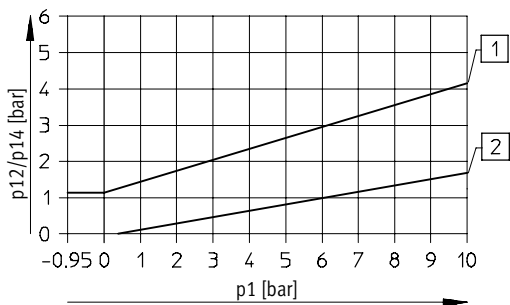

- 1 Switch-on pressure
- 2 Switch-off pressure

VL/O-3-1/2 – Normally open

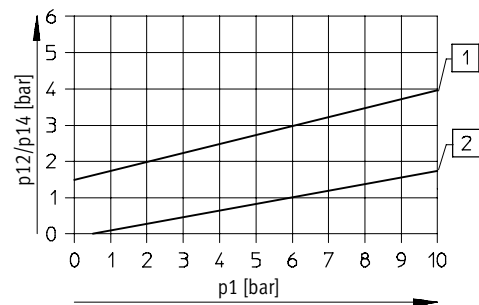

- 1 Switch-on pressure
- 2 Switch-off pressure

Pneumatic valves VL/O, Tiger Classic

Technical data – 3/2-way valves

FESTO

VL/O-3-3/4 – Normally closed

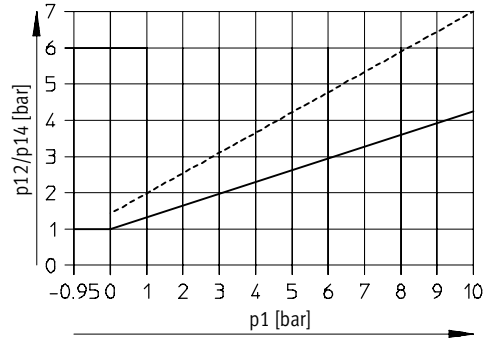

----- Exhaust throttled
 ——— Exhaust unthrottled

VL/O-3-3/4 – Normally open

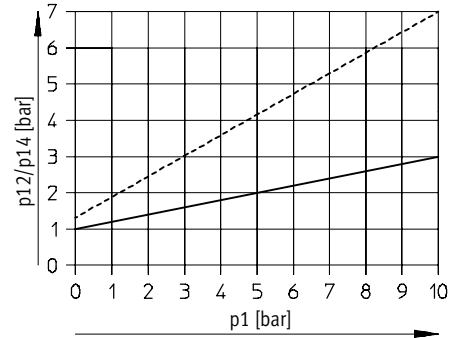

----- Exhaust throttled
 ——— Exhaust unthrottled

Valve response times [ms]

Pneumatic connection	G1/8	G1/4	G1/2	G3/4
On	4	8	17	23
Off	10	30	30	23

Materials

Sectional view

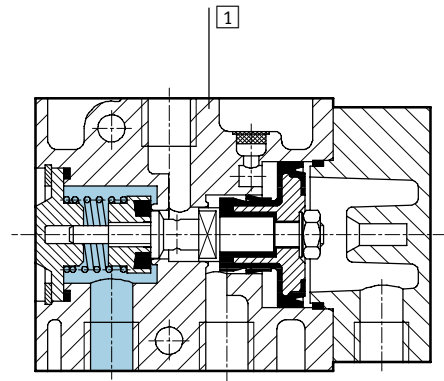

1	Housing	Aluminium die-cast, anodised
-	Seals	Nitrile rubber

Pneumatic valves VL/O, Tiger Classic

Technical data – 3/2-way valves

FESTO

Directional control valves for standard applications
Tiger Classic

2.3

Dimensions

Download CAD data → www.festo.com/en/engineering

VL/O

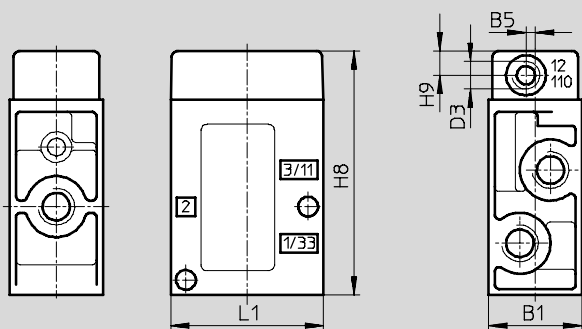

Pneumatic connection	B1	B5	D3	H8	H9	L1
G $\frac{1}{8}$	26	3	G $\frac{1}{8}$	65	8	45
G $\frac{1}{4}$	30.4	-	G $\frac{1}{8}$	80	8	50
G $\frac{1}{2}$	52	-	G $\frac{1}{4}$	118	10	80
G $\frac{3}{4}$	68	-	G $\frac{1}{4}$	138	10	92

Attachment diagram

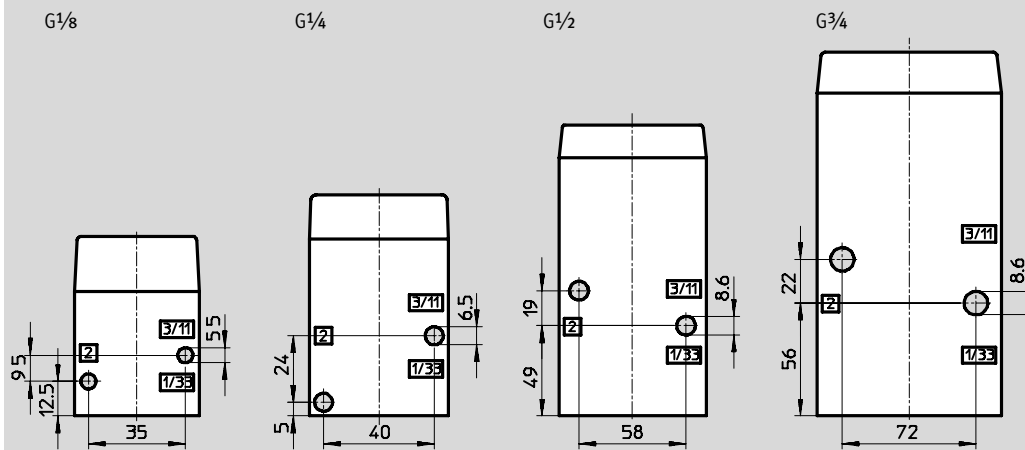

Ordering data

Circuit symbol	Description	Pneumatic connection	Part No.	Type
	Mechanical reset, optionally normally open or closed	G $\frac{1}{8}$	7 803	VL/O-3-1/8-B
		G $\frac{1}{4}$	9 984	VL/O-3-1/4
		G $\frac{1}{2}$	9 983	VL/O-3-1/2
		G $\frac{3}{4}$	10 049	VL/O-3-3/4

Ordering data – Wearing parts kits

Pneumatic connection	Part No.	Type
G $\frac{1}{8}$	104 222	VL/O-3-1/8-B
G $\frac{1}{4}$	104 207	VL/O-3-1/4
G $\frac{1}{2}$	104 208	VL/O-3-1/2

Pneumatic valves VL, Tiger Classic

FESTO

Technical data – 5/2-way valves

-  - Flow rate
500 ... 3,700 l/min

Wearing parts kits
→ 2 / 2.3-35



General technical data				
Pneumatic connection	G1/8	G1/4	G1/2	
Valve function	5/2-way, single pilot			
Constructional design	Poppet valve			
Sealing principle	Soft			
Actuation type	Pneumatic			
Type of reset	Mechanical spring			
Type of pilot control	Direct			
Direction of flow	Non reversible			
Manual override	None			
Exhaust function	With flow control			
Type of mounting	Via through holes			
Mounting position	Any			
Nominal size	[mm]	5	7	14
Standard nominal flow rate	[l/min]	500	800	3,700
Product weight		180	220	1,070

Operating and environmental conditions				
Pneumatic connection	G1/8	G1/4	G1/2	
Operating medium	Filtered compressed air, lubricated or unlubricated			
Operating pressure	[bar]	0 ... 10	0 ... 8	0 ... 10
Pilot pressure	[bar]	See diagram (max. 10 bar)		
Ambient temperature	[°C]	-10 ... +60		

Directional control valves for standard applications
Tiger Classic

2.3

Pneumatic valves VL, Tiger Classic

Technical data – 5/2-way valves



Minimal pilot pressure p_{12}/p_{14} as a function of operating pressure p_1

VL-5-3/8

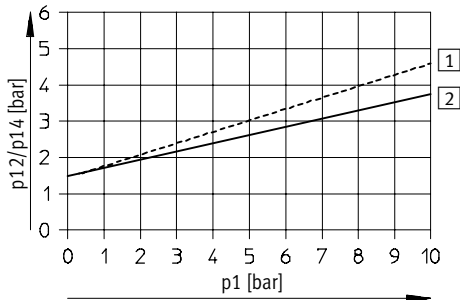

----- Exhaust throttled
 _____ Exhaust unthrottled

VL-5-1/4

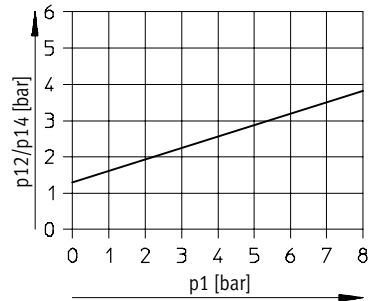

VL-3-1/2

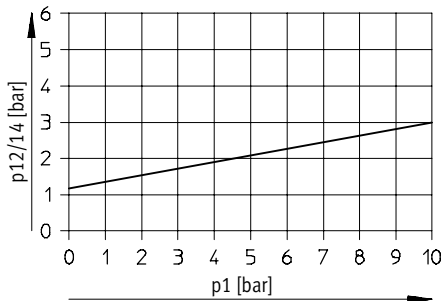

Valve response times [ms]

Pneumatic connection	G1/8	G1/4	G1/2
On	5	8	6
Off	16	12	27

Materials

Sectional view

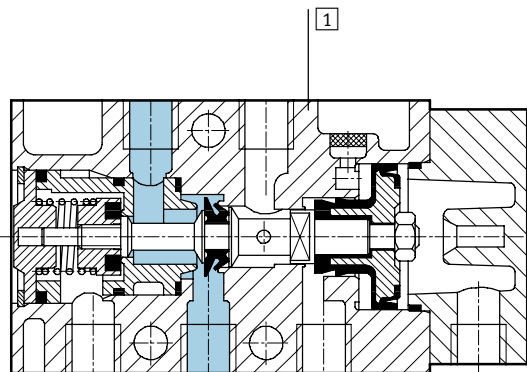

1	Housing	Aluminium die-cast, anodised
-	Seals	Nitrile rubber

Pneumatic valves VL, Tiger Classic

Technical data – 5/2-way valves

FESTO

Dimensions

Download CAD data → www.festo.com/en/engineering

VL

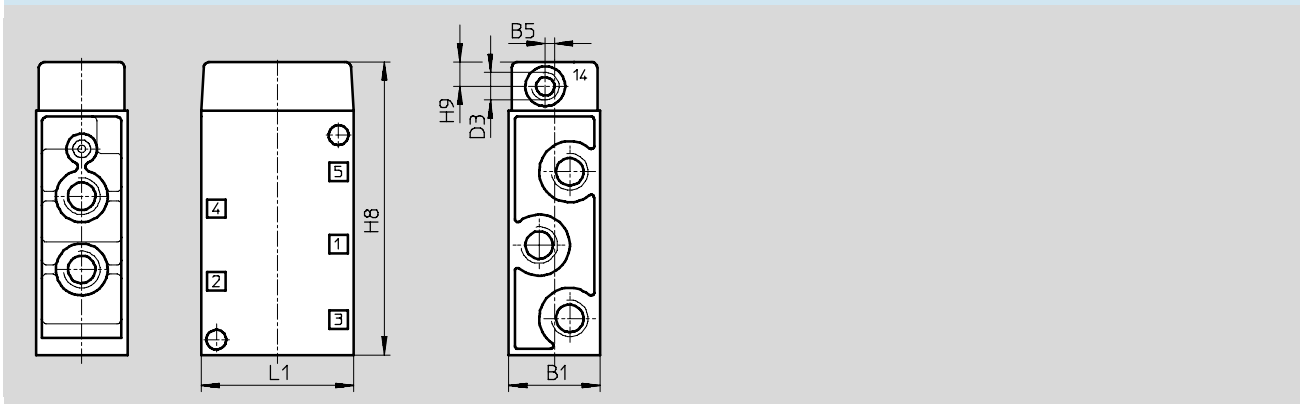

Pneumatic connection	B1	B5	D3	H8	H9	L1
G1/8	26	3	G1/8	85	8	45
G1/4	30.4	-	G1/8	96	8	50
G1/2	52	-	G1/4	159	10	80

Attachment diagram

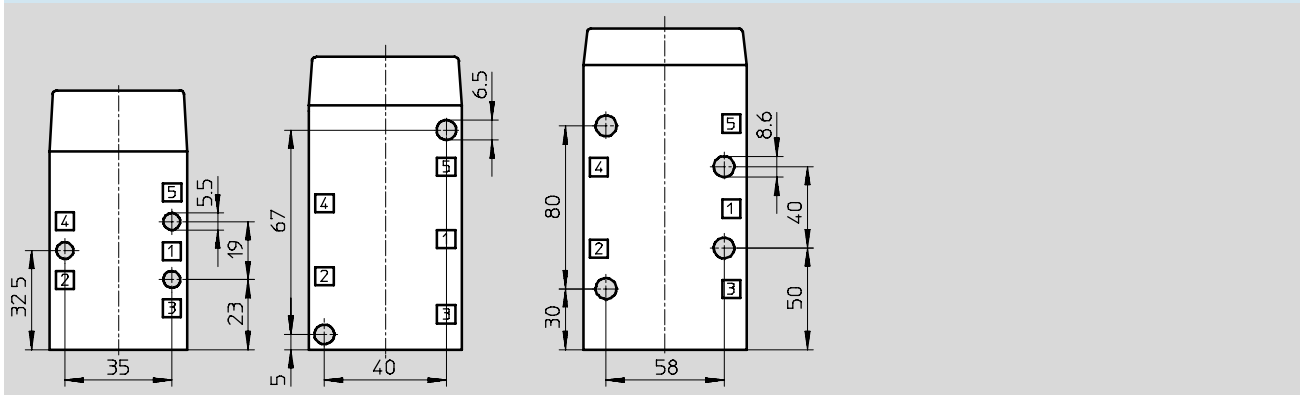

Ordering data

Circuit symbol	Description	Pneumatic connection	Part No.	Type
	Mechanical reset	G1/8	9 764	VL-5-1/8
		G1/4	9 199	VL-5-1/4
		G1/2	9 445	VL-5-1/2

Ordering data – Wearing parts kits

Pneumatic connection	Part No.	Type
G1/8	104 209	VL-5-1/8 ¹⁾
G1/4	104 211	VL-5-1/4 ²⁾³⁾
G1/2	104 212	VL-5-1/2

- 1) Order mounting sleeves 228 389 separately
- 2) Order mounting sleeves 229 363 separately
- 3) Use from 1/81 series

Directional control valves for standard applications
Tiger Classic

2.3

Pneumatic valves JH, Tiger Classic

Technical data – 5/2-way valves, double pilot valves

FESTO

-  - Flow rate
600 ... 4,500 l/min

Wearing parts kits
→ 2 / 2.3-39



General technical data				
Pneumatic connection	G1/8	G1/4	G1/2	
Valve function	5/2-way, double pilot			
Constructional design	Poppet valve			
Sealing principle	Soft			
Actuation type	Pneumatic			
Type of pilot control	Direct			
Direction of flow	Non reversible			
Exhaust function	With flow control			
Manual override	Resetting			
Type of mounting	Via through holes			
Mounting position	Any			
Nominal size	[mm]	5	7	14
Standard nominal flow rate		600	1,100	4,500
Product weight	[g]	245	330	1,130

Operating and environmental conditions				
Pneumatic connection	G1/8	G1/4	G1/2	
Operating medium	Filtered compressed air, lubricated or unlubricated			
Operating pressure	[bar]	0 ... 10	0 ... 8	0 ... 10
Pilot pressure	[bar]	See diagram (max. 10 bar)		
Ambient temperature	[°C]	-10 ... +60		

Pneumatic valves JH, Tiger Classic

Technical data – 5/2-way valves, double pilot valves

Minimal pilot pressure p_{12}/p_{14} as a function of operating pressure p_1

JH-5-1/8

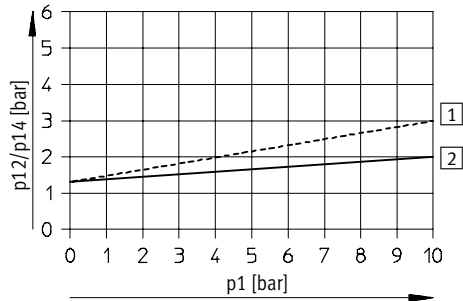

----- Exhaust throttled
 ————— Exhaust unthrottled

JDH-5-1/8

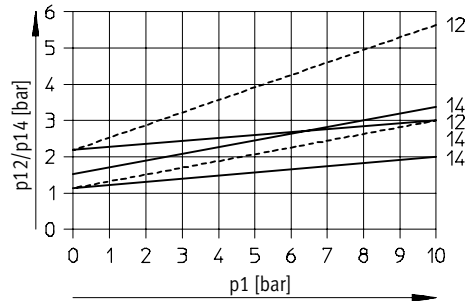

----- Exhaust throttled
 ————— Exhaust unthrottled

JH-5-1/4

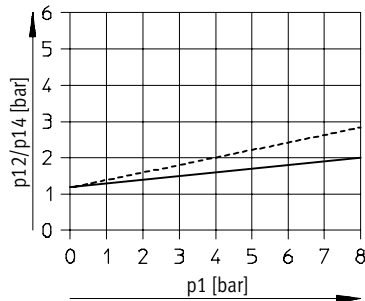

----- Exhaust throttled
 ————— Exhaust unthrottled

JDH-5-1/4

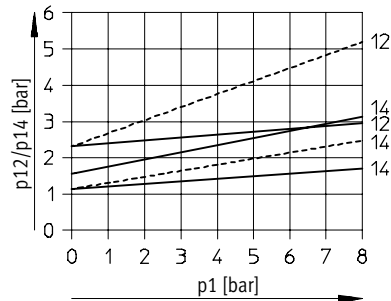

----- Exhaust throttled
 ————— Exhaust unthrottled

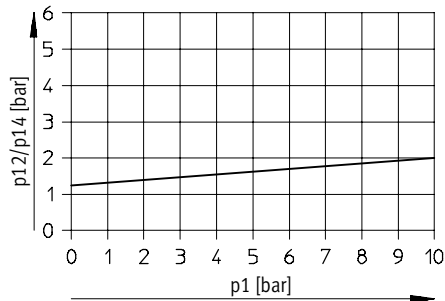

Valve response times [ms]					
Pneumatic connection	G1/8		G1/4		G1/2
	Dominating signal at 14		Dominating signal at 14		
On/changeover	–	9	–	7	–
Off/changeover	2	16	7	16	3

Pneumatic valves JH, Tiger Classic

Technical data – 5/2-way valves, double pilot valves



Materials

Sectional view

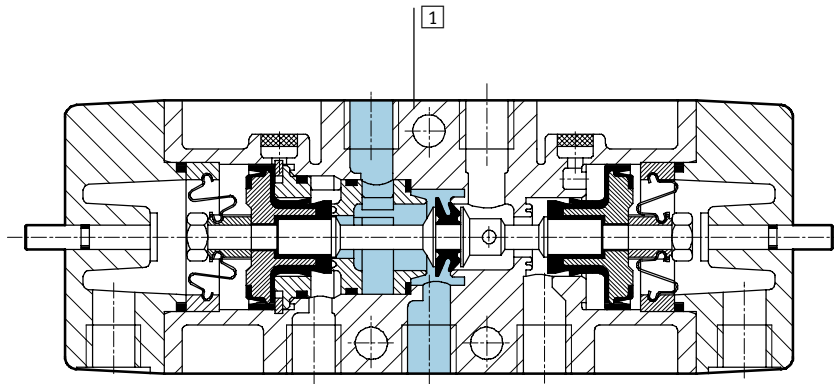

1	Housing	Aluminium die-cast, anodised
-	Seals	Nitrile rubber

Dimensions

Download CAD data → www.festo.com/en/engineering

JH, JDH

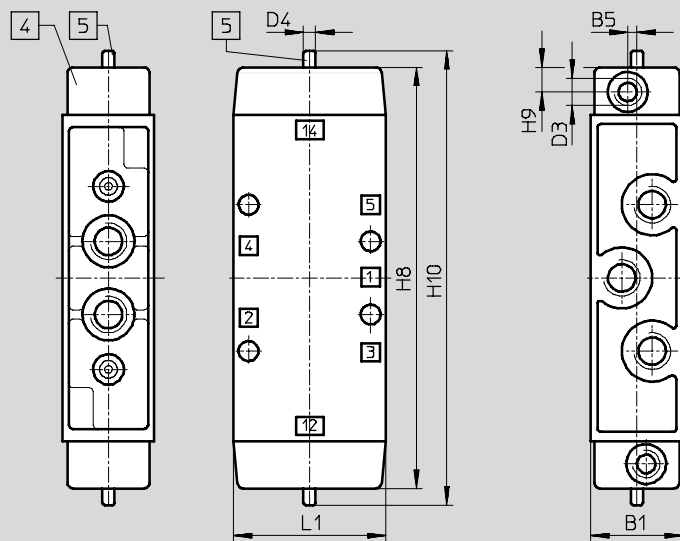

- 4 Cover can be repositioned by 180°
- 5 Manual override

Pneumatic connection	B1	B5	D3	D4 Ø	H8	H9	H10	L1
G ¹ / ₈	26	3	G ¹ / ₈	5	120	8	132	45
G ¹ / ₄	30.4	-	G ¹ / ₈	5	138	8	149	50
G ¹ / ₂	52	-	G ¹ / ₄	9.9	178	10	193	80

Pneumatic valves JH, Tiger Classic

Technical data – 5/2-way valves, double pilot valves

Attachment diagram

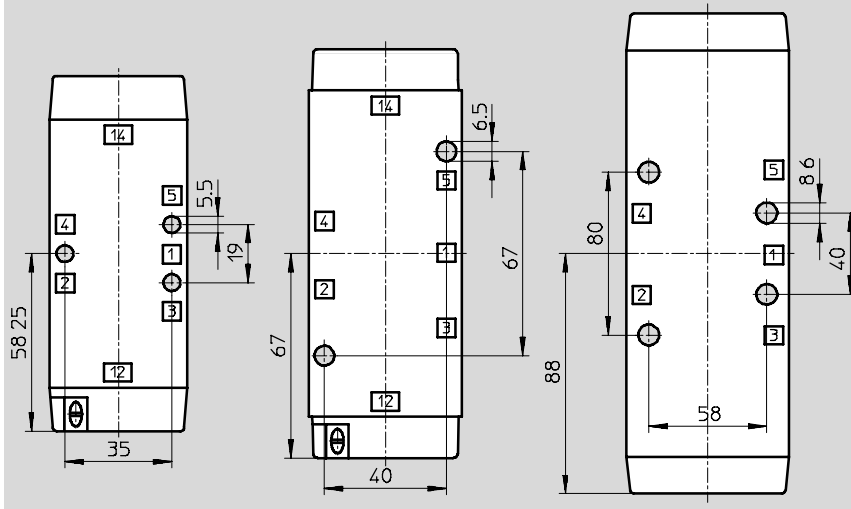

Ordering data

Circuit symbol	Description	Pneumatic connection	Part No.	Type
		G1/8	8 823	JH-5-1/8
		G1/4	10 408	JH-5-1/4
		G1/2	10 165	JH-5-1/2
	With dominating signal at 14	G1/8	8 824	JDH-5-1/8
		G1/4	10 409	JDH-5-1/4

Ordering data – Wearing parts kits

Pneumatic connection	Part No.	Type
G1/8	104 891	JH-5-1/8 ¹⁾
G1/4	104 892	JH-5-1/4 ²⁾

- 1) Order mounting sleeves 228 389 separately
- 2) Order mounting sleeves 229 363 separately

Core Range

Solenoid/pneumatic valves, Tiger Classic



Accessories

Manifold strip

PAL

Materials:

Manifold: anodised aluminium

Mounting bracket: galvanised steel

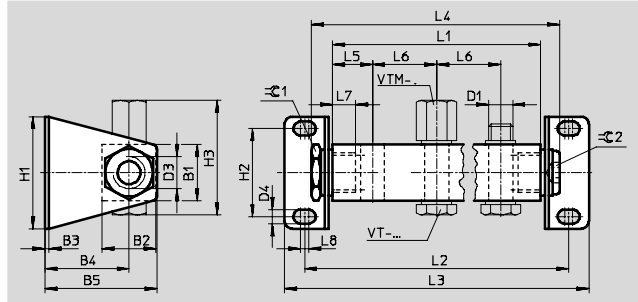
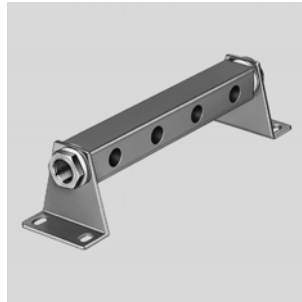

Dimensions and ordering data																		
Type	B1	B2	B3	B4	B5	D1	D3	D4	H1	H2	H3	L5	L6	L7	L8	∅C1	∅C2	
PAL-1/8-...	20	21	2	33.5	44.5	G1/8	G1/4	5.2	44	32	43	18	34	12	4	19	8	
PAL-1/4-...	28	27	2	42	56	G1/4	G3/8	7	56	44	56	20	32	14	4	24	10	
PAL-1/2-...	40	40	3	73	93	G1/2	G3/4	11	80	60	75	35	69	16	5	36	17	

Number of valve ports	L1	L2	L3	L4	Weight [g]	Part No.	Type
Pneumatic connection G1/8							
2	70	96	114	89	145	8 601	PAL-1/8-2
3	104	130	148	123	170	8 602	PAL-1/8-3
4	138	164	182	157	190	8 603	PAL-1/8-4
5	172	198	216	191	215	8 604	PAL-1/8-5
6	206	232	250	225	240	9 767	PAL-1/8-6
Pneumatic connection G1/4 ¹⁾							
2	72	100	120	94	330	9 188	PAL-5-1/4-2
3	104	132	152	126	405	9 189	PAL-5-1/4-3
4	136	164	184	158	480	9 190	PAL-5-1/4-4
5	168	196	216	190	555	9 191	PAL-5-1/4-5
6	200	228	248	222	630	9 192	PAL-5-1/4-6
Pneumatic connection G1/2							
2	139	181	213	164	770	9 492	PAL-1/2-2
3	208	250	282	233	915	9 493	PAL-1/2-3
4	277	319	351	302	1 060	9 494	PAL-1/2-4
5	346	388	420	371	1 220	9 495	PAL-1/2-5
6	415	457	489	440	1 370	9 496	PAL-1/2-6

1) MOFH-3-1/4 is not suitable for manifold mounting

Solenoid/pneumatic valves, Tiger Classic

Accessories

Hollow bolt

VT

For manifold strip PAL

Material:

galvanised steel



Ordering data			
Pneumatic connection	Weight [g]	Part No.	Type
G ¹ / ₈	6	8 626	VT-1/8
G ¹ / ₄	15	5 928	VT-1/8-1 ¹⁾
G ¹ / ₄	15	206 147	VT-1/4-2
G ¹ / ₂	30	9 986	VT-1/2

1) For valves with G¹/₈ connection

Blanking cap

VTM

For sealing vacant valve positions

Material:

wrought aluminium alloy

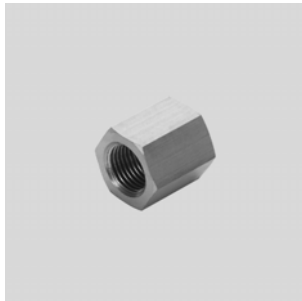

Ordering data			
Pneumatic connection	Weight [g]	Part No.	Type
G ¹ / ₈	5	9 768	VTM-1/8
G ¹ / ₄	5	9 768	VTM-1/8 ¹⁾
G ¹ / ₄	7	3 099	VTM-1/4
G ¹ / ₂	28	9 987	VTM-1/2

1) For valves with G¹/₈ connection

Solenoid/pneumatic valves, Tiger Classic



Accessories

Manifold block PRS

Material:
anodised aluminium

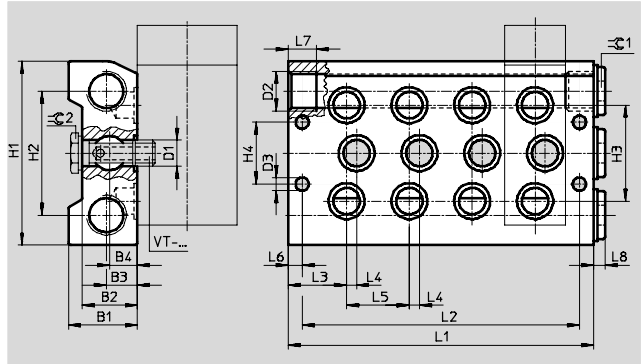

Dimensions and ordering data

Type	B1	B2	B3	B4	D1	D2	D3	H1	H2	H3	H4	L3	L4	L5	L6	L7	L8	∅ 1	∅ 2
PRS-1/8-...	28.5	22	12.5	10.8	G1/8	G3/8	6.6	80	56	38	28	23.5	7	27	7	12	5	8	14
PRS-1/4-...	34.5	27.5	14	14	G1/4	G1/2	6.6	92	62	48	31	29.2	5	31.4	7	14	6	10	17

Number of valve ports	L1	L2	Weight [g]	Part No.	Type
Pneumatic connection G1/8					
2	81	67	360	11 898	PRS-1/8-2
3	108	94	460	11 899	PRS-1/8-3
4	135	121	625	11 900	PRS-1/8-4
5	162	148	650	11 901	PRS-1/8-5
6	189	175	750	11 902	PRS-1/8-6
Pneumatic connection G1/4					
2	89.8	75.8	590	10 185	PRS-1/4-2
3	121.2	107.2	750	10 186	PRS-1/4-3
4	152.6	138.6	900	10 187	PRS-1/4-4
5	184	170	1070	10 188	PRS-1/4-5
6	215.4	201.4	1 230	10 189	PRS-1/4-6

Hollow bolt VT

For manifold block PRS

Material:
galvanised steel



Ordering data			
Pneumatic connection	Weight [g]	Part No.	Type
G1/8	17	11 539	VT-1/8-PRSK
G1/4	32	9 499	VT-1/4-PRS

Solenoid/pneumatic valves, Tiger Classic

Accessories

Blanking plate

PRSB

For sealing vacant valve positions

Material:
aluminium



Ordering data			
Pneumatic connection	Weight [g]	Part No.	Type
G ¹ / ₈	55	11 687	PRSB-1/8
G ¹ / ₄	80	11 688	PRSB-1/4

Hollow bolt

VT

For separate compressed air supply on valve

Material:
galvanised steel



Ordering data			
Pneumatic connection	Weight [g]	Part No.	Type
G ¹ / ₈	16	12 634	VT-1/8-AJK-P
G ¹ / ₄	24	12 910	VT-1/8-AJS-P*
G ¹ / ₄	45	12 635	VT-1/4-AJ-P

1) For valves with G¹/₈ connection





Solenoid/pneumatic valves, Tiger Classic

Accessories

FESTO

Directional control valves for standard applications
Tiger Classic

2.3

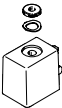
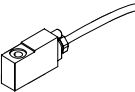

Ordering data		
	Note	Part No. Type
Push-in/threaded fittings QS		
		→ Volume 3 → www.festo.com
Silencer		
		→ Volume 3 → www.festo.com
Blanking plug		
	A blanking plug is included in the scope of delivery for manifold strip PAL. 3 blanking plugs are included in the scope of delivery for manifold block PRS.	→ Volume 3 → www.festo.com
Reducing nipple		
	A reducing nipple is included in the scope of delivery for manifold strip PAL. 3 reducing nipples are included in the scope of delivery for manifold block PRS.	→ Volume 3 → www.festo.com

Ordering data – Solenoid coils			Data sheets → NO TAG	
Ordering data – Solenoid coils			Data sheets → www.festo.com	
	Voltage	Cable length [m]	Part No.	Type
F solenoid coils				
	12 V DC	–	34 410	MSFG-12DC-OD
	24 V DC and 42 V AC, 50 ... 60 Hz	–	34 411	MSFG-24DC/42AC-OD
	42 V DC	–	34 413	MSFG-42DC-OD
	24 V AC	–	34 415	MSFG-24AC-OD
	48 V AC, 50 ... 60 Hz	–	34 418	MSFW-48AC-OD
	110 V AC, 50 ... 60 Hz and 120 V AC, 60 Hz	–	34 420	MSFW-110AC-OD
	230 V AC, 50 ... 60 Hz and 240 V AC, 60 Hz	–	34 422	MSFW-230AC-OD
	240 V AC, 50 ... 60 Hz	–	34 424	MSFW-240AC-OD
F solenoid coils – Explosion-proof to EN 50 028				
	24 V DC	1	535 619	MSFG-24DC-EX
	24 V DC	5	535 621	MSFG-24DC-EX-K5
	24 V AC, 50 ... 60 Hz	1	535 623	MSFW-24AC-EX
	110 V AC, 50 ... 60 Hz	1	535 622	MSFW-110AC-EX
	230 V AC, 50 ... 60 Hz	1	535 620	MSFW-110AC-EX
	230 V AC, 50 ... 60 Hz	5	535 625	MSFW-110AC-EX-K5

Solenoid/pneumatic valves, Tiger Classic

Accessories

FESTO

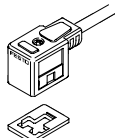
Ordering data – Plug sockets/plug sockets with cable for F solenoid coils					
	Voltage	Cable length [m]	LED	Part No.	Type
Plug socket without cable					Data sheets → NO TAG
Plug socket without cable					Data sheets → www.festo.com
	–	–	–	34 431	MSSD-F
	–	–	–	539 710	MSSD-F-M16
Plug socket without cable with insulation displacement technology					Data sheets → NO TAG
Plug socket without cable with insulation displacement technology					Data sheets → www.festo.com
	–	–	–	192 746	MSSD-F-S-M16
Plug socket with cable					Data sheets → NO TAG
Plug socket with cable					Data sheets → www.festo.com
	24 V DC	2.5	■	30 935	KMF-1-24DC-2,5-LED
	24 V DC	5	■	30 937	KMF-1-24DC-5-LED
	24 V DC	10	■	193 458	KMF-1-24DC-10-LED
	Up to 240 V	2.5	–	30 936	KMF-1-230AC-2,5
	Up to 240 V	5	–	30 938	KMF-1-230AC-5

Ordering data – Illuminating seal				Data sheets → NO TAG	
Ordering data – Illuminating seal				Data sheets → www.festo.com	
	Voltage	Part No.	Type		
For F solenoid coils					
	12 ... 24 V DC	19 143	MF-LD-12-24DC		
	230 V DC/V AC	19 144	MF-LD-230AC		

Directional control valves for standard applications
Tiger Classic

2.3