

VTSA Valve Terminal

The Highest Degree of Modularity

VTSA Valves on Single Subbase

- Size 01 (26 mm) and Size 02 (18 mm)
- Flow rate: up to 1.0 Cv (1000 l/min)
- Terminal strip or M12 connector
- NPT and G (BSPP) ported connections



VTSA Terminal with Multipin Connection

- Combine Size 01 with Size 02
- Sub-D, round connector, or terminal strip
- Max. 32 valve positions / 32 solenoid coils
- 24 V DC or 110 V AC solenoids

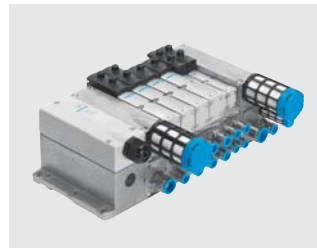

VTSA Terminal with Fieldbus Connection

- All major fieldbus protocols are available
- Max. 32 valve positions / 32 solenoid coils
- Handheld MMI – settings, configurations, and diagnostics
- Diagnosis down to the individual valve



The Highest Degree of Custom Integration



Integration

The VTSA valve terminal can be integrated into all current fieldbus systems and Ethernet links via a CPX terminal and can interface to numerous I/O modules. The VTSA valve terminal can also be used as a multipin or terminal box variant. The Festo plug and work® terminal is simple to install and service on site.



Flexible and Modular

The VTSA valve terminal offers the highest degree of flexibility and modularity in both the pneumatic and electric circuits. All components – I/O modules, manifold bases, and valves – can be easily exchanged or expanded to meet your most complex system requirements.



Fault Diagnostics

The VTSA valve terminal supports a full diagnostic concept. Perform point level diagnostics such as missing coil and shorted coil, and module level diagnostics such as no power to coil or module failure. Identify faults locally via LED functions or using a CPX-MMI handheld diagnostic unit. When using the CPX, relay diagnostic information through the fieldbus back to the master controller.



Standardization

The VTSA valve terminal conforms fully to the ISO 15407-2 standard regardless of electrical interface desired. Conformance to an international standard assures a global compatibility and acceptance of the valve terminal.



Festo...Your Automation Partner Worldwide

As a global leader in industrial automation components and systems, with over \$1.8 billion sales worldwide, Festo has the resources and application experience to be your long term partner for cost-effective automation solutions.

- 55 independent subsidiaries worldwide
- Representation in 180 countries
- Worldwide networking for consistent standards of products, consultancy, sales and services.
- Worldwide support provided by over 11,000 team members

Festo Quality Assurance, ISO 9001 Certification

Festo Corporation is committed to provide Festo products and services that will meet or exceed our customers' requirements in product quality, delivery, customer service and satisfaction.



All Festo locations within the United States are registered to ISO 9001.

Online Literature

Literature in PDF format is available for download at: www.festo.com/us/VTSA

Table of Contents

Features and Benefits	4
Online Product Configurator	6
Overview	
Key Features	8
Electrical Connections	9
Pneumatic Components	10
Electrical Components.....	11
Multi-pin Connection	12
Fieldbus Connection	14
Single Subbases	16
Pneumatic Components	
Valve Functions	18
Vertical Stacking	20
Manifold Subbases	25
Air Supply	26
Pressure Zones	31
Electrical Components	
Connections and Addressing	35
Pin Allocation – Sub-D Plug	36
Pin Allocation – Cage Clamp	38
Pin Allocation – Round Plugs.....	39
Pin Allocation – M12x1, 4-pin Plug	40
Installation and Operation	
Mounting.....	41
Pneumatic/Electrical Connection.....	42
Manual Override and Labeling.....	43
Technical Data	
Pneumatic	44
Electrical	49
Dimensions	50
Ordering Data	
ISO Thread Configuration	
– Multi-pin Connection	59
– CPX Fieldbus Connection	64
NPT Thread Configuration	
– Multi-pin Connection	69
– CPX Fieldbus Connection	74
Individual Valves	79
End Plates and Subbases	80
Plates and Regulator Blocks	81
Pneumatic/Electrical Components	82
Accessories	
Pneumatic Components	83
Mounting Components/Manuals.....	84
Operating Recommendations	85

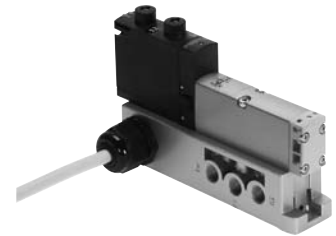

VTSA Valve on Single Subbase with M12 Connector

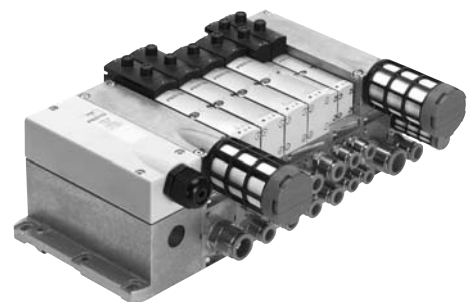

VTSA Valve Terminal with Multi-pin Connection

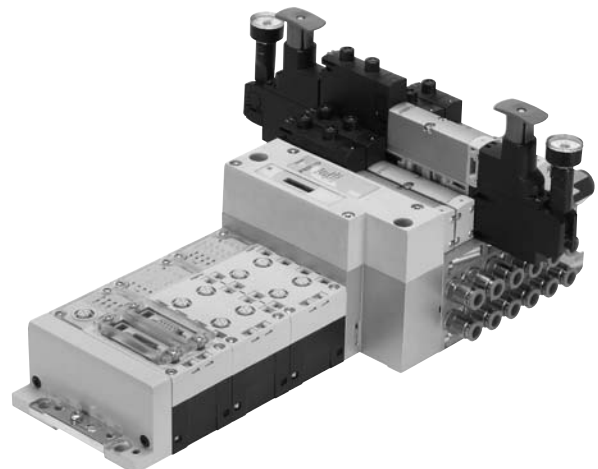

VTSA Valve Terminal with Fieldbus Connection

A Higher Degree of Modularity

- Valves in accordance with ISO 15407-2. The VTSA terminal can be used for all applications
- Simple connection of pneumatic and electrical components
- Flow rate up to 1.0 Cv (1000 l/min)
- 5/2-way, 2x 3/2-way and 5/3-way valve functions
- Voltage options: 24 V DC or 110 V AC
- IP65 rated
- Modular and flexible
- Easy diagnostics and maintenance
- Reliable and durable
- Competitive pricing

Flexible

- Easy modification and expansion due to high degree of modularity. Fast connection of the subbases by means of four screws.
- Fully modular system allows the combination of 18 mm (Size 02) and 26 mm (Size 01) valves on the same manifold without the need for any transition/adaptor plate.
- Change direction of working ports with easy-to-install angle plate.
- Fieldbus valve terminal suitable for CPX electrical peripherals. This means:
 - There is an advanced internal communication system for activation of the valves and CPX modules

Easily Integrated

- Fieldbus nodes: Interbus, DeviceNet™, Profibus DP, CANopen, CC-Link via CPX terminal
- Ethernet: Modbus/TCP, EtherNet/IP™, TCP/IP via CPX terminal
- Digital I/O modules: Up to 8 digital inputs plus 8 digital outputs
- Analog I/O modules: 2 analog inputs or 2 analog outputs
- Expandable up to 32 solenoid coils
- Conversions and extensions are possible at any time
- Integration of a wide range of function modules possible
- Supply plates permit a flexible air supply and variable pressure zones

Comprehensive

- High-performance valves in a sturdy metal housing
- Complete range of vertical sandwich components such as pressure regulators, flow control valve, individual pressure supply, shutoff plate (hot swap).
- Standard air qualities: 40 micron grade of filtration. Can be used with lubricated or non-lubricated air, and inert gases.
- Manual override available, with momentary, locking, or hidden (non-accessible) options.
- Reverse operation

Installation and Maintenance

- Ready-to-install unit, preassembled and tested
- Durable, low cost identification by label holder on the valve or label holder on the subbase.
- Secure wall mounting or DIN rail mounting
- Fast troubleshooting thanks to LEDs on the valves and diagnosis via fieldbus.
- Reliability of service thanks to valves that can be replaced easily and quickly.
- Easy fault identification using CPX-MMI handheld diagnostic unit.

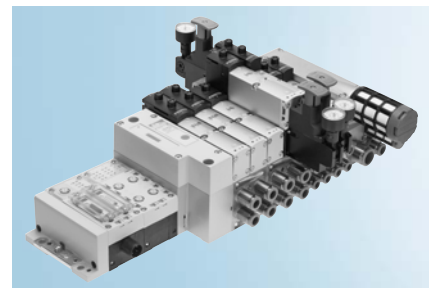
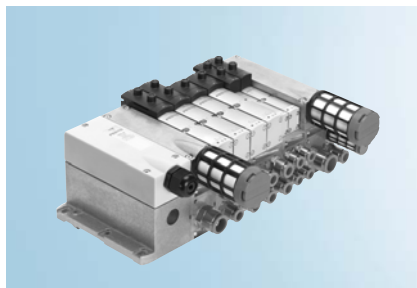
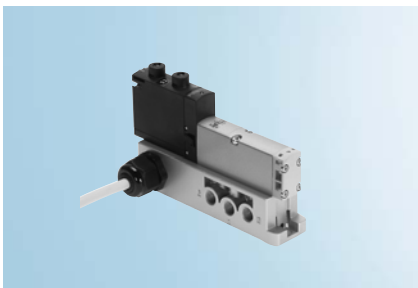

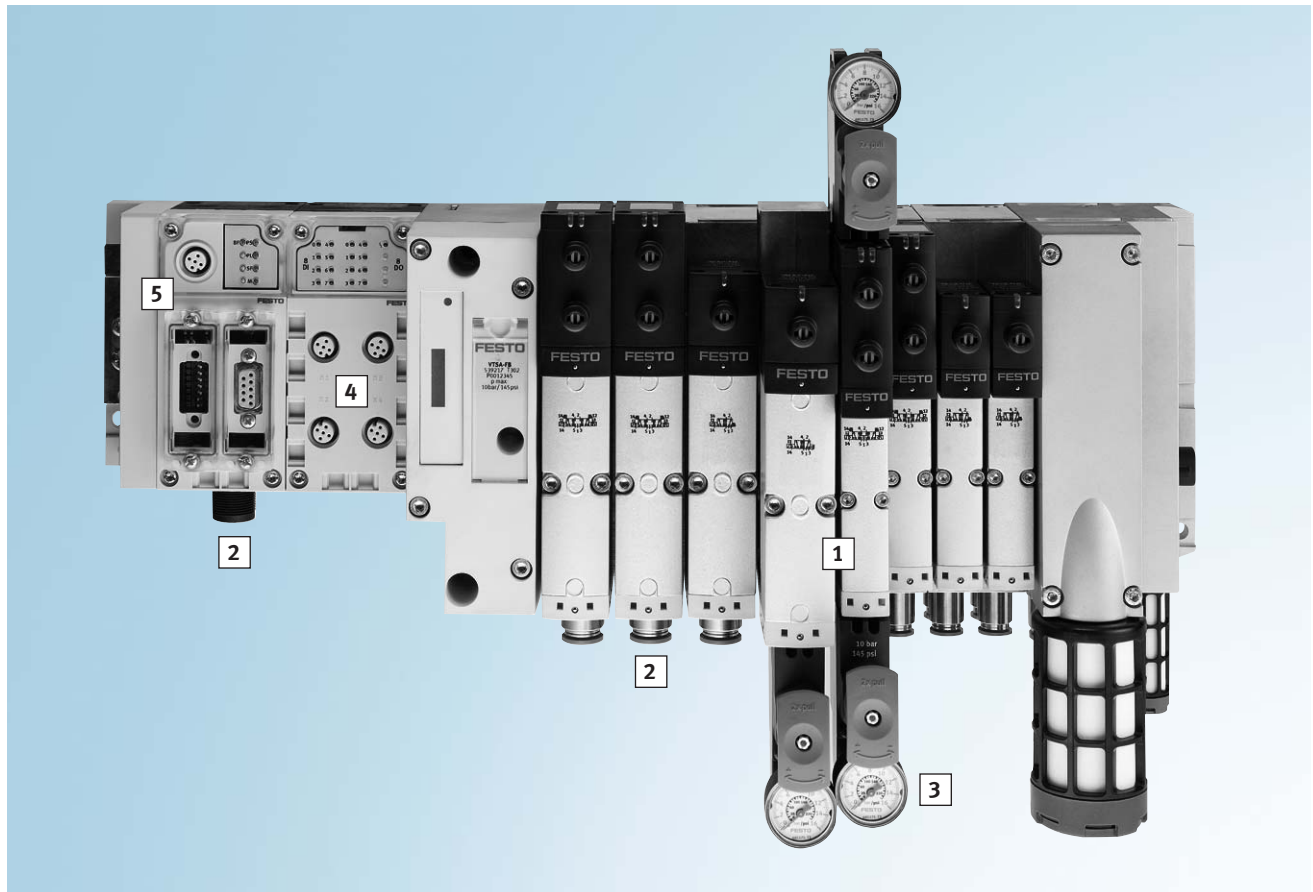

1 Combination of Sizes

The flexible combination of both valve sizes on a single valve terminal (18 mm and 26 mm) allows adaptation to different flow requirements. For greater freedom and optimized applications.

2 Standardized Connection Direction

There is only one direction for all connections, whether they are electrical or pneumatic. This saves space and provides greater clarity.

3 Operating Efficiency

Adjustment of regulators without tools. And with the standardized operating direction from above for regulators and valves, this terminal offers the solution to just about every requirement in terms of functionality.

4 Connection to CPX

What about fieldbus and modular I/Os? Connection to the modern CPX terminal is an added benefit. This level of freedom, modularity, and versatility is unmatched in standards-based products.

5 Decentralized Intelligence

The CPX-MMI-1 hand-held device explains errors in plain text and helps reduce downtimes. Remote maintenance via Ethernet/Internet eliminates the need for servicing at night and over long distances, which can often be very expensive. The on-site intelligence permits CMS (Condition Monitoring Systems) for each valve and statistical error logging with history and timestamp.

FACE Configurator

Electronic Catalog at www.festo.com/us

A valve terminal configurator is available to help you configure a suitable VTSA valve terminal.

The valve terminals are fully assembled according to your order specifications and individually tested. This reduces the amount of assembly and installation required to a minimum.

You order a VTSA valve terminal (type 44) using the order code.

The ordering system for valve terminals starts on page 59.

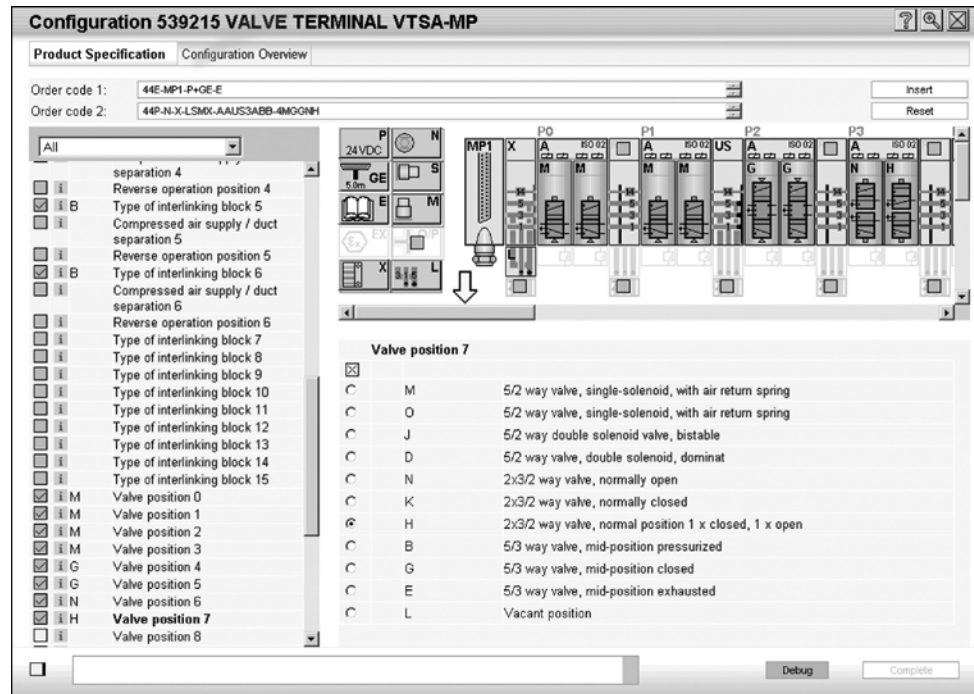

The illustration above provides an example of a valve terminal configuration.

The following steps explain how you use FACE to arrive at the order code:

Once you have called up the Festo home page, select the online version of the digital product catalog from the “Products” submenu: this will bring you directly to the home page for the Pneumatic Catalog. Activate the “Direct Search” menu.

Here you can specify a “Part No.” (e.g. 539215, 539216, 539217 or 539218), the “Type” (e.g. VTSA) or “Article name” (e.g. valve terminal) to find your “Search result”. Click on the blue shopping basket to complete the selected product according to your specifications (this does not initiate an order).

You will then be prompted to configure the product. Select “Configurator”. You can then configure the valve terminal step by step (from the top down) according to your requirements. Select the “Finish” menu to continue on with the ordering process.

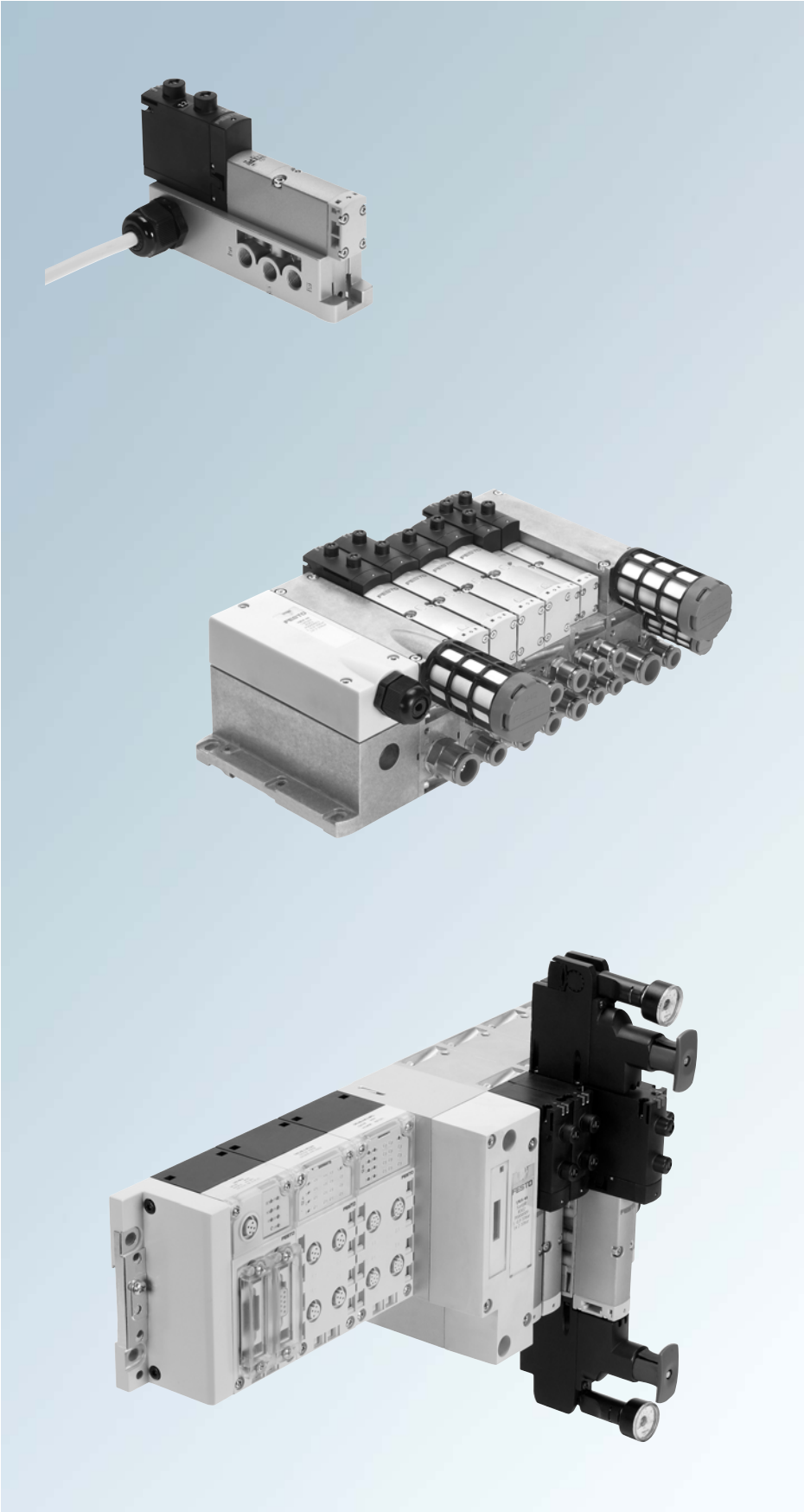

ISO Standard 15407-2

Flow rate up to 1.0 CV
[1,000 l/min]

NPT and G ported
thread connections

24 V DC or 110 V AC solenoids

Combine size 01 with size 02
– Size 01 (26 mm)
– Size 02 (18 mm)

Electrical connections
– Terminal strip or M12
– Multi-pin
– Fieldbus

Overview

Key Features

Valve Terminal

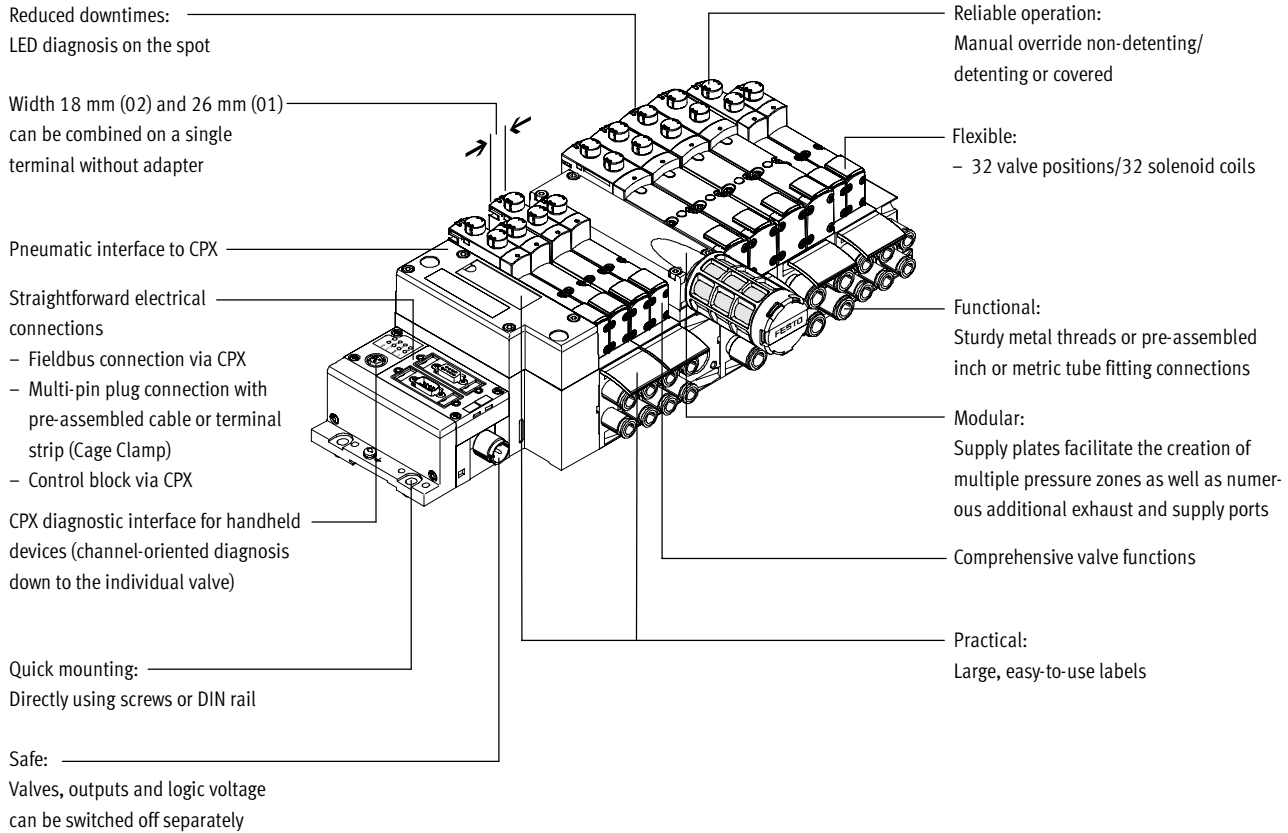

Valve Functions

- 5/2-way valve
 - Single solenoid valve, pneumatic return
 - Single solenoid valve, mechanical spring return
 - Double solenoid valve
 - Double solenoid valve with dominant signal
- 2x 3/2-way valve, single solenoid
 - Normally open
 - Normally open, reversible
 - Normally closed
 - Normally closed, reversible
 - 1x normally open, 1x normally closed
 - 1x normally open, 1x normally closed, reversible
- 5/3-way valve
 - Mid-position pressurized
 - Mid-position closed
 - Mid-position exhausted

Special Features

- | | | | |
|---|---|--|---|
| <p>Multi-pin Plug Terminal</p> <ul style="list-style-type: none"> ■ Max. 32 valve positions/ max. 32 solenoid coils ■ Subbases connected via modular plug-in PCBs ■ Any compressed air supply ■ Any number of pressure zones | <p>Fieldbus Terminal/Control Block</p> <ul style="list-style-type: none"> ■ Max. 32 valve positions/ max. 32 solenoid coils ■ Subbases connected via modular plug-in PCBs ■ Any compressed air supply ■ Any number of pressure zones | <p>Individual Valve</p> <ul style="list-style-type: none"> ■ Electrical connection via standardized 4-pin M12 plug or via 4-pin clamped terminal connection for configuration by the user ■ Available with internal/external pilot air supply | <p>Combinable</p> <ul style="list-style-type: none"> ■ Width 18 mm (02): Valve flow rate up to 500 l/min ■ Width 26 mm (01): Valve flow rate up to 1,000 l/min ■ Width 26 mm (01) and 18 mm (02) can be combined on a single valve terminal |
|---|---|--|---|

Multi-pin Plug or Terminal Strip Connection

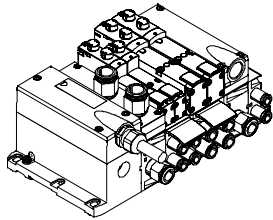

Control signals from the controller to the valve terminal are transmitted via a pre-assembled multi-wire cable or a self-assembled multi-pin plug connection (Cage Clamp), which substantially reduces installation time.

The valve terminals can be fitted with max. 32 valves and max. 32 solenoid coils.

Designs

- Connection with terminal strip (Cage Clamp)
- Pre-assembled multi-pin cable
- Round plug connector M23, 19-pin

Fieldbus Connection via The CPX System

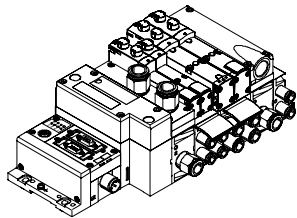

An integrated fieldbus node manages the communication connection to a higher-order PLC. This enables a space-saving pneumatic and electronic solution.

Valve terminals with fieldbus interfaces can be configured with up to 16 manifold subbases. Up to 32 solenoid coils can be actuated.

Designs

- Profibus-DP
- Interbus
- DeviceNet
- Ethernet IP
- CANopen
- CC-Link
- CPX terminal
 - ➔ See CPX Electrical Terminal Product Guide (Info 210)

Control Block Connection via The CPX System

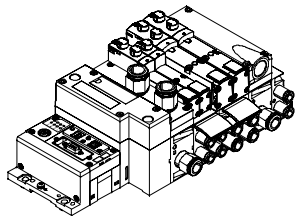

Controllers integrated in the Festo valve terminals permit the construction of stand-alone control units to IP65, without control cabinets.

Using the slave operation mode, these valve terminals can be used for intelligent pre-processing and are therefore ideal modules for designing decentralized intelligence.

In the master operation mode, terminal groups can be designed with many options and functions, which can autonomously control a medium-sized machine/system.

- CPX terminal
 - ➔ See CPX Electrical Terminal Product Guide (Info 210)

Individual Connection

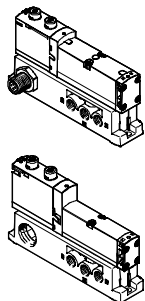

Valves on individual subbases can be used for actuators further away from the valve terminal. The electrical connection is established using a standard 4-pin M12 plug (EN 61076-2-101) or it can be configured by the user with a 4-pin clamped terminal connection.

Overview

Pneumatic Components

Modular Pneumatic Components

The modular design of the VTSA facilitates maximum flexibility right from the planning stage and offers maximum ease of service in operation.

The system consists of manifold subbases and valves. The manifold subbases are screwed together and form the support system for the valves.

Inside, the manifold subbases contain the connection ducts for supplying compressed air to and venting from the valve terminal as well as the working ports for the pneumatic cylinders from each valve.

Each manifold subbase is connected to the next using four screws. Individual terminal sections can be isolated and further blocks inserted by loosening these screws. This ensures that the valve terminal can be rapidly and reliably expanded.

Modularity In The Basic System

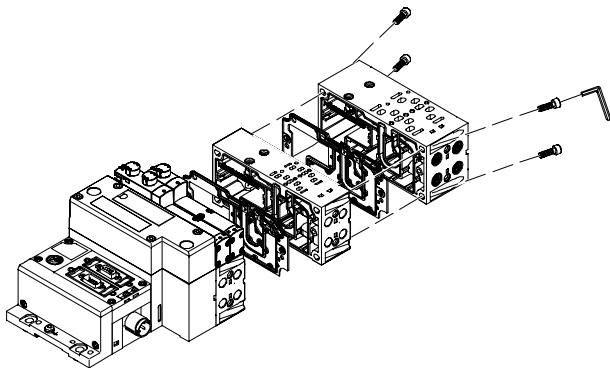

Modularity In The Valves

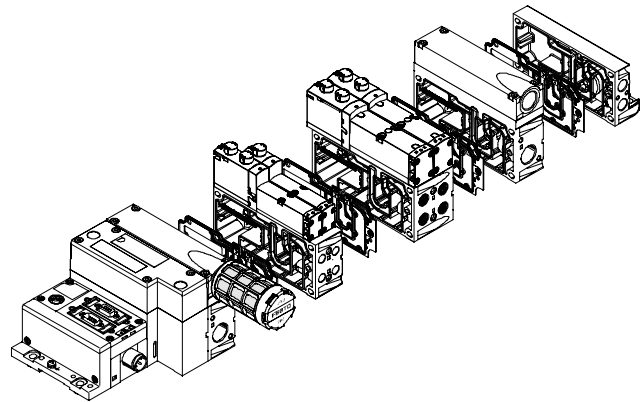

Modularity In The Vertical Stacking

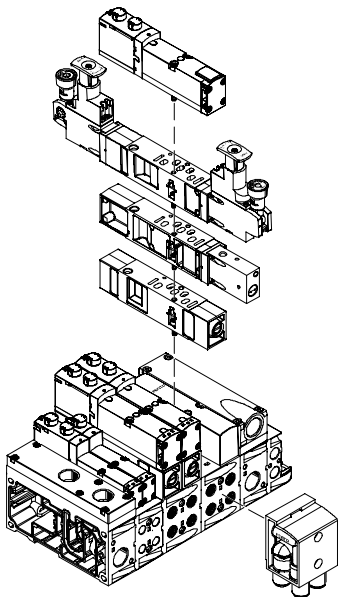

Overview

Electrical Components

Modular Electrical Components

The manner in which the valves are actuated differs according to whether you are using a multi-pin terminal or fieldbus terminal.

The VTSA with CPX interface is based on the internal bus system of the CPX and uses this communication system for all solenoid coils and a range of electrical input and output functions.

Parallel linking facilitates the following:

- Transmission of switching information
- High valve density
- Compact design
- Position-based diagnosis
- Separate voltage supply for valves
- Flexible conversion without address shifting
- Transmission of status, parameter and diagnostic data
- Option of CP interface
- CPX-FEC as autonomous controller with access via Ethernet and web server

VTSA With CPX Electrical Components

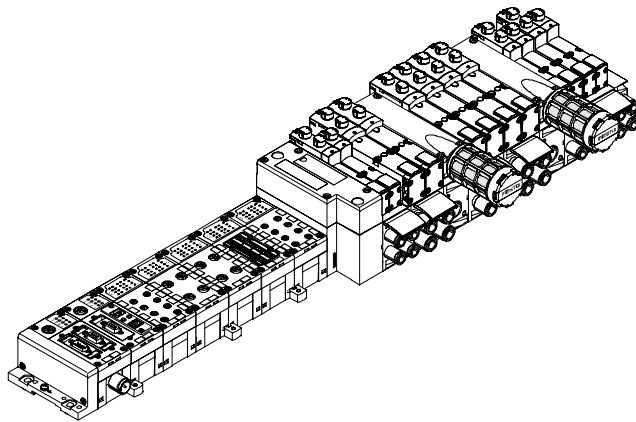

Modularity With CPX Electrical Components

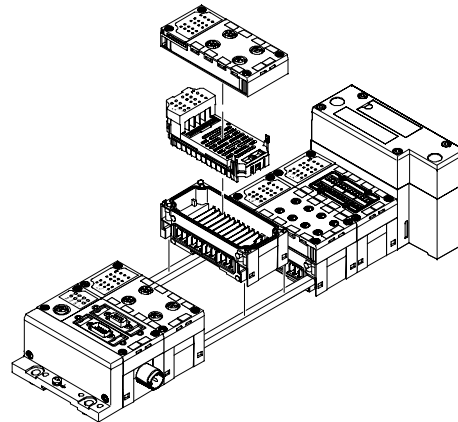

Overview

Multi-pin Connection

Valve Terminal with Multi-pin Plug Connection

Order Code Prefix:

- 44E for the electrical components
- 44P... for the pneumatic components

VTSA valve terminals with multi-pin plug connection can be expanded with up to 32 valves and 32 solenoid coils.

The manifold subbases are either prepared for:

- 2 single solenoid valves
- 2 double solenoid valves

■ Double solenoid valve positions can be equipped with any valve or a blanking plate.

■ Single solenoid valve positions can only be equipped with single solenoid valves or a blanking plate.

The following multi-pin plug connections to IP65 are available:

- 37-pin Sub-D connection (24 V DC):
The connecting cable can be ordered in lengths of 2.5 m, 5 m and 10 m for a maximum of 8, 22 or 32 solenoid coils.
- Terminal strip (24 V DC and 110 V AC)
- 19-pin round plug connector

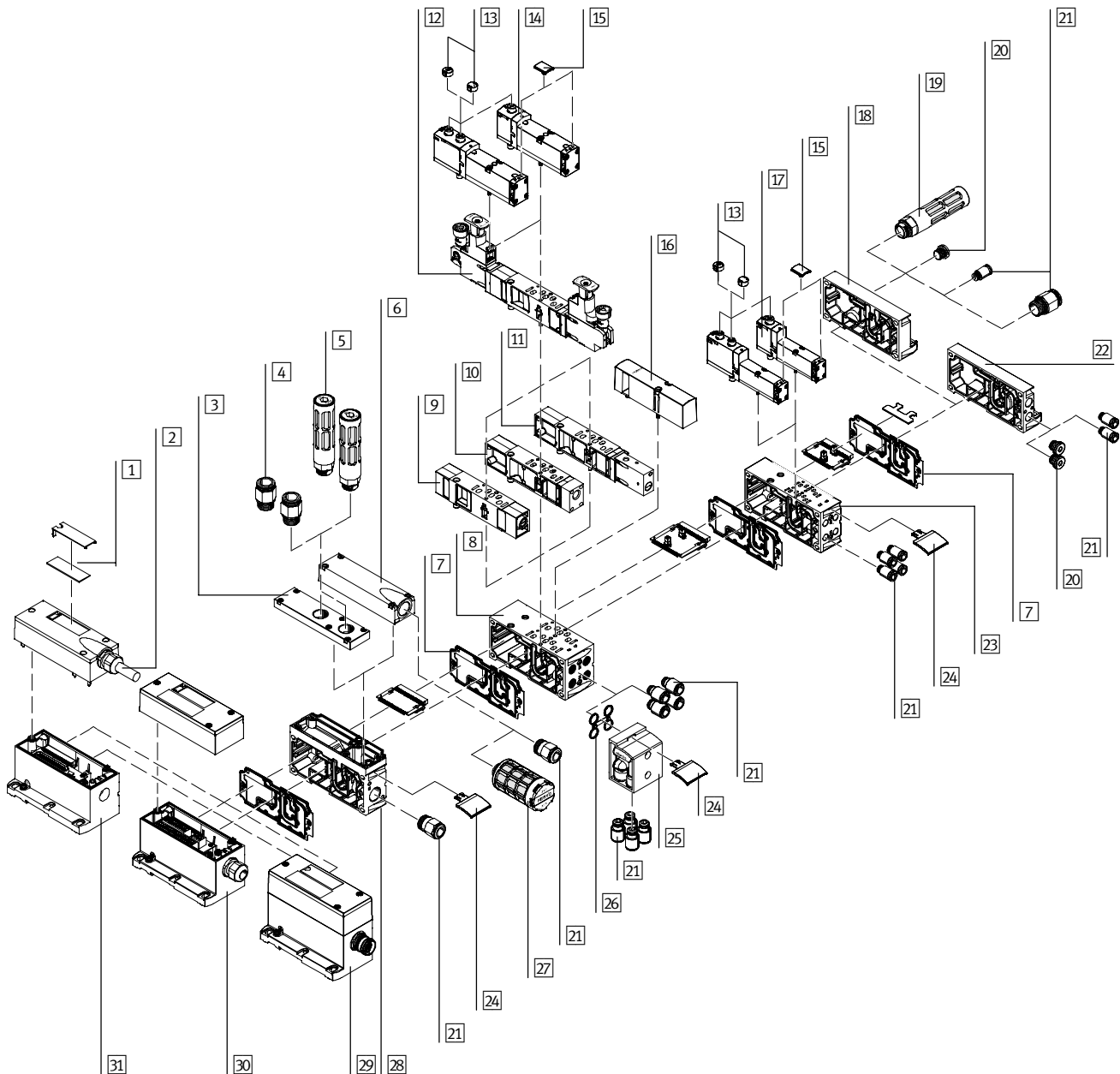

Overview

Multi-pin Connection

Valve Terminal with Multi-pin Plug Connection			
	Description	→ See Page	
1	Labels	Large, for multi-pin plug connection	83
2	Multi-pin cable		82
3	Exhaust port cover	Ports 3 and 5 separated	81
4	Fittings	For supply plate	83
5	Silencer	For supply plate	83
6	Exhaust plate	For ducted exhaust air (ports 3 and 5 combined)	81
7	Separating seal/seal		81
8	Manifold subbase	For valves with a width of 26 mm (01)	80
9	Throttle plate		82
10	Vertical supply plate		81
11	Vertical isolating plate		82
12	Pressure regulator plate		81
13	Cover	For manual override, pushing, covered	83
14	Valve	Width: 26 mm (01)	79
15	Label	For valve	83
16	Blanking plate	For unused valve position (vacant position)	83
17	Valve	Width: 18 mm (02)	79
18	Right-hand end plate		80
19	Silencer	For end plate	83
20	Blanking plug		83
21	Fittings		83
22	Selector end plate		80
23	Manifold subbase	For valves with a width of 18 mm (02)	80
24	Label	For supply plate, subbase, 90° connection plate	83
25	90° connection plate		81
26	Seals		-
27	Silencer		83
28	Supply plate		81
29	Multi-pin plug connection	Via M23 round plug connection	82
30	Multi-pin plug connection	Via terminal strip (Cage Clamp)	82
31	Multi-pin plug connection	With multi-pin cable	82

Valve Terminal with Fieldbus Connection, Control Block (CPX Electrical Peripherals)

Order Code Prefix:

- 50E-... for the electrical peripherals
- 44P-... for the pneumatic components

Valve terminals with fieldbus interfaces can be configured with up to 8 manifold subbases with double solenoid valves and 16 manifold subbases with single solenoid valves. In conjunction with CPX and 8 manifold subbases with double solenoid valves, up to 32 solenoid coils can thus be actuated.

Each valve position can be equipped with any valve or a blanking plate. The rules for CPX apply to the equipment that can be used in combination with CPX electrical peripherals. Up to 32 solenoid coils can thus be actuated.

In general:

- Max. 10 electrical modules
- Digital inputs/outputs
- Analog inputs/outputs
- Parameterization of inputs and outputs
- Integrated high-feature diagnostic system
- Preventive maintenance concepts

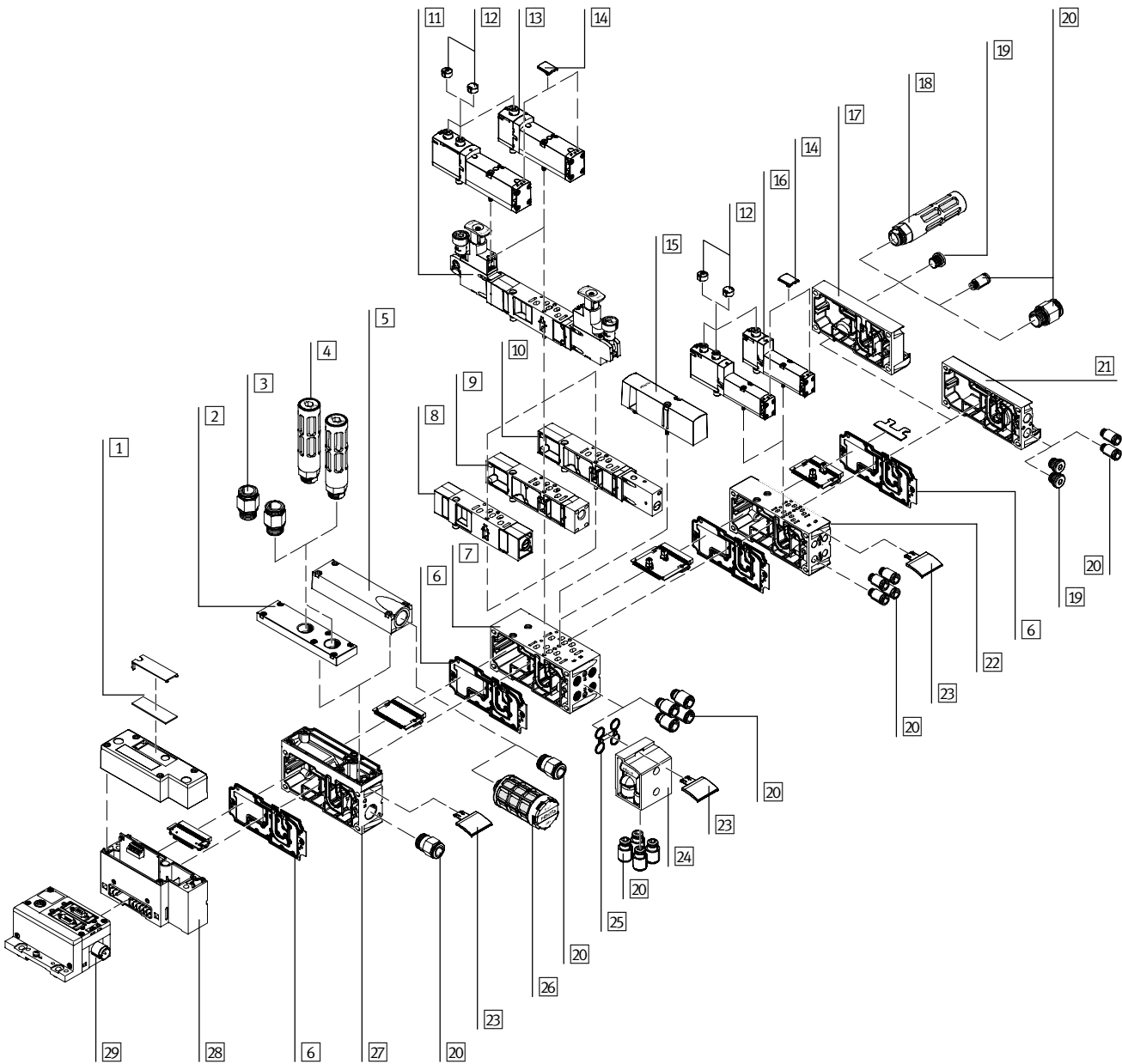

Overview

Fieldbus Connection

Valve Terminal with Fieldbus Connection, Control Block (CPX Electrical Peripherals)			
	Description	→ See Page	
1	Labels	Large, for CPX pneumatic interface	83
2	Exhaust port cover	Ports 3 and 5 separated	81
3	Fittings	For supply plate	83
4	Silencer	For supply plate	83
5	Exhaust plate	For ducted exhaust air (ports 3 and 5 combined)	81
6	Separating seal/seal		81
7	Manifold subbase	For valves with a width of 26 mm (01)	80
8	Throttle plate		82
9	Vertical supply plate		81
10	Vertical isolating plate		82
11	Pressure regulator plate		81
12	Cover	For manual override, pushing, covered	83
13	Valve	Width: 26 mm (01)	79
14	Label	For valve	83
15	Blanking plate	For unused valve position (vacant position)	83
16	Valve	Width: 18 mm (02)	79
17	Right-hand end plate		80
18	Silencer	For end plate	83
19	Blanking plug		83
20	Fittings		83
21	Selector end plate		80
22	Manifold subbase	For valves with a width of 18 mm (02)	80
23	Label	For supply plate/subbase/90° connection plate	83
24	90° connection plate		81
25	Seals		–
26	Silencer		83
27	Supply plate		81
28	Pneumatic interface		82
29	Fieldbus interface		64

Overview

Single Subbases

Individual Subbase

Order Code:

- Use individual part numbers

Individual subbases can be equipped with any valve. The electrical connection is established using a standard 4-pin M12 plug (EN 61076-2-101).

Width: 18 mm (02) with M12 Plug

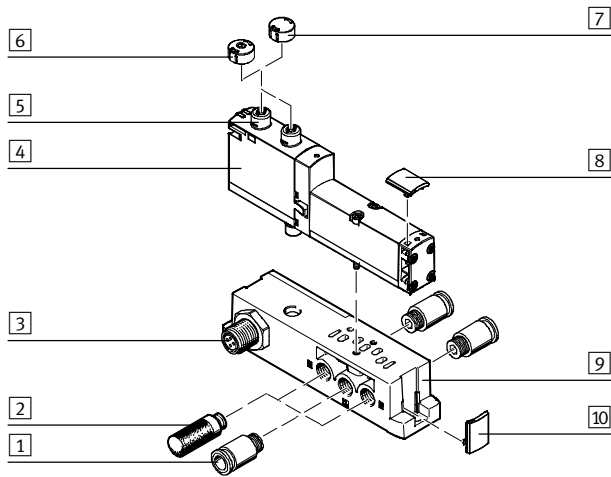

Width: 26 mm (01) with M12 Plug

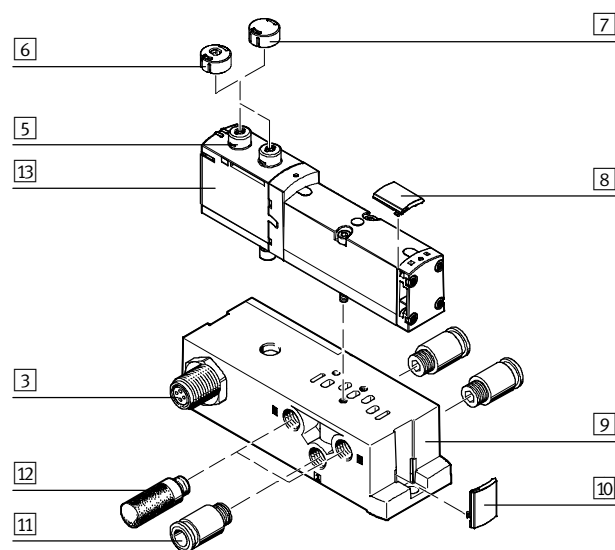

	Description	→ See Page
1	Fitting G $\frac{1}{8}$ or $\frac{1}{8}$ NPT for supply/exhaust ports (1, 3, 5) and working ports (2, 4)	83
2	Silencer G $\frac{1}{8}$ or $\frac{1}{8}$ NPT for supply/exhaust ports (1, 3, 5)	83
3	Electrical connection M12, 4-pin	-
4	VSVA valve Width: 18 mm (02)	79
5	Manual override Non-detenting/detenting, per solenoid coil	-
6	Cover For manual override, non-detenting	83
7	Cover For manual override, covered	83
8	Label For valves	83
9	Individual subbase For valve VSVA	80
10	Label For subbases	83
11	Fitting G $\frac{1}{4}$ or $\frac{1}{4}$ NPT for supply/exhaust ports (1, 3, 5) and working ports (2, 4)	83
12	Silencer G $\frac{1}{4}$ or $\frac{1}{4}$ NPT for supply/exhaust ports (1, 3, 5)	83
13	VSVA valve Width: 26 mm (01)	79

Overview

Single Subbases

Individual Subbase

Order Code:

- Use individual part numbers

Individual subbases can be equipped with any valve. The electrical connection is established using a 4-pin clamped terminal connection.

Width: 18 mm (02) with Clamped Terminal Connection

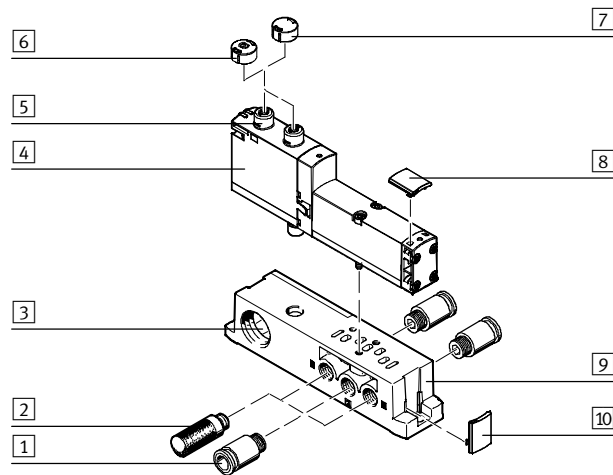

Width: 26 mm (01) with Clamped Terminal Connection

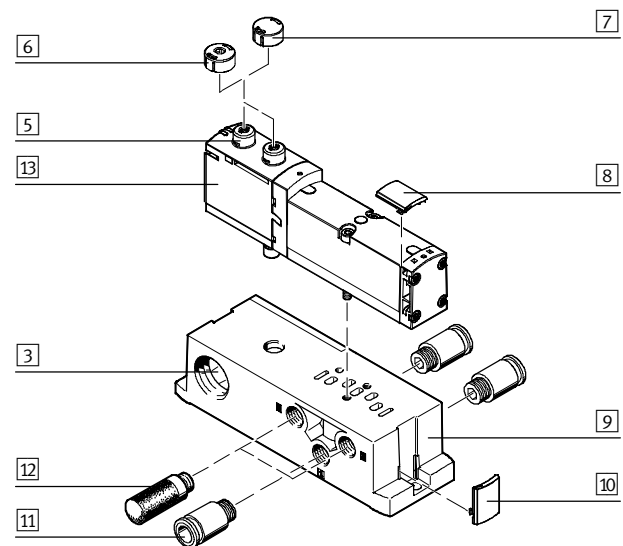

	Description	→ See Page	
1	Fitting	G $\frac{1}{8}$ or $\frac{1}{8}$ NPT for supply/exhaust ports (1, 3, 5) and working ports (2, 4)	83
2	Silencer	G $\frac{1}{8}$ or $\frac{1}{8}$ NPT for supply/exhaust ports (1, 3, 5)	83
3	Electrical connection	Cage Clamp terminal strip	-
4	VSVA valve	Width: 18 mm (02)	79
5	Manual override	Non-detenting/detenting, per solenoid coil	-
6	Cover	For manual override, non-detenting	83
7	Cover	For manual override, covered	83
8	Label	For valves	83
9	Individual subbase	For valve VSVA	80
10	Label	For subbases	83
11	Fitting	G $\frac{1}{4}$ or $\frac{1}{4}$ NPT for supply/exhaust ports (1, 3, 5) and working ports (2, 4)	83
12	Silencer	G $\frac{1}{4}$ or $\frac{1}{4}$ NPT for supply/exhaust ports (1, 3, 5)	83
13	VSVA valve	Width: 26 mm (01)	79

Subbase Valve

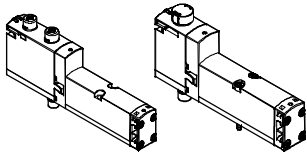

VTSA offers a comprehensive range of valve functions. All valves are equipped with piston spool and patented sealing system which facilitate efficient sealing, a broad pressure range and long service life.

Subbase valves can be quickly replaced since the tubing connections remain on the subbase. Irrespective of the valve function there are subbase valves with one solenoid coil (single solenoid) or with two solenoid coils for double solenoid or double valve functions.

Reverse Operation

Select reverse operation (code Z) if you wish to operate an actuator (cylinder) with different pressures for the forward and return stroke. It must be noted here that these valves must be operated via a separate pressure zone.

Blanking Plate

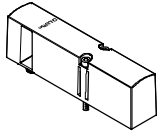

Plate without valve function for reserving valve positions on a valve terminal.

Valves and blanking plates are attached to the manifold subbase using two screws.

Valve Function

Code	Circuit Symbol	Width		Description
		18 mm (02)	26 mm (01)	
M		■	■	5/2-way valve, single solenoid ■ Pneumatic spring return
O		■	■	5/2-way valve, single solenoid ■ Spring return
J		■	■	5/2-way valve, double solenoid
D		■	■	5/2-way valve, double solenoid ■ Dominating signal
N		■	■	2x 3/2-way valve, single solenoid ■ Normally open ■ Pneumatic spring return
K		■	■	2x 3/2-way valve, single solenoid ■ Normally closed ■ Pneumatic spring return

Valve Function				
Code	Circuit symbol	Width		Description
		18 mm (02)	26 mm (01)	
H		■	■	2x 3/2-way valve, single solenoid ■ Normal position – 1x open – 1x closed ■ Pneumatic spring return ■ Operating pressure > 3 bar
B		■	■	5/3-way valve ■ Mid-position pressurized ¹⁾ ■ Spring force return
G		■	■	5/3-way valve ■ Mid-position closed ¹⁾ ■ Spring force return
E		■	■	5/3-way valve ■ Mid-position exhausted ¹⁾ ■ Spring force return
P		■	■	2x 3/2-way valve, single solenoid ■ Reverse operation ■ Normally open ■ Pneumatic spring return
Q		■	■	2x 3/2-way valve, single solenoid ■ Reverse operation ■ Normally closed ■ Pneumatic spring return
R		■	■	2x 3/2-way valve, single solenoid ■ Reverse operation ■ Normal position – 1x open – 1x closed ■ Pneumatic spring return
L		■	■	For valve terminal only: Blanking plate for vacant valve position

1) Mid-position can be reached without electrical signal or using both signals.

Design

Valve Replacement

The valves are attached to the metal manifold subbase using two screws. This means that they can be easily

replaced. The high-quality of the manifold subbase guarantees good long-term sealing tightness.

Expansion

Vacant positions can be equipped with valves at a later date. The dimensions, mounting points and existing pneumatic installations

remain unchanged during this process. The order code V5VA-... is located on the front of the valve beneath the manual override.

Vertical Stacking

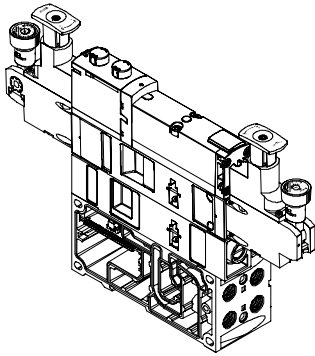

Additional function units can be added to each valve position between the subbase and the valve. These functions, designated as vertical stacking, facilitate special functioning

or control of the respective individual valve position. Combinations of several valve sizes on one valve terminal are possible.

Note

The operation of the components should be checked when combining multiple vertical stacking components.

- The following combination of reversible valve terminals with vertical stacking components is not permitted:
 - Reversible pressure regulating plates
 - Throttle plates
 - Vertical isolating plates
 - Vertical supply plates

Vertical Stacking Components

The following component sequence is recommended for valve positions with vertical stacking:

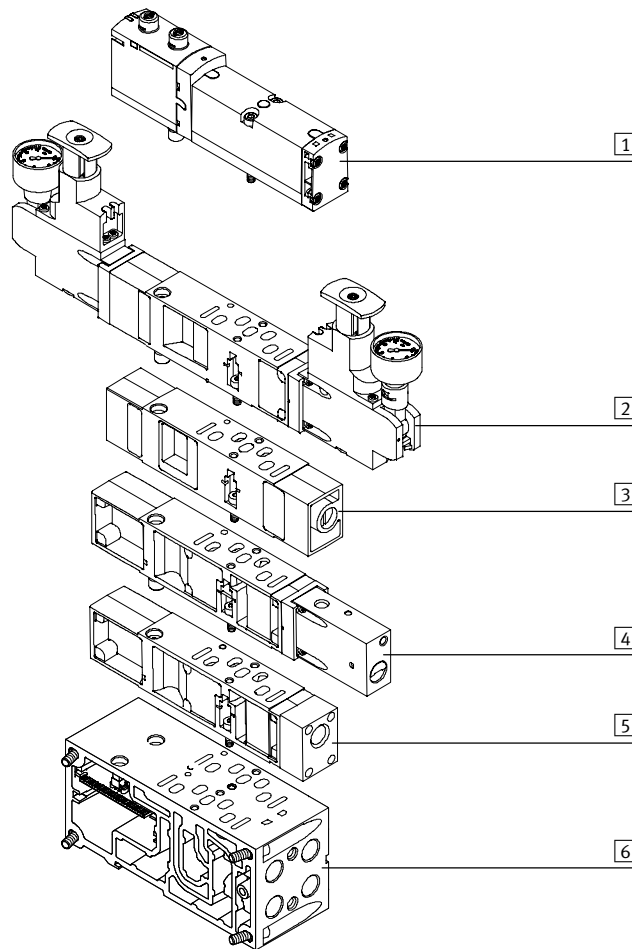

- 1 ISO valve
- 2 Pressure regulator plate
- 3 Throttle plate
- 4 Vertical isolating plate
- 5 Vertical supply plate
- 6 Manifold subbase

Vertical Stacking

Pressure Regulator Plate

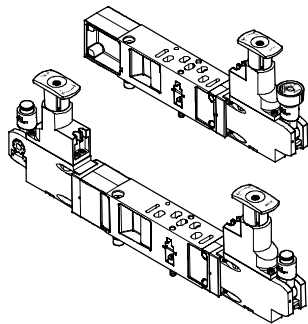

An adjustable pressure regulator can be installed between the subbase and the valve in order to control the force of the respective actuator.

This pressure regulating valve maintains an essentially constant output pressure (secondary side) independent of pressure fluctuations (primary side) and air consumption.

Standard version:

- Standard port pattern to ISO 15407-2
- For output pressure up to 6 bar or up to 10 bar maximum
- Without pressure gauge (optional)
- Regulator knob

Mode of Operation of the Pressure Regulating Plates

Pressure Regulator Plate (P Regulation) for Port 1; Code: ZA, ZF

This pressure regulator regulates the pressure before the valve in duct 1. Ducts 2 and 4 have the same regulated pressure.

During venting, the exhaust flow in the valve is from duct 2 to duct 3 and from duct 4 to duct 5.

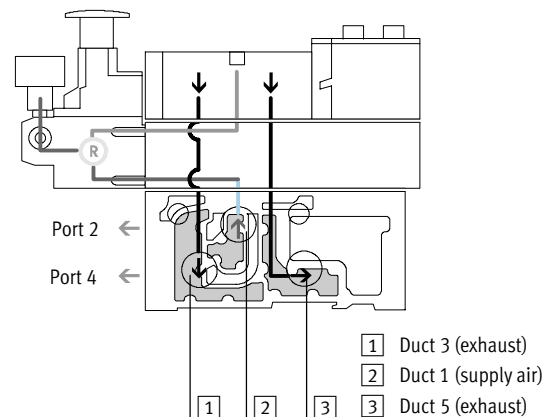

Advantages:

- The pressure regulator is not affected by venting, as the pressure is regulated before the valve.

- The pressure regulator can always be adjusted, as the pressure from the valve terminal is always present.

Sample Applications:

- An equal working pressure is required at working ports 2 and 4 (e.g. 3 bar) than the operating pressure present on the valve terminal (e.g. 8 bar) is required.
- A lower working pressure

Pressure Regulator Plate (A/B Regulation) for Ports 2 and 4; Code: ZD, ZI

This pressure regulator regulates the pressure in ducts 2 and 4 after the pressure medium flows through the valve. During venting, the exhaust flow in the valve is from duct 2 to duct 3 and from duct 4 to duct 5 via the pressure regulator.

Example with the following switching position:
The supply air flows from duct 1 of the manifold subbase via the valve to duct 2, it is then regulated and made available at port 2 of the manifold subbase. At the same time, venting takes place via duct 4 of the manifold subbase, via the regulator and via the valve into duct 5 of the manifold subbase.

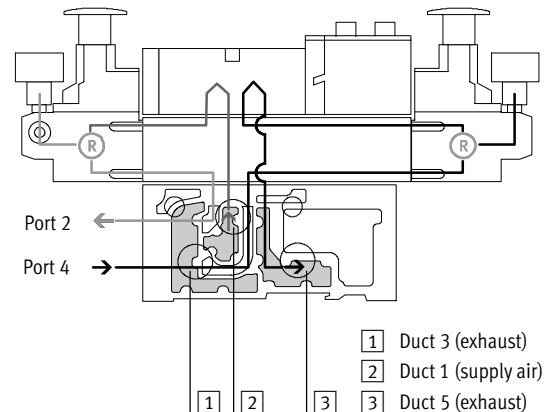

Restrictions:

- The pressure regulator cannot be adjusted in the exhaust position. For example, the pressure regulator for duct 4 cannot be adjusted when

the valve is pressurized in the switching position from duct 1 to duct 2 and exhausted from duct 4 to duct 5.

Application Examples:

- When two different working pressures are required instead of the valve terminal operating pressure at ports 2 and 4.

Vertical Stacking

Mode of Operation of the Pressure Regulating Plates

Pressure Regulator Plate (A/B Regulation, Reversible) for Ports 2 and 4, Reversible; Code: ZE, ZJ

With this pressure regulator, the supply air (duct 1) is split and routed directly to both pressure regulators. The regulated compressed air is present in ducts 3 and 5 on the valve. The valve is thus operated in reversible mode.

This means:

- Duct 3 routes the working pressure to port 2
- Duct 5 routes the working pressure to port 4

Example with the following switching position:

The supply air in duct 1 is split among ducts 3 and 5 in the regulator and flows from here to the valve. In the valve, the supply air is routed to port 2 of the manifold subbase. The exhaust air is simultaneously routed via duct 4 of the manifold subbase and via the valve to regulator duct 1, where it is split between ducts 3 and 5 and then drawn off via the manifold subbase.

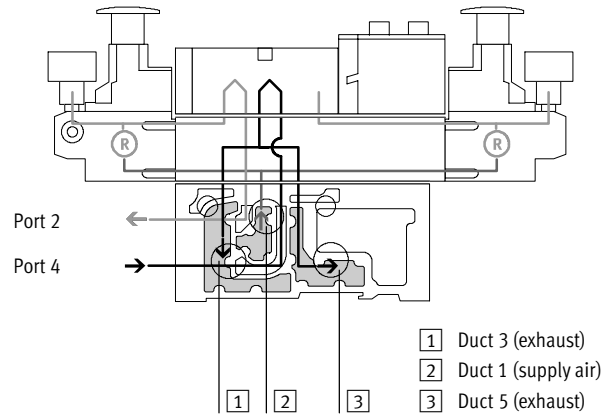

Application Examples:

- When two different pressures are required in ducts 2 and 4 instead of the operating pressure.
- When fast exhaust performance is required.
- When the pressure regulator must always be adjustable.

Note

- Reversible pressure regulating plates may only be combined with valves that can be operated in reversible mode.
- Valves in valve positions with vertical isolating plates are operated with internal pilot air supply, even when the valve terminal is operated with external pilot air supply.

Advantages:

- Fast cycle times.
- 50% higher exhaust flow rate, as air is not exhausted via the pressure regulator. The load on the pressure regulator is also reduced.
- No quick exhaust valves are required.
- Operating pressure is always present at the pressure regulator, as the pressure is regulated before the valve, i.e. the regulator can always be adjusted.

Restrictions:

- 2x 3/2-way valves (code N, K, H) not used, as pressure is present at ports 3 and 5.
- No practical combination with an intermediate throttle plate possible.

Vertical Stacking							
Pressure Regulator Plate							
Code		Type	Width		Max. Output Pressure		Description
			18 mm (02)	26 mm (01)	6 bar	10 bar	
Pressure Regulating Plate for Port 1							
ZA		VABF-S4-...-R1C2-C-10	■	■	-	■	■ Regulates the operating pressure in duct 1 before the directional control valve
ZF		VABF-S4-...-R1C2-C-6	■	■	■	-	
Pressure Regulating Plate for Port 2							
ZC		VABF-S4-...-R2C2-C-10	■	■	-	■	■ Regulates the operating pressure in duct 2 after the directional control valve
ZH		VABF-S4-...-R2C2-C-6	■	■	■	-	
Pressure Regulating Plate for Port 4							
ZB		VABF-S4-...-R3C2-C-10	■	■	-	■	■ Regulates the operating pressure in duct 4 after the directional control valve
ZG		VABF-S4-...-R3C2-C-6	■	■	■	-	
Pressure Regulating Plate for Ports 2 and 4							
ZD		VABF-S4-...-R4C2-C-10	■	■	-	■	■ Regulates the operating pressure in ducts 2 and 4 after the directional control valve
ZI		VABF-S4-...-R4C2-C-6	■	■	■	-	
Pressure Regulating Plate for Ports 2 and 4, Reversible							
ZE		VABF-S4-...-R5C2-C-10	■	■	-	■	<ul style="list-style-type: none"> ■ Reversible pressure regulator for ports 2 and 4 ■ Pressure regulation before the valve ■ Redirects the operating pressure from duct 1 to ducts 3 and 5 ■ Routes the exhaust air from duct 1 to ducts 3 and 5
ZJ		VABF-S4-...-R5C2-C-6	■	■	■	-	

Vertical Stacking

Throttle Plate

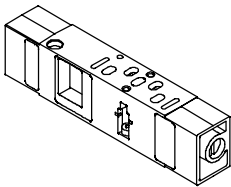

This plate is used for exhaust air flow control in ducts 3 and 5 of a valve in order to adjust the speed of the actuator.

Ducts 3 and 5 can be adjusted independently of each other.

Note

On reversible valve terminals, supply air flow control takes place in ducts 3 and 5 before the valve.

Code	Type	Width		Description
		18 mm (02)	26 mm (01)	
X	VABF-S4-...F1B1-C	■	■	<ul style="list-style-type: none"> Controls the flow of exhaust air after the valve to ducts 3 and 5

Vertical Isolating Plate

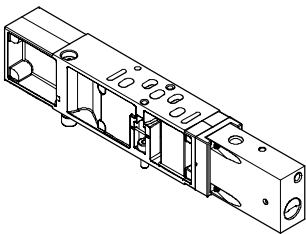

With this plate a valve can be shut off from the supply pressure of the terminal. This means that the valve can be removed without shutting off the pressure.

Following activation of the shutoff, the exhaust air/return air from the cylinder is drawn off via the M5 threaded connection.

Note

The pressure in duct 1 of a manifold where a vertical isolating plate is located must be greater than 3 bar (45 psi).

Code	Type	Width		Description
		18 mm (02)	26 mm (01)	
ZT	VABF-S4-...L1D1-C	■	■	<ul style="list-style-type: none"> 3/2-way valve for shutting off the operating pressure at the valve position Blocks ducts 12 and 14 for the valve position Supplies the valve position with internal pilot air

Vertical Supply Plate

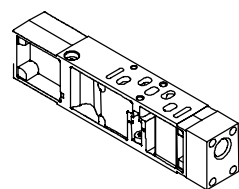

With this plate a valve can be supplied with individual operating pressure independently of the operating pressure of the terminal.

Code	Type	Width		Description
		18 mm (02)	26 mm (01)	
ZU	VABF-S4-...P1A3-...	■	■	<ul style="list-style-type: none"> Plate with port 11 for supplying an individual operating pressure for a valve position

Manifold Subbase

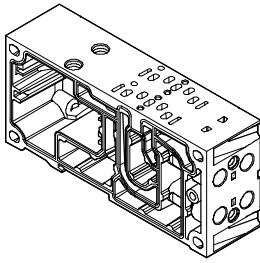

VTSA is based on a modular system which consists of manifold subbases and valves. Manifold subbases are available for valve width 18 mm (02) and width 26 mm (01) in a double grid, i.e. two valves per manifold subbase. The manifold subbase contains a vertical seal and PCB for passing the electrical signal through

the manifold. They can be freely mixed within a valve terminal. The manifold subbases are screwed together and thus form the support system for the valves. Inside, the manifold subbases contain the connecting ducts for supplying compressed air to and venting from the valve terminal as well as the

working ports for the pneumatic cylinders for each valve. Each manifold subbase is connected to the next using four screws. Individual terminal sections can be isolated and further manifold subbases inserted by loosening these screws. This ensures that the valve terminal can be rapidly and reliably expanded.

Manifold Subbase Variants

Code		Type	Width		No. of Valve Positions/ Solenoid coils	Description
			18 mm (02)	26 mm (01)		
Manifold Subbase for Multi-pin Plug/Fieldbus Connection						
For Double Solenoid Valves						
A AK		G Thread: VABV-S4-2S-G18-2T2 NPT Thread: VABV-S4-2S-N18-2T2	■	-	2/4	Working ports (2, 4) on manifold subbase ■ Connection sizes for 18 mm width: G $\frac{1}{8}$, QS-G $\frac{1}{8}$ -8, QS-G $\frac{1}{8}$ -6 1/8 NPT, QS-1/8-5/16-U, QS-1/8-1/4-U
B BK		G Thread: VABV-S4-1S-G14-2T2 NPT Thread: VABV-S4-1S-N14-2T2	-	■	2/4	Working ports (2, 4) on manifold subbase ■ Connection sizes for 26 mm width: G $\frac{1}{4}$, QS-G $\frac{1}{4}$ -10, QS-G $\frac{1}{4}$ -8 1/4 NPT, QS-1/4-3/8-U, QS-1/4-5/16-U
For Single Solenoid Valves						
E EK		G Thread: VABV-S4-2S-G18-2T1 NPT Thread: VABV-S4-2S-N18-2T1	■	-	2/2	Working ports (2, 4) on manifold subbase ■ Connection sizes for 18 mm width: G $\frac{1}{8}$, QS-G $\frac{1}{8}$ -8, QS-G $\frac{1}{8}$ -6 1/8 NPT, QS-1/8-5/16-U, QS-1/8-1/4-U
F FK		G Thread: VABV-S4-1S-G14-2T1 NPT Thread: VABV-S4-1S-N14-2T1	-	■	2/2	Working ports (2, 4) on manifold subbase ■ Connection sizes for 26 mm width: G $\frac{1}{4}$, QS-G $\frac{1}{4}$ -10, QS-G $\frac{1}{4}$ -8 1/4 NPT, QS-1/4-3/8-U, QS-1/4-5/16-U

90° Connection Plate

Code		Type	Width		Connections	Description
			18 mm (02)	26 mm (01)		
P		G Thread: VABF-S4-...-A2G2-G...	■	■	2, 4	Outlet at bottom Working ports (2, 4) in the 90° connection plate ■ Connection sizes for 18 mm width: G $\frac{1}{8}$, 1/8NPT ■ Connection sizes for 26 mm width: G $\frac{1}{4}$, 1/4NPT
O		NPT Thread: VABF-S4-...-A2G2-N...	■	■	2, 4	Outlet on top Working ports (2, 4) in the 90° connection plate ■ Connection sizes for 18 mm width: G $\frac{1}{8}$, 1/8NPT ■ Connection sizes for 26 mm width: G $\frac{1}{4}$, 1/4NPT

Compressed Air Supply and Venting

Right-hand End Plate
– Code V

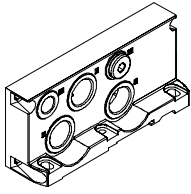

Right-hand End Plate
– Code X

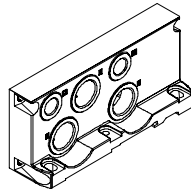

Right-hand End Plate (Selector Style)
– Codes Y, U, Z, W

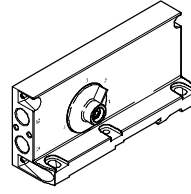

Supply Plate with
Separate 3/5 Exhaust
– Code K

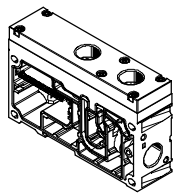

Supply Plate with
Common 3/5 Exhaust
– Code L

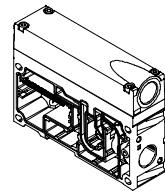

The VTSA valve terminal can be supplied with compressed air at one or more points. This is a reliable way of ensuring that all functional components of the terminal will always offer good performance, even with large-scale expansions. The valve terminal is supplied via supply plates or via an end plate. The valve terminals can be equipped with up to 16 supply plates. Venting is performed by using either silencers or ports for ducted exhaust air. The vents are located on the supply plates and/or on the right-hand end plate. There are two types of supply plates: exhaust port 3/5 common or exhaust 3/5 port separated.

Pilot Air Supply

The port for the pneumatic supply is located on the supply plates or the right-hand end plate. The ports differ for the following types of pilot air supply:

- Internal
- External

Internal Pilot Air Supply

Internal pilot air supply can be selected if the required working pressure is between 3 and 10 bar. The pilot air supply is then branched from the compressed air supply 1 using an internal connection. Port 14 on the right-hand end plate is sealed with a blanking plug.

External Pilot Air Supply

If the supply pressure is less than 3 bar, you must operate your VTSA valve terminal using external pilot air supply. The pilot air supply is supplied via port 14 on the right-hand end plate to this end. This is the case even if the valve terminal is operated with different pressure zones.

Note

If a gradual pressure buildup in the system using a pressurized on-off (soft-start) valve is required, external pilot supply air where the control pressure applied during switch-on is already present should be selected.

Right-hand End Plate

Different right-hand end plates are available.

With the following two end plates, the outgoing direction of the ports is aligned with the horizontal stacking direction.

Right-hand end plates with supply air/ exhaust air

- Internal pilot air supply: code V
- External pilot air supply: code X

With selector end plates, the outgoing direction of the ports is to the front side of the valve terminal. This means that all of the ports on the terminal can be combined in one outgoing direction.

The special feature of the selector end plates is the selector switch, which has four settings for different pilot air supply/pilot exhaust air.

Selector end plates with selector switch set at the factory for:

- Internal pilot air supply: code Y
- External pilot air supply: code Z
- Internal pilot air supply, ducted pilot exhaust air: code U
- External pilot air supply, ducted pilot exhaust air: code W

Note

The selector end plate must be used in combination with a supply plate. The reversible 3/2-way valves (codes P, Q, R) must only be operated in selector position 1 or 2 (codes Z, Y).

Right-hand End Plate					
Code	Type of Compressed Air Supply and Pilot Air Supply	Width		Description	
		18 mm (02)	26 mm (01)		
Right-hand End Plate					
V			■	■	Supply air/exhaust air, internal pilot air supply, silencer ■ Pilot air supply is branched internally from port 1 ■ Port 14 is sealed with a blanking plug ■ Exhaust 3/5 via silencer ■ For operating pressure in the range 3 ... 10 bar ■ Pilot exhaust ¹⁾
X			■	■	Supply air/exhaust air, external pilot air supply, silencer ■ Pilot air supply between 3 ... 10 bar is connected at port 14 ■ Exhaust 3/5 via silencer ■ For operating pressure in the range -0.9 ... 10 bar (suitable for vacuum) ■ Pilot exhaust ¹⁾
Selector End Plate					
Y (2)			■	■	Internal pilot air supply ¹⁾ ■ Pilot air supply is branched internally from port 1 ■ Ports 1/12/14 are internally connected ■ Ports 12/14 are sealed with blanking plugs ■ Pilot exhaust air is vented via valve housing ■ For operating pressure in the range 3 ... 10 bar
U (4)			■	■	Internal pilot supply air, ducted exhaust air ■ Pilot air supply is branched internally from port 1 ■ Ports 1/14 are internally connected ■ Port 14 is sealed with a blanking plug ■ Pilot exhaust via port 12 with silencer ²⁾ ■ For operating pressure in the range 3 ... 10 bar
Z (1)			■	■	External pilot air supply ■ Pilot air supply between 3 ... 10 bar is connected at port 14 ■ Port 12 is sealed with a blanking plug ■ Ports 12/14 are internally connected ■ Pilot exhaust air is vented via valve housing
W (3)			■	■	External pilot supply air, ducted exhaust air ■ Pilot air supply between 3 ... 10 bar is connected at port 14 ■ Pilot exhaust via port 12 with silencer ²⁾

1) Configuration not used for Festo valves.

2) Ducted pilot exhaust air is only possible with turned seals on the valve.

Compressed Air Supply/Duct Separation

Additional supply plates can be used for larger terminals or to create pressure zones. These can be selected at any point before or after manifold subbases.

VTSA with Ducted Exhaust Air

With ducted exhaust air, venting can be performed via a supply plate or a right-hand end plate (code V or X).

- Supply plates contain the ports:
- Compressed air supply port (1)
 - Exhaust port (3/5) common or separated

Depending on your order, the exhaust air ducts are either ducted or vented via silencers.

If a separating seal is required, there are three different options:

- Duct separation 1, 3, 5: code S
- Duct separation 1: code T
- Duct separation 3, 5: code R

If a combination of separating seal (S, T or R) and one or two supply plates is required, the following variants can be selected:

- Supply plate with duct separation on the left-hand side: code SU, TU, RU
- Supply plate with duct separation on the right-hand side: US, UT, UR
- 2 supply plates with intermediate duct separation: code USU, UTU, URU

Supply Plates					
Code	Image	Type	Width		Description
			18 mm (02)	26 mm (01)	
U		<ul style="list-style-type: none"> ■ Exhaust port 3/5 common For threaded connection: VABF-S6-10-P1A7-G12 For NPT thread: VABF-S6-10-P1A7-N12 ■ Exhaust air 3/5 separated For threaded connection: VABF-S6-10-P1A6-G12 For NPT thread: VABF-S6-10-P1A6-N12 	■	■	Supply plate without separating seal (no R, S or T selected)
SU TU RU			■	■	Supply plate with separating seal on left, if R, S or T selected
US UT UR			■	■	Supply plate with separating seal on right, if R, S or T selected
USU UTU URU			■	■	Two supply plates with separating seal in center, if R, S or T selected

Pneumatic Components

Air Supply

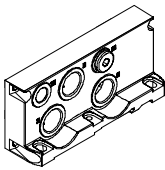
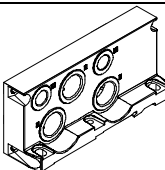
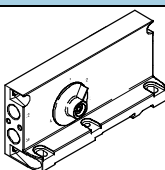
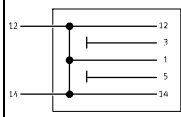
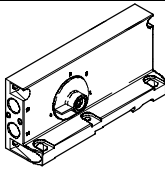
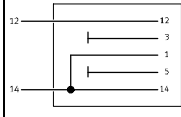
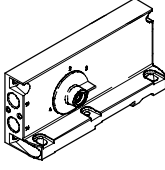
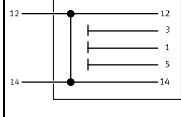
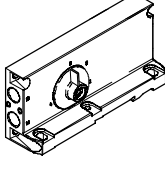
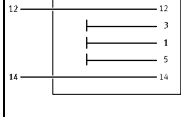
Configuration of All Pneumatic Connections, G Thread							
Code			Connection	Designation	Code M Push-in Connector Large	Code N Push-in Connector Small	
Right-hand End Plate							
V		-	Internal Pilot Air Supply, Silencer				
			1	Compressed air/ vacuum supply	Push-in fitting	QS-G1/2-16	QS-G1/2-12
			3/5	Exhaust air	Via silencer	U-1/4	U-1/4
			12/14	Pilot air supply/ pilot exhaust air	-	-	
X		-	External Pilot Air Supply, Silencer				
			1	Compressed air/ vacuum supply	Push-in fitting	QS-G1/2-16	QS-G1/2-12
			3/5	Exhaust air	Via silencer	U-1/4	U-1/4
			12/14	Pilot air supply/ pilot exhaust air	-	-	
Selector End Plate							
Y (2)			Internal Pilot Air Supply				
			12/14	Pilot air supply/ pilot exhaust air	Blanking plug/push-in fitting	B-1/4 / QS-G1/4-10	B-1/4 / QS-G1/4-8
U (4)			Internal Pilot Air Supply, Ducted Exhaust Air				
			12/14	Pilot air supply/ pilot exhaust air	Blanking plug/blanking plug	B-1/4 / B-1/4	B-1/4 / B-1/4
Z (1)			External Pilot Air Supply				
			12/14	Pilot air supply/ pilot exhaust air	Push-in fitting or silencer/ push-in fitting	QS-G1/4-10 or U-1/4 / QS-G1/4-10	QS-G1/4-8 or U-1/4 / QS-G1/4-8
W (3)			External Pilot Air Supply, Ducted Exhaust Air				
			12/14	Pilot air supply/ pilot exhaust air	Push-in fitting or silencer/ blanking plug	QS-G1/4-10 or U-1/4 / B-1/4	QS-G1/4-8 or U-1/4 / B-1/4

Note: number callouts appear on the end plate.

Configuration of All Pneumatic Connections, NPT Thread							
Code		Connection	Designation	Code M Push-in Connector Large	Code N Push-in Connector Small		
Right-hand End Plate							
V		-	Internal Pilot Air Supply, Silencer				
			1	Compressed air/ vacuum supply	Push-in fitting	QS-1/2-5/8-U	QS-1/2-1/2-U
			3/5	Exhaust air	Via silencer	U-1/4-B-NPT	U-1/4-B-NPT
		12/14	Pilot air supply/ pilot exhaust air	-	-		
X		-	External Pilot Air Supply, Silencer				
			1	Compressed air/ vacuum supply	Push-in fitting	QS-1/2-5/8-U	QS-1/2-1/2-U
			3/5	Exhaust air	Via silencer	U-1/4-B-NPT	U-1/4-B-NPT
		12/14	Pilot air supply/ pilot exhaust air	Push-in fitting	-		
Selector End Plate							
Y (2)			Internal Pilot Air Supply				
			12/14	Pilot air supply/ pilot exhaust air	Blanking plug/push-in fitting	B-1/4-NPT / B-1/4-NPT	B-1/4-NPT / B-1/4-NPT
U (4)			Internal Pilot Air Supply, Ducted Exhaust Air				
			12/14	Pilot air supply/ pilot exhaust air	Blanking plug/blanking plug	QS-1/4-3/8-U or U-1/4-B-NPT / B-1/4-NPT	QS-1/4-5/16-U or U-1/4-B-NPT / B-1/4-NPT
Z (1)			External Pilot Air Supply				
			12/14	Pilot air supply/ pilot exhaust air	Push-in fitting or silencer/ push-in fitting	B-1/4-NPT / QS-1/4-3/8-U	B-1/4-NPT / QS-1/4-5/16-U
W (3)			External Pilot Air Supply, Ducted Exhaust Air				
			12/14	Pilot air supply/ pilot exhaust air	Push-in fitting or silencer/ blanking plug	QS-1/4-3/8-U or U-1/4-B-NPT / QS-1/4-3/8-U	QS-1/4-5/16-U or U-1/4-B-NPT / QS-1/4-5/16-U

Note: number callouts appear on the end plate.

Pneumatic Components

Pressure Zones

Creation of Pressure Zones and Separation of Exhaust Air

The valve terminal VTSA offers a number of options for creating pressure zones if different working pressures are required.

Pressure zones are created by isolating the internal supply ducts between the manifold subbases using an appropriate separating seal.

Compressed air is supplied and vented via a supply plate.

The position of the supply plates and separating seals can be freely selected for VTSA.

Separating seals are integrated from the factory as per your order.

Separating seals can be distinguished through their coding, even when the valve terminal is assembled.

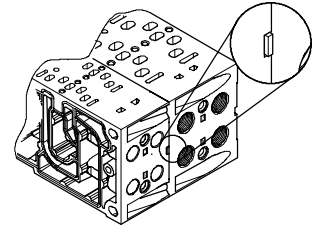

Creating Pressure Zones

Code	Separating Seal	Coding	Width		Description
			18 mm (02)	26 mm (01)	
T			■	■	Duct 1 separated
S			■	■	Duct 1 and 3/5 separated
R			■	■	Duct 3/5 separated

Examples: Compressed Air Supply and Pilot Air Supply, Right-hand End Plate

Internal Pilot Air Supply, Silencer/Ducted Exhaust Air

Right-hand End Plate

- Code V

The diagram shows an example for the configuration and connection of the compressed air supply with internal pilot supply air. Port 14 on the right-hand end plate is tightly sealed. Exhaust air 3/5 is ducted or drawn off via the silencer. Separating seals can be used optionally to create pressure zones.

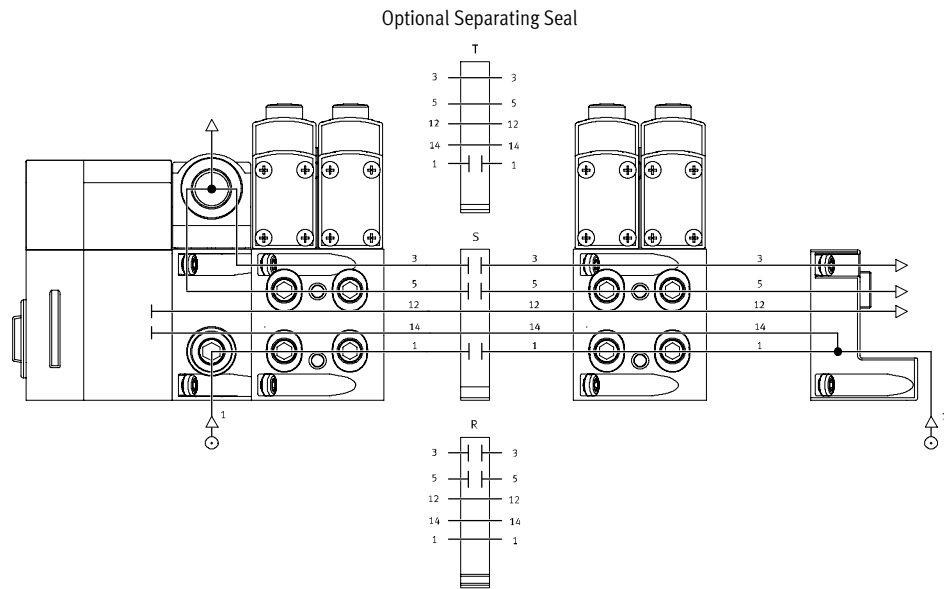

External Pilot Air Supply, Silencer/Ducted Exhaust Air

Right-hand End Plate

- Code X

The diagram shows an example for the configuration and connection of the compressed air supply with external pilot supply air. Port 14 on the right-hand end plate is equipped with a fitting for this. Exhaust air 3/5 is ducted or drawn off via the silencer. Separating seals can be used optionally to create pressure zones.

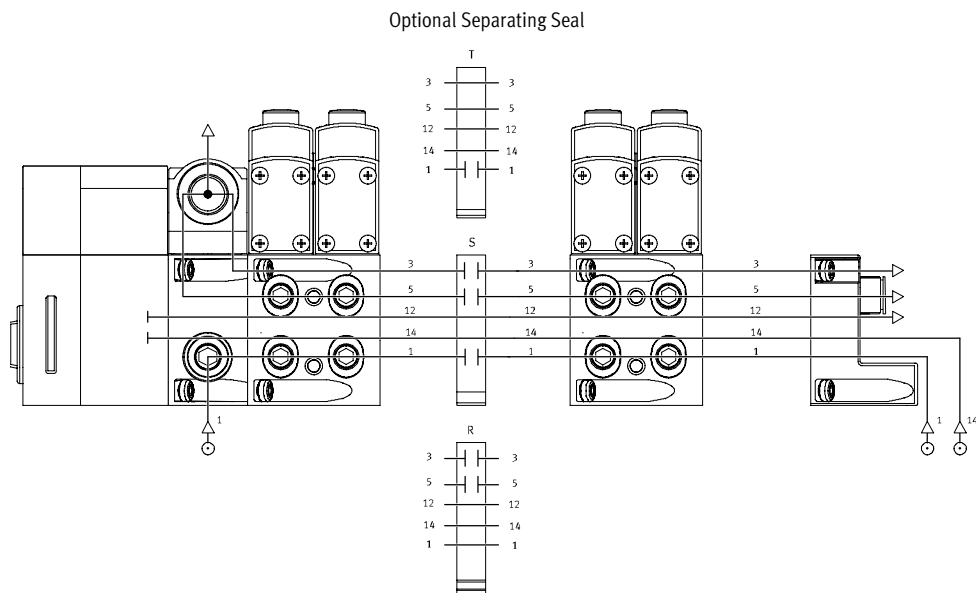

Examples: Compressed Air Supply and Pilot Air Supply via Selector End Plate

Internal Pilot Air Supply, Ducted Exhaust Air/Silencer

Right-hand End Plate

- Code W Shown

The diagram shows an example for the configuration and connection of the compressed air supply with internal pilot supply air. Port 14 on the right-hand end plate is tightly sealed. Exhaust air 3/5 is ducted or drawn off via the silencer. Separating seals can be used optionally to create pressure zones.

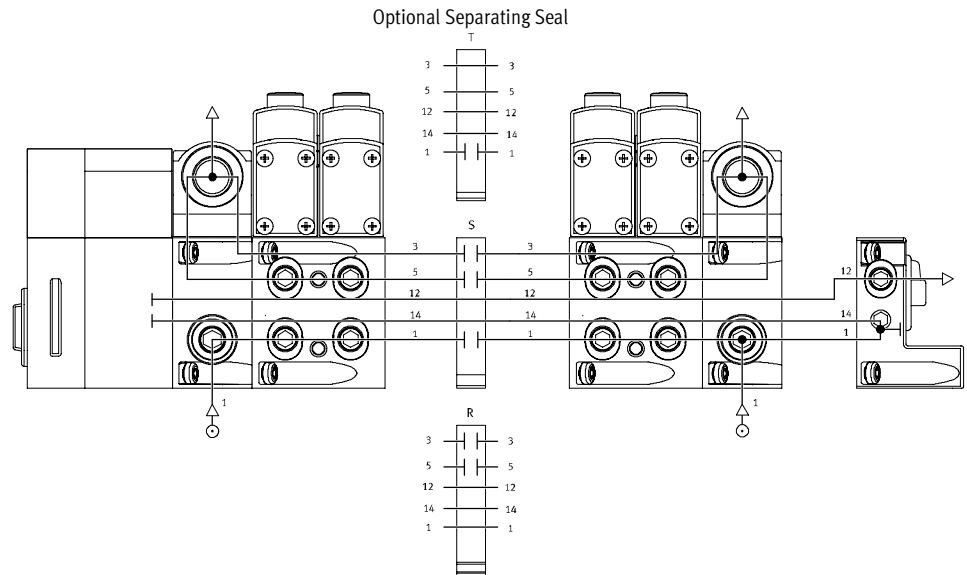

External Pilot Air Supply, Ducted Exhaust Air/Silencer

Right-hand End Plate

- Code Z Shown

The diagram shows an example for the configuration and connection of the compressed air supply with external pilot supply air. Port 14 on the right-hand end plate is equipped with a fitting for this. Exhaust air 3/5 is ducted or drawn off via the silencer. Separating seals can be used optionally to create pressure zones.

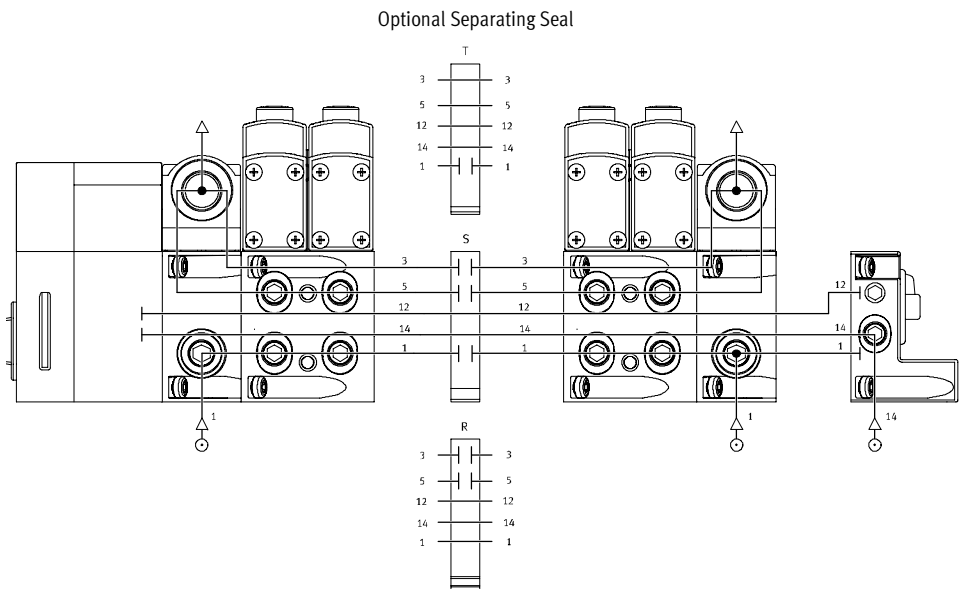

Examples: Creation of Pressure Zones

VTSA with CPX Terminal Connection

VTSA facilitates the creation of up to 16 pressure zones. The diagram shows an example for the configuration and connection of three pressure zones using separating seals – with internal pilot air supply.

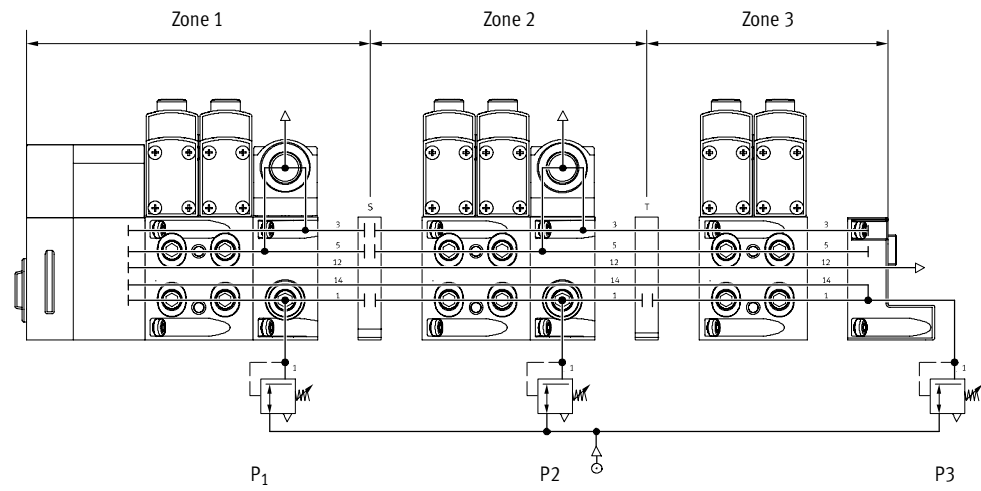

Individual Valve

Valves can also be used on individual subbases for actuators further away from the valve terminal.

■ Electrical M12 connector, 4 pin

■ 4-pin cage clamp terminal connection for configuration by the user

Electrical Multi-pin Plug Connection

The following multi-pin plug connection variants are offered for the VTSA valve terminal:

■ Sub-D multi-pin plug connection (37-pin for 24 V DC): This valve terminal is available with 2 ... 16 valve positions equipped with double solenoid valves and 2 ... 32 valve positions equipped with single solenoid valves. A maximum of 32 solenoid coils can be actuated.

■ Terminal box (terminal strip for 24 V DC or 110 V AC): This valve terminal is available with 2 ... 16 valve positions equipped

with double solenoid valves and 2 ... 32 valve positions equipped with single solenoid valves. A maximum of 32 solenoid coils can be actuated.

■ Multi-pin node (round plug connector): Electrical multi-pin plug connection with round plug connector, 19-pin to CNOMO E03.62.530.N, connecting thread M23 for 24 V DC. The valve terminals can be fitted with max. 16 solenoid coils.

The valves are switched by means of positive or negative logic (PNP or NPN). Mixed operation is not permitted.

Each pin on the Sub-D multi-pin plug or terminal box (terminal strip) can actuate exactly one solenoid coil. If the maximum configurable number of valve positions is 32, this means that 32 valves can be addressed via a single solenoid coil. With 16 or less valve positions, 2 valve solenoid coils per valve can be addressed.

Note

Use the following 37-pin connecting cables from Festo to connect the VTSA valve terminal with Sub-D multi-pin plug connection:

- NEBV-S1W37-...-LE10 for max. 8 solenoid coils
- NEBV-S1W37-...-LE26 for max. 22 solenoid coils
- NEBV-S1W37-...-LE37 for max. 32 solenoid coils

Fieldbus Connection/Control Block

All functions and features of the CPX electrical peripherals are permitted in connection with the CPX interface.

This means:

■ The valves and electrical outputs are supplied via the operating voltage connection of the CPX

■ The valves are supplied and disconnected separately via a separate port on the CPX

Note

Further information can be found in → See CPX Electrical Terminal Product Guide (Info 210)

Solenoid Addressing

Rules For Addressing

– Address allocation is independent of whether blanking plates or subbases are used.

– The addresses are allocated in ascending consecutive order from left to right, while the addresses of the individual valve positions are allocated from front to back.

– A valve position for activating a solenoid coil occupies one address.
– A valve position for activating two solenoid coils occupies two

addresses. The following allocation applies in this case:

- Coil 14: Less significant address
- Coil 12: Higher-value address

Address Assignment of the Valves

Valve terminal with 8 valve locations (top view).

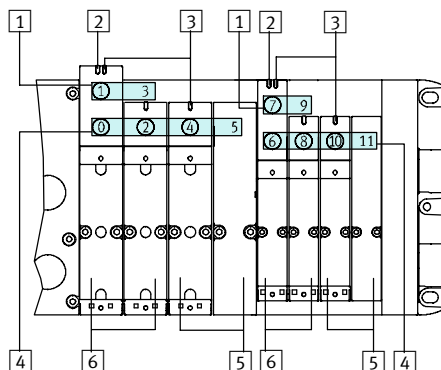

Note: Addresses may be shifted if valve terminal is extended.

- [4] Assigned addresses of coils 14
- [1] Assigned addresses of coils 12
- Address assignment doesn't depend on whether blanking plates/valve plates are fitted.
- Addresses should be assigned in ascending order from left to right, on the individual valve locations from the front to the rear (front = the manifold side with outlet ports).
- [5] A valve location for controlling one coil occupies one address (color of coil contact in the subbase is red).
- [6] A valve location for controlling two coils occupies two addresses (color of coil contacts in the subbase are black). The following assignment applies.
 - Lower-value address of coil 14
 - Higher-value address of coil 12

Assignment of LEDs to the Coils:

- [2] LED for coil 12
- [3] LED for coil 14

Electrical Components

Pin Allocation – Sub-D Plug

Pin Allocation – Sub-D plug, 24 V DC; Electrical Actuator Code MP1							
	Pin ²⁾	Address/Coil	Wire Color ¹⁾		Pin ²⁾	Address/Coil	Wire Color ¹⁾
	1	0	WH		17	16	WH PK
	2	1	BN		18	17	PK BN
	3	2	GN		19	18	WH BU
	4	3	YE		20	19	BN BU
	5	4	GY		21	20	WH RD
	6	5	PK		22	21	BN RD
	7	6	BU		23	22	GY GN
	8	7	RD		24	23	YE GY
	9	8	GY PK		25	24	PK GN
	10	9	RD BU		26	25	YE PK
	11	10	WH GN		27	26	GN BU
	12	11	BN GN		28	27	YE BU
	13	12	WH YE		29	28	GN RD
	14	13	YE BN		30	29	YE RD
	15	14	WH GY		31	30	GN BK
	16	15	GY BN		32	31	GY BU
Note The drawing shows the view on the Sub-D socket at the multi-pin cable end NEBV-S1W37-....	Conductor						
	33	0 V ³⁾	YE BK		35	0 V ³⁾	BN BK
	34	0 V ³⁾	WH BK		36	0 V ³⁾	BK
	Earthing						
37	FE	VT		-	-	-	

- 1) To IEC 757
- 2) Pin 9 ... 35: Not available with cable NEBV-S1-W37-...-10
Pin 23 ... 33: Not available with cable NEBV-S1-W37-...-26
- 3) 0 V for positive switching control signals; connect 24 V for negative switching control signals; mixed operation is not permitted.

Dimensions Download CAD data → www.festo.com/en/engineering

Multi-pin Cable NEBV-S1W37-...

1 Cable conduit fitting M20x1.5

The wire colors refer to the following pre-assembled multi-pin cables from Festo:

- NEBV-S1W37-...-10 for valve terminal with max. 8 solenoid coils
- NEBV-S1W37-...-26 for valve terminal with max. 22 solenoid coils
- NEBV-S1W37-...-37 for valve terminal with max. 32 solenoid coils

Electrical Components

Sub-D Plug – Ordering Information

Sub-D plug, 24 V DC; Electrical Actuation Code MP1							
Type	Sheath	Length [m]	Wire x mm ² [mm ²]	Cable Ø [mm]	Part No.		
NEBV-S1W37-E2.5-LE10	Polyurethane ¹⁾ (PUR)	2.5	10 x 0.34	7.7	539240		
NEBV-S1W37-E5-LE10		5			539241		
NEBV-S1W37-E10-LE10		10			539242		
NEBV-S1W37-E2.5-LE26		Polyurethane ¹⁾ (PUR)	2.5	26 x 0.34	11.5	539243	
NEBV-S1W37-E5-LE26			5			539244	
NEBV-S1W37-E10-LE26			10			539245	
NEBV-S1W37-K2.5-LE37			Polyurethane ¹⁾ (PUR)	2.5	37 x 0.34	13	539246
NEBV-S1W37-K5-LE37				5			539247
NEBV-S1W37-K10-LE37				10			539248
NEBV-S1W37-KM-2.5-LE10	Polyvinyl chloride (PVC)			2.5	10 x 0.34	7.7	543271
NEBV-S1W37-KM-5-LE10				5			543272
NEBV-S1W37-KM-10-LE10				10			543273
NEBV-S1W37-KM-2.5-LE27		Polyvinyl chloride (PVC)		2.5	27 x 0.34	11.5	543274
NEBV-S1W37-KM-5-LE27				5			543275
NEBV-S1W37-KM-10-LE27				10			543276
NEBV-S1W37-KM-2.5-LE37			Polyvinyl chloride (PVC)	2.5	37 x 0.34	13	543277
NEBV-S1W37-KM-5-LE37				5			543278
NEBV-S1W37-KM-10-LE37				10			543279

1) PUR for increased chemical resistance.

Electrical Components

Pin Allocation – Cage Clamp

Pin Allocation – Multi-pin Terminal Strip (Cage Clamp), 24 V DC and 110 V AC; Electrical Actuation Code T				
	Terminal	Coil/Address	Terminal	Coil/Address
<p>Each solenoid coil must be assigned to a specific terminal on the terminal strip in order for actuation of the valves to take place.</p>	1	0	17	16
	2	1	18	17
	3	2	19	18
	4	3	20	19
	5	4	21	20
	6	5	22	21
	7	6	23	22
	8	7	24	23
	9	8	25	24
	10	9	26	25
	11	10	27	26
	12	11	28	27
	13	12	29	28
	14	13	30	29
	15	14	31	30
	16	15	32	31
	<p>Note The drawing shows the view onto the multi-pin terminal strip (Cage Clamp).</p>	Conductor		
33		0 V	35	0 V
34		0 V	36	0 V

1) 0 V for positive switching control signals; connect 24 V for negative switching control signals; mixed operation is not permitted.

Electrical Components

Pin Allocation – Round Plugs

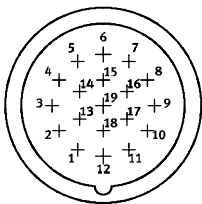
Pin Allocation – Round Plug Connector, 24 V DC; Electrical Actuation Code MP4				
	Address	Pin ¹⁾	Address	Pin ¹⁾
	0	15	8	17
	1	7	9	9
	2	5	10	2
	3	4	11	13
	4	16	12	11
	5	8	13	10
	6	3	14	1
	7	14	15	18

- 1) Pin 6: 0 V for positive switching control signals; connect 24 V for negative switching control signals; mixed operation is not permitted.
 Pin 12: Earth
 Pin 19: Unused

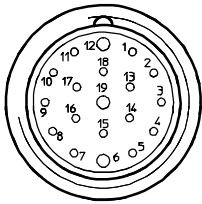
Pin Allocation – Round Plug Connector, 24 V DC; Electrical Actuation – CNOMO Assignment				
	Pin	Valve Position/Coil	Pin	Valve Position/Coil
	1	8/14	10	7/12
	2	6/14	11	7/14
	3	4/14	12	FE
	4	2/12	13	6/12
	5	2/14	14	4/12
	6	0 V ¹⁾	15	1/14
	7	1/12	16	3/14
	8	3/12	17	5/14
	9	5/12	18	8/12
			19	Unused

- 1) 0 V for positive switching control signals; connect 24 V for negative switching control signals; mixed operation is not permitted.

Electrical Components

Pin Allocation – M12x1, 4-pin Plug

Electrical Connection

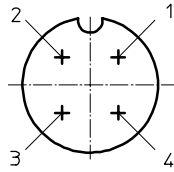
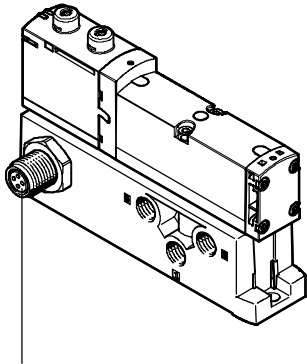

Pin allocation M12 on individual valve to ISO 20401

With positive logic:

- Pin1 – Not allocated
- Pin2 – +24 V DC for coil 12
- Pin3 – 0 V for coil 12 and 14
- Pin4 – +24 V DC for coil 14

With negative logic:

- Pin1 – Not allocated
- Pin2 – 0 V for coil 12
- Pin3 – +24 V DC for coil 12 and 14
- Pin4 – 0 V for coil 14

Connector Plug M12x1, 4-pin
to EN 61076-2-101

Electrical Accessories for Individual Valve

	Electrical Connection	Type of Mounting/Cable Length	Type	Part No.
Sensor Plug/Socket For Inputs/Outputs				
	Straight plug, 4-pin, screw terminal	Threaded connector M12	SEA-GS-7	18666
			SEA-GS-9	18778
			SEA-GS-11-DUO	18779
	Socket, angled, 4-pin, screw terminal	Union nut M12	SEA-M12-4WD-PG7	185498
	Straight plug, 4-pin, screw terminal	Threaded connector M12	SEA-4GS-7-2.5	192008
Plug Socket With Cable For Connecting Individual Valves or Sensors				
	Straight socket, 4-pin, M12	5 m	SIM-M12-4GD-5-PU	164259
	Angled socket, 4-pin, M12	5 m	SIM-M12-4WD-5-PU	164258

Installation and Operation

Mounting

Valve Terminal Assembly

Sturdy Terminal Attachment:

- Four through holes for wall mounting
- Additional mounting bracket
- DIN rail mounting

Wall Mounting

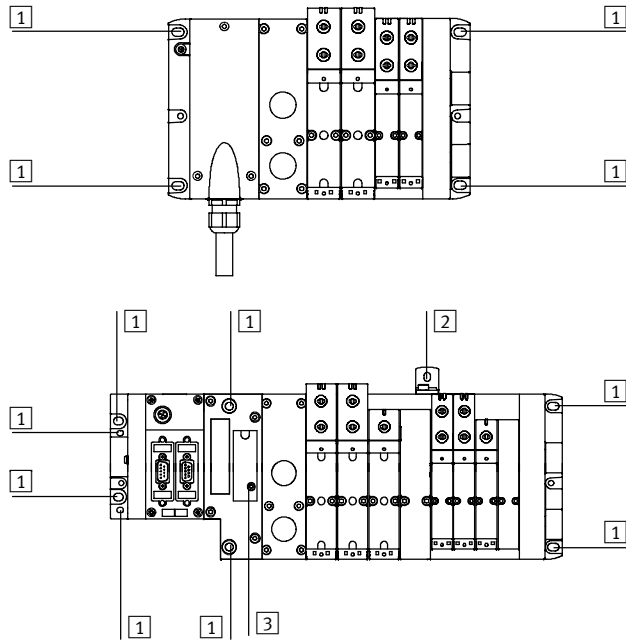

The VTSA valve terminal is screwed onto the mounting surface using M6 screws. The mounting holes are located at the following points:

- Multi-pin plug:
2 each at the multi-pin connection block and the right-hand end plate
- Fieldbus:
2 each at the left-hand (CPX) and right-hand (VTSA) end plate. The pneumatic interface additionally provides further mounting holes as well as optional mounting brackets.

The manifold subbase additionally provides the ability to add a bracket for wall mounting (type VTSA, Part No. 665983). The mounting brackets can be used with very long valve terminals (6 manifold subbases or more) to improve load capacity during vibrations or shocks.

- 1 Hole for M6 screw
- 2 Hole for M5 screw
- 3 Hole for DIN rail mounting

DIN Rail Mounting

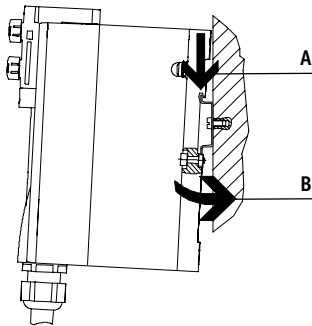

The VTSA valve terminal is attached to the DIN rail (see arrow A). It is then swivelled on the DIN rail and secured in place with the clamping component (see arrow B).

For DIN rail mounting of the valve terminal you will need the following VTSA mounting kit:

- With multi-pin plug:
CPA-BG-NRH
- With fieldbus:
CPX-CPA-BG-NRH

This permits mounting of the valve terminal on a DIN rail to EN 60715.

Individual Valve Assembly

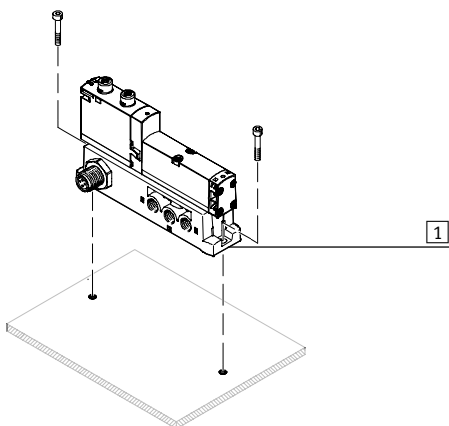

- 1 Vertical mounting holes

The individual subbase is designed for wall mounting or for integration into a system or machine. It is mounted vertically.

Installation and Operation

Pneumatic and Electrical Connection

Display and Operation

Each solenoid coil is allocated an LED which indicates its switching status.

- Indicator 12 shows the switching status of the pilot control for output 2
- Indicator 14 shows the switching status of the pilot control for output 4

Manual Override

Allows the valve to be switched when in the electrically nonactivated or de-energized status. Actuate the valve by pushing the manual override. The set switching status can be secured by turning the manual override.

Alternatives:

- A cover (accessory code N) can be fitted over the manual override to prevent it from being turned. The valve can then only be actuated by pressing it.

- A cover cap (accessory code V) can be fitted over the manual override to prevent it from being accidentally actuated.

Pneumatic Connection and Control Elements

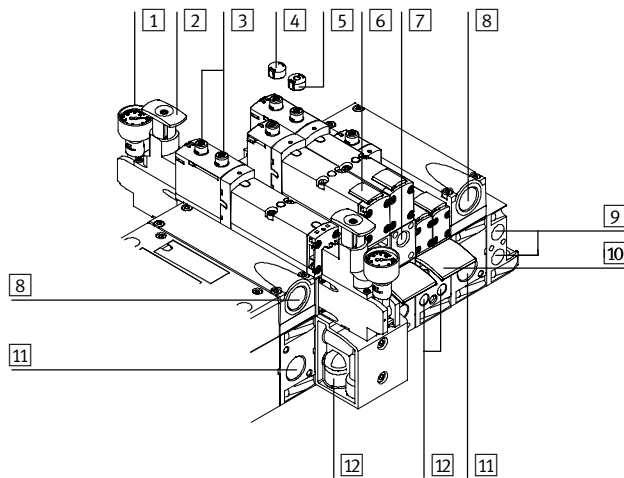

- 1 Pressure gauge (optional)
- 2 Adjusting knob of optional pressure regulating plate
- 3 Manual override (per pilot solenoid coil, pushing or pushing/detenting)
- 4 Optional cover cap for manual override (manual override non-functional)
- 5 Optional cover for manual override with non-detenting pushing function
- 6 Label for valve
- 7 Adjusting screw of optional throttle plate
- 8 Exhaust ports "valves" (3/5)
- 9 Ports 12 and 14 for ducted pilot exhaust and external pilot air supply
- 10 Label for subbase
- 11 Supply port 1 "operating pressure"
- 12 Working ports 2 and 4, per valve position

Notes

A manually activated valve (manual override) cannot be reset electrically. Conversely, an electrically activated valve cannot be reset using the mechanical manual override.

Pilot air must be present to activate the valve with the manual override.

Electrical Connection and Display Components

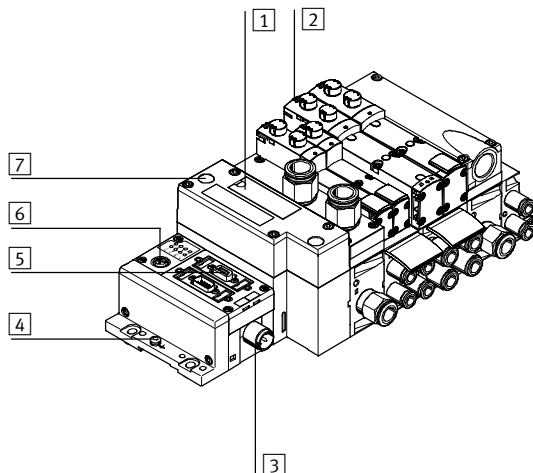

- 1 Inscription field and cover for DIN rail mounting
- 2 Yellow LEDs: Signal status display of pilot solenoid coils
- 3 Voltage supply connection
- 4 Earth terminal
- 5 Fieldbus connection (bus-specific)
- 6 Service interface for handheld unit, etc.
- 7 Red LED: Common error display of valves

Installation and Operation

Manual Override and Labeling

Manual Override (MO)

Manual Override with Automatic Return (non-detenting)

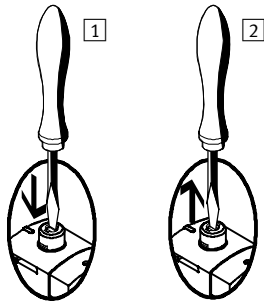

- 1 Press in the stem of the manual override using a pin or screwdriver. The valve is now in switching position.
- 2 Remove the screwdriver. Spring force pushes the stem of the manual override back. Valve returns to the initial position (not with double solenoid valve codes J and D).

Manual Override with Detent (locking)

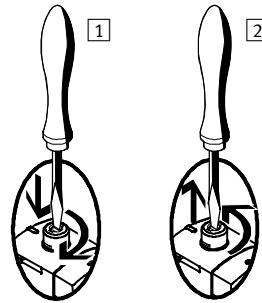

- 1 Press in the stem of the manual override using a screwdriver until the valve switches and then turn the stem clockwise by 90° until the stop is reached. The valve remains in switching position.
- 2 Turn the stem counterclockwise by 90° until the stop is reached and then remove the pin or screwdriver. Spring force pushes the stem of the manual override back. The valve returns to the initial position (not with double solenoid valve code J and D).

Labeling System

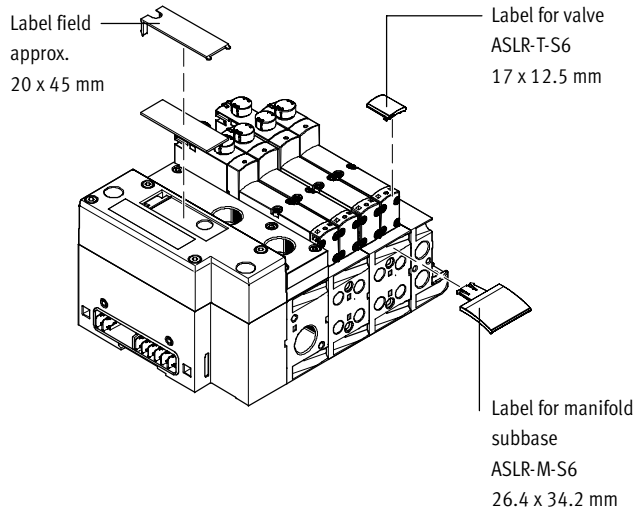

Label holders can be applied to the valves and subbases to identify them. These label holders can be ordered by entering the code B or T in the order code for accessories.

The following labels can be used as spares:

- Label for valve
Type ASLR-T-S6: Part No. 540888
- Label for subbases
Type ASLR-M-S6: Part No. 540889

Large labels can be applied to the pneumatic interface as an alternative or in addition to the smaller labels.

Technical Data

Pneumatic

FESTO

Flow Rate:

Width 18 mm (02): Valve flow up to 700 l/min

Width 26 mm (01): Valve flow up to 1,400 l/min

Valve Width:

02: 18 mm

01: 26 mm

Voltage:

24 V DC

110 V AC

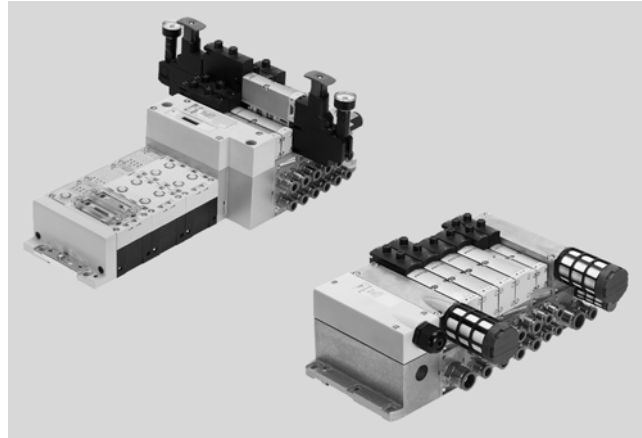

General Technical Data					
Width		18 mm (02)		26 mm (01)	
Design		Solenoid actuated piston spool valve			
Lubrication		Lubrication for life			
Type of mounting		Wall mounting			
		On DIN rail to EN 60715			
Assembly position		Any			
Manual override		Non-detenting, non-detenting/detenting, covered			
Width [mm]		18		26	
Pneumatic connections		18 mm (02)		26 mm (01)	
		ISO G Thread	NPT Thread	ISO G Thread	NPT Thread
Pneumatic connection		Via interlinking block			
Supply port	1	G $\frac{1}{2}$, QS-G $\frac{1}{2}$ -12, QS-G $\frac{1}{2}$ -16	$\frac{1}{2}$ NPT, QS- $\frac{1}{2}$ - $\frac{1}{2}$ -U, QS- $\frac{1}{2}$ - $\frac{5}{8}$ -U	G $\frac{1}{2}$, QS-G $\frac{1}{2}$ -12, QS-G $\frac{1}{2}$ -16	$\frac{1}{2}$ NPT, QS- $\frac{1}{2}$ - $\frac{1}{2}$ -U, QS- $\frac{1}{2}$ - $\frac{5}{8}$ -U
Exhaust port	3/5	G $\frac{1}{2}$, QS-G $\frac{1}{2}$ -12, QS-G $\frac{1}{2}$ -16	$\frac{1}{2}$ NPT, QS- $\frac{1}{2}$ - $\frac{1}{2}$ -U, QS- $\frac{1}{2}$ - $\frac{5}{8}$ -U	G $\frac{1}{2}$, QS-G $\frac{1}{2}$ -12, QS-G $\frac{1}{2}$ -16	$\frac{1}{2}$ NPT, QS- $\frac{1}{2}$ - $\frac{1}{2}$ -U, QS- $\frac{1}{2}$ - $\frac{5}{8}$ -U
Working ports	2/4	Depending on the connection type selected			
		■ G $\frac{1}{8}$ ■ QS-G $\frac{1}{8}$ -6 ■ QS-G $\frac{1}{8}$ -8	■ $\frac{1}{8}$ NPT ■ QS- $\frac{1}{8}$ - $\frac{1}{4}$ -U ■ QS- $\frac{1}{8}$ - $\frac{5}{16}$ -U	■ G $\frac{1}{4}$ ■ QS-G $\frac{1}{4}$ -8 ■ QS-G $\frac{1}{4}$ -10	■ $\frac{1}{4}$ NPT ■ QS- $\frac{1}{4}$ - $\frac{5}{16}$ -U ■ QS- $\frac{1}{4}$ - $\frac{3}{8}$ -U
Port for external pilot air supply	14	G $\frac{1}{4}$	$\frac{1}{4}$ NPT	G $\frac{1}{4}$	$\frac{1}{4}$ NPT
Pilot exhaust air port	12	G $\frac{1}{4}$	$\frac{1}{4}$ NPT	G $\frac{1}{4}$	$\frac{1}{4}$ NPT

Standard Nominal Flow Rate [l/min]																											
Width		18 mm (02)							26 mm (01)																		
Valve Function Order Code		M	O	J	D	N	K	H	B	G	E	P	Q	R	M	O	J	D	N	K	H	B	G	E	P	Q	R
Flow rate of valve		700		550		650 ¹⁾ 430 ²⁾		550		1,400		1,250		1,400 ¹⁾ 1,000 ²⁾		1,250											
Flow rate of valve on manifold subbase		550		400		450 ¹⁾ 300 ²⁾		400		1,100		900		1,000 ¹⁾ 700 ²⁾		900											
Flow rate of valve on individual subbase		600		500		550 ¹⁾ 360 ²⁾		500		1,200		1,100		1,200 ¹⁾ 850 ²⁾		1,100											

1) Switching position

2) Mid-position

Operating and Environmental Conditions			M	O	J	D	N	K	H	B	G	E	P	Q	R
Valve Function Order Code															
Operating medium			Filtered compressed air, lubricated or unlubricated, inert gases												
Grade of filtration			[μm]	40 (average pore size)											
Operating pressure			Pilot pressure	[bar]	3 ... 10										
			With internal pilot supply air	[bar]	3 ... 10										
			With external pilot supply air	[bar]	-0.9 ... +10			3 ... 10			-0.9 ... +10				
Ambient temperature			[$^{\circ}\text{C}$]	-5 ... +50											
Temperature of medium			[$^{\circ}\text{C}$]	-5 ... +50											
Storage temperature ¹⁾			[$^{\circ}\text{C}$]	-20 ... +40											
Relative air humidity			[%]	90											

1) Long-term storage

Pilot Pressure "p12/14" As a Function of Operating Pressure "p1"

For 3/2-way Valves

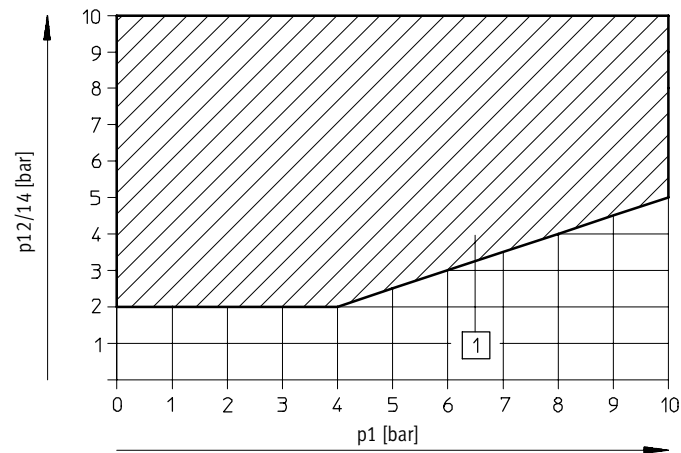

1) Operating range for valves with external pilot air supply

Valve Response Times [ms]

Valve Function Order Code		M	O	J	D	N	K	H	B	G	E	P	Q	R
18 mm (02)														
Response times	On	22	12	-	-	12	12	12	15	15	15	25	25	25
	Off	28	38	-	-	30	30	30	44	44	44	12	12	12
	Reversing	-	-	11	11	-	-	-	22	22	22	-	-	-
26 mm (01)														
Response times	On	25	20	-	-	20	20	20	22	22	22	32	32	32
	Off	45	65	-	-	38	38	38	65	65	65	30	30	30
	Reversing	-	-	18	18	-	-	-	33	33	33	-	-	-

Technical Data

Pneumatic

Materials		
	18 mm (02)	26 mm (01)
Manifold block	Die-cast aluminum	
Valve	Die-cast aluminum, reinforced polyamide	
Seals	Nitrile rubber, elastomer (support made of steel)	
Supply plate	Die-cast aluminum	
Right-hand end plate	Die-cast aluminum	
Left-hand pneumatic interface	Die-cast aluminum	
Throttle plate	Die-cast aluminum	
Pressure regulator plate	Die-cast aluminum, reinforced polyamide	
Multi-pin connection block	Die-cast aluminum	
Cover for the pneumatic interface and multi-pin plug connection	Wellamid, reinforced polyamide	

Product Weight		
Approx. Weights	[g]	
	18 mm (02)	26 mm (01)
Sub-D multi-pin interface module or terminal strip ¹⁾	550	
CPX Interface module ¹⁾	1,470	
Supply plate ²⁾		
■ Exhaust plate with 3 and 5 common	617	
■ Exhaust port cover with 3 and 5 separated	597	
Right-hand end plate ³⁾		
■ Axial	339	
■ Selector	281	
Manifold subbase ⁴⁾	447	634
90° connection plate ³⁾	170	230
Pressure regulator plate		
for port 1	702	429
for port 4 or 2	1,060	483
for ports 4/2	1,304	743
Throttle plate	228	320
Vertical supply plate ³⁾	140	191
Vertical isolating plate	209	273
Valves		
■ 5/3-way valve (code: B, G, E)	191	320
■ 5/2-way valve, single solenoid (code: M, O)	163	293
■ 5/2-way valve, double solenoid (code: J, D)	172	276
■ 2x 3/2-way valve (code: N, K, H, P, Q, R)	190	335
Blanking plate	34.4	73.3

1) With thin metal seal, printed circuit board.

2) With thin metal seal and electrical manifold module.

3) With screws.

4) With thin metal seal, electrical manifold module, label holder, and 4 screws.

Flow Rate q_{nN} As a Function of Output Pressure p_2 with Pressure Regulating Plates (P Regulator Block) for Port 1

Width: 18 mm (02)

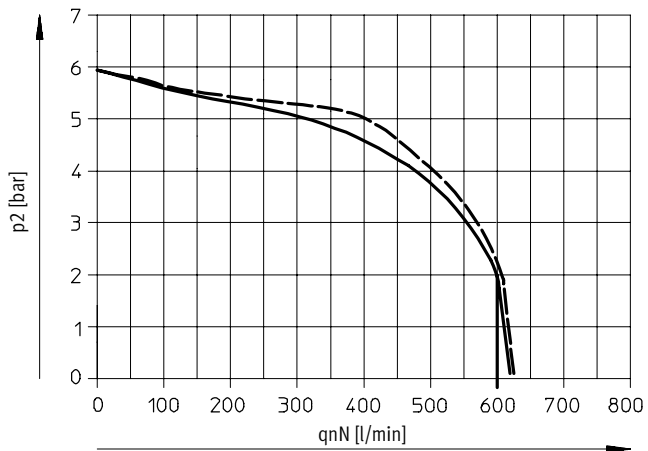

--- 6 bar
— 10 bar

Width: 26 mm (01)

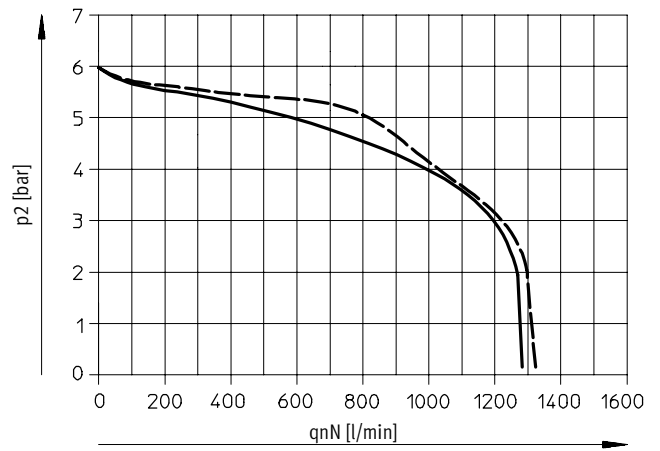

--- 6 bar
— 10 bar

Flow Rate q_{nN} As a Function of Output Pressure p_2 with Pressure Regulating Plates (A/B Regulator Blocks) for Port 2, 4 or Ports 4/2

Width: 18 mm (02)

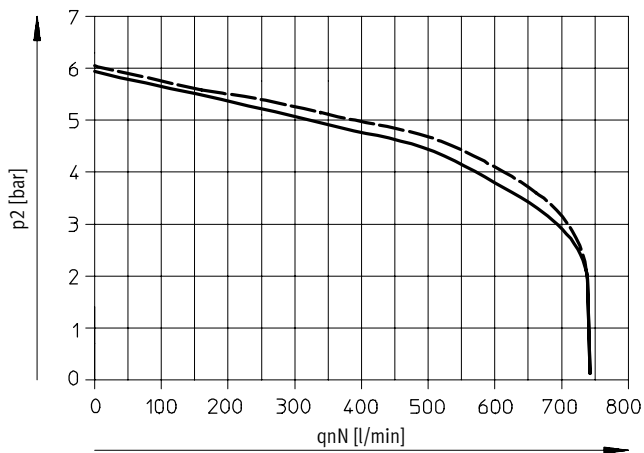

--- 6 bar
— 10 bar

Width: 26 mm (01)

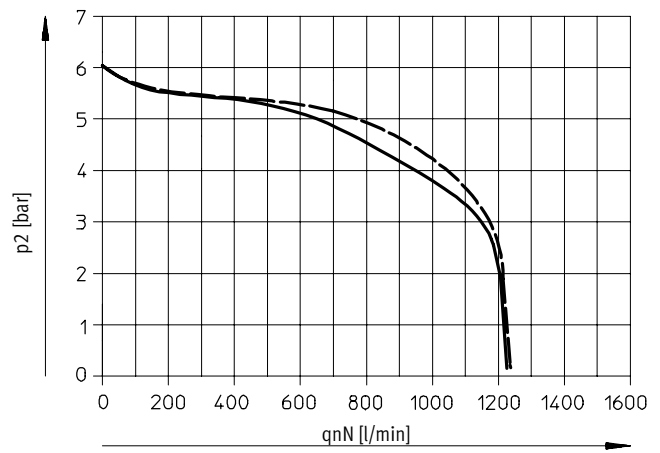

--- 6 bar
— 10 bar

Technical Data

Pneumatic

Flow Rate q_{nN} As a Function of Output Pressure p_2 with Pressure Regulating Plates (A/B Regulator Blocks, Rev.) for Ports 4/2, Reversible

Width: 18 mm (02)

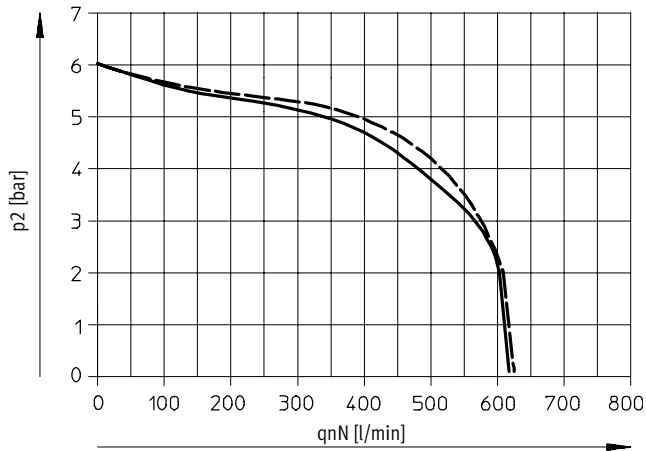

--- 6 bar
— 10 bar

Width: 26 mm (01)

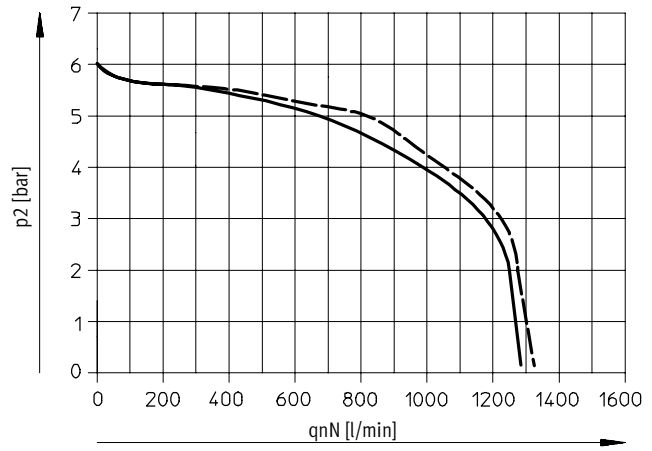

--- 6 bar
— 10 bar

Flow Rate As a Function of Flow Control

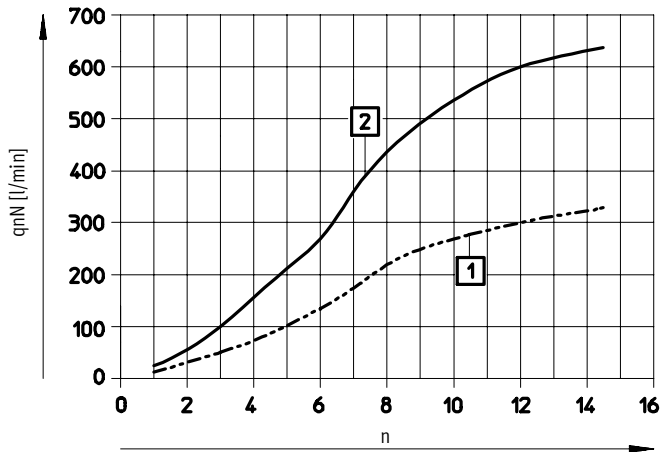

1 Width: 18 mm (02)
2 Width: 26 mm (01)

n = number of turns of adjustment screw

Technical Data

Electrical

FESTO

Electrical Data		
VTSA with CPX Terminal	18 mm (02)	26 mm (01)
Voltage Supply For Electronics/Sensors (Pin 1)		
Operating voltage	[V]	24 DC ±10%
Steady state current consumption at 24 V DC	[mA]	20
Load Voltage Supply for Valves (Pin 2)		
Operating voltage	[V]	24 DC ±10%
Diagnostic message on undervoltage V_{OFF} Load voltage outside function range	[V]	17.5 ... 16
Protection class to EN 60529	IP65 (for all types of signal transmission in assembled state)	
Power Consumption at 24 V DC		
2x 3/2-way valve	1.3 W	
5/2-way valve, 5/3-way valve	1.6 W	

Electrical Data		
VTSA with Multipin Connection	18 mm (02)	26 mm (01)
Load Voltage Supply for Valves		
Operating voltage	[V]	24 DC ±10% 110 AC ±10%
Protection class to EN 60529	IP65	
Power Consumption at 24 V DC		
2x 3/2-way valve	1.3 W	
5/2-way valve, 5/3-way valve	1.6 W	
Power Consumption at 110 V AC		
2x 3/2-way valve	1 VA	
5/2-way valve, 5/3-way valve	1.6 VA	

Data on Vibrations and Shock in Accordance with DIN/EC68		
	18 mm (02)	26 mm (01)
Vibration ¹⁾	Tested to DIN/IEC68 / EN 60068 Parts 2 ... 6 With horizontal DIN rail mounting: Severity level 1 With wall mounting: ²⁾	
Shock ¹⁾	Tested to DIN/IEC68 / EN a60068 Parts 2 ... 27 With horizontal DIN rail mounting: Severity level 1 With wall mounting: Severity level 1 ... ²⁾	
Continuous shock	Tested to DIN/IEC68 / EN 60068 Parts 2 ... 29 With wall and DIN rail mounting: Severity level 1	

- 1) See the CPX System Description for information on vibrations and shock for the CPX terminal.
 2) Valve terminal VTSA with CPX terminal and up to 5 manifold blocks without additional mountings: Severity level 2
 6 or more manifold blocks without additional mounting (wall bracket) after 2 to max. 4 manifold blocks: Severity level 2

Test Conditions			
Severity Level	Vibration	Shock	Continuous Shock
1	0.15 mm travel at 10 ... 58 Hz; 2 g acceleration at 58 ... 150 Hz	±15 g at 11 ms duration; 5 shocks per direction	±15 g at 6 ms duration; 1,000 shocks per direction
2	0.35 mm travel at 10 ... 60 Hz; 5 g acceleration at 60 ... 150 Hz	±30 g at 11 ms duration; 5 shocks per direction	—
Continuous shock resistance	To DIN/IEC 68/EN 60068, Parts 2-29: +/- 15 g at 6 ms, 1,000 cycles		

Individual Subbase with Clamped Terminal Connection, Width: 18 mm (02)

Download CAD data → www.festo.com/en/engineering

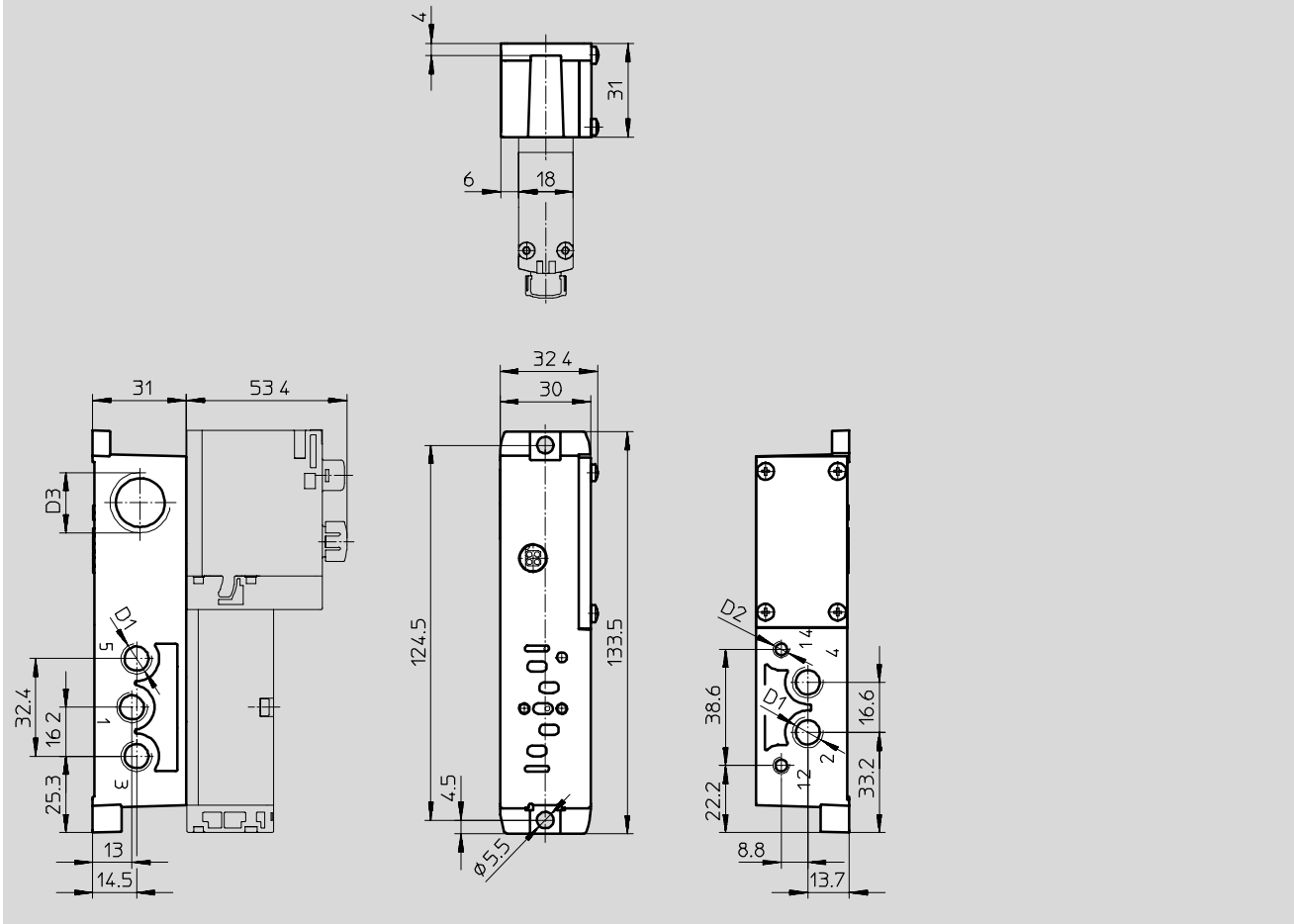

Type	D1	D2	D3
External Pilot Air Supply, Terminals			
VABS-S4-2S-G18-K2	G1/8	M5	M20x1.5
VABS-S4-2S-N18-K2	1/8NPT	10-32 UNF-2B	1/2NPT
Internal Pilot Air Supply, Terminals			
VABS-S4-2S-G18-B-K2	G1/8	M5	M20x1.5
VABS-S4-2S-N18-B-K2	1/8NPT	10-32 UNF-2B	1/2NPT

Technical Data

Dimensions

Individual Subbase with M12 Plug, Width: 26 mm (01)

Download CAD data → www.festo.com/en/engineering

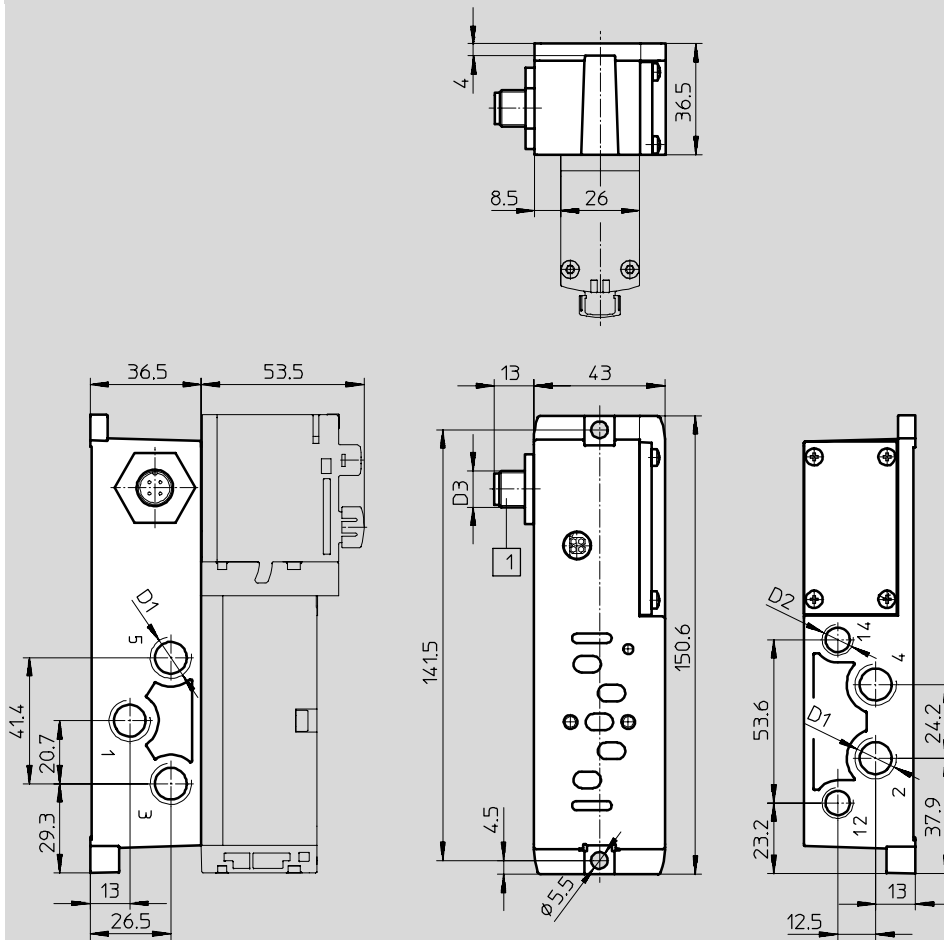

1 Plug to EN 61076-2-101

Type	D1	D2	D3
External Pilot Air Supply, M12 Plug			
VABS-S4-1S-G14-R3	G $\frac{1}{4}$	G $\frac{1}{8}$	M12
Internal Pilot Air Supply, M12 Plug			
VABS-S4-1S-G14-B-R3	G $\frac{1}{4}$	G $\frac{1}{8}$	M12

Individual Subbase with Clamped Terminal Connection, Width: 26 mm (01)

Download CAD data → www.festo.com/en/engineering

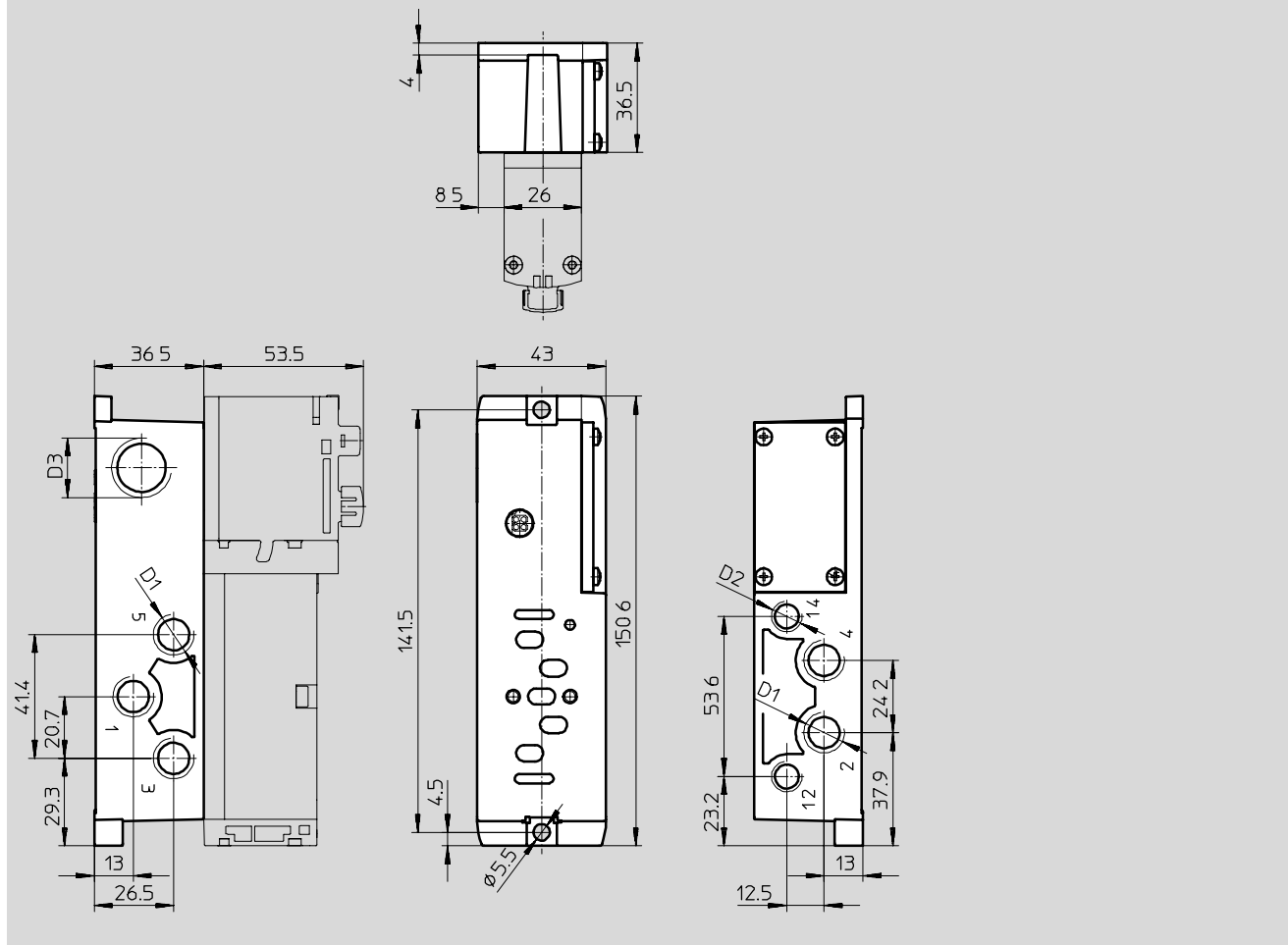

Type	D1	D2	D3
External Pilot Air Supply, Terminals			
VABS-S4-1S-G14-K2	G $\frac{1}{4}$	G $\frac{1}{8}$	M20x1.5
VABS-S4-1S-N14-K2	$\frac{1}{4}$ NPT	$\frac{1}{8}$ NPT	$\frac{1}{2}$ NPT
Internal Pilot Air Supply, Terminals			
VABS-S4-1S-G14-B-K2	G $\frac{1}{4}$	G $\frac{1}{8}$	M20x1.5
VABS-S4-1S-N14-B-K2	$\frac{1}{4}$ NPT	$\frac{1}{8}$ NPT	$\frac{1}{2}$ NPT

Valve Terminal with Multi-pin Plug Connection

Download CAD data → www.festo.com/en/engineering

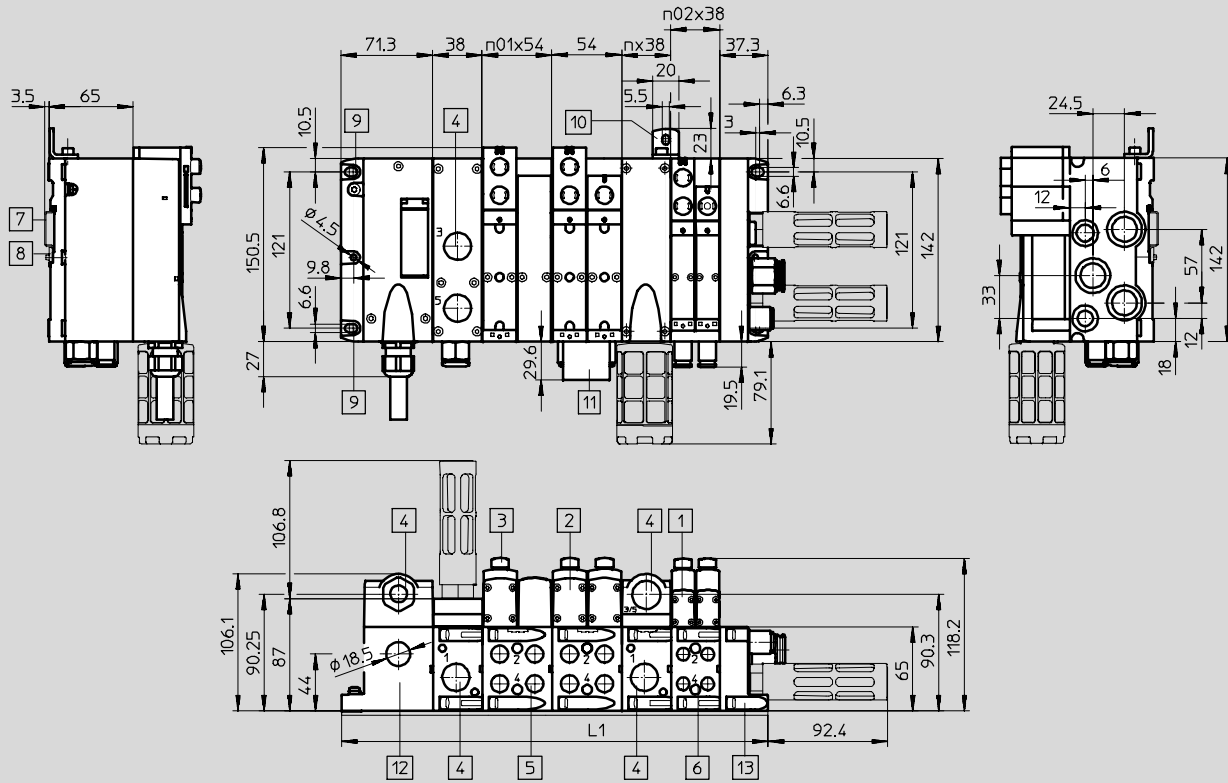

- | | | | |
|-----------------------------|---|--------------------------------|--|
| 1 Solenoid valve 18 mm (02) | 4 Threaded connection G $\frac{1}{2}$ / $\frac{1}{2}$ NPT | 10 Additional mounting bracket | n02 = Number of 18 mm manifold subbases (02) |
| 2 Solenoid valve 26 mm (01) | 5 Threaded connection G $\frac{1}{4}$ / $\frac{1}{4}$ NPT | 11 Label | n01 = Number of 26 mm manifold subbases (01) |
| 3 Cover cap/manual override | 6 Threaded connection G $\frac{3}{8}$ / $\frac{1}{8}$ NPT | 12 Multi-pin plug connection | n = Number of supply plates |
| 7 DIN rail | 8 DIN rail mounting | 13 End plate | |
| 8 DIN rail mounting | 9 Mounting hole | | |

Width	L1
18 mm (02)	$71.3 + n02 \times 38 + n \times 38 + 37.3$
26 mm (01)	$71.3 + n01 \times 54 + n \times 38 + 37.3$
Mixture of 18 mm (02) and 26 mm (01)	$71.3 + n02 \times 38 + n01 \times 54 + n \times 38 + 37.3$

Multi-pin Plug, Terminal Strip (Cage Clamp)

Download CAD data → www.festo.com/en/engineering

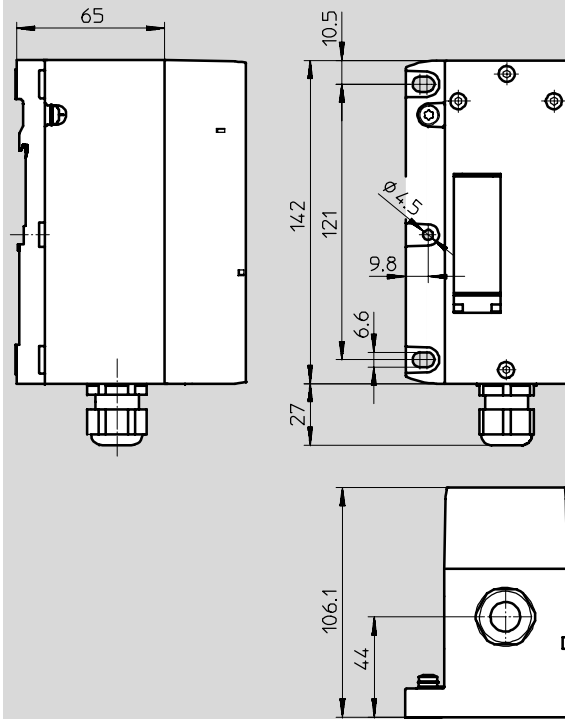

Multi-pin, Round Plug Connector

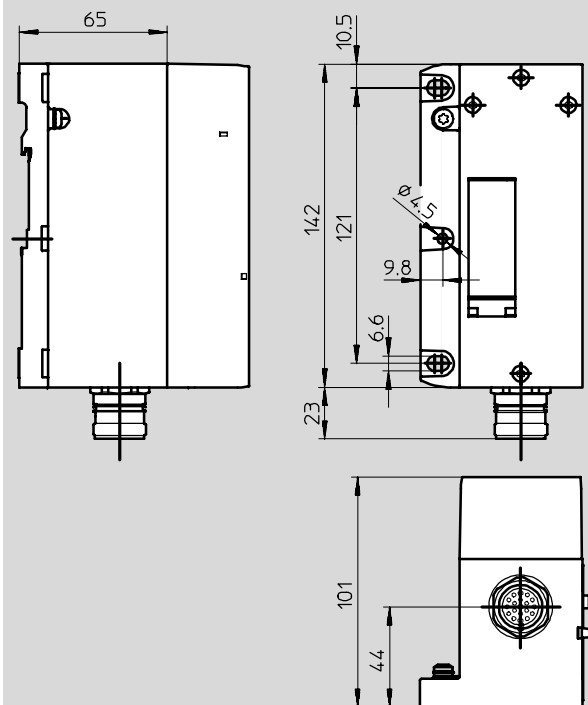

Valve Terminal with Fieldbus Connection

Download CAD data → www.festo.com/en/engineering

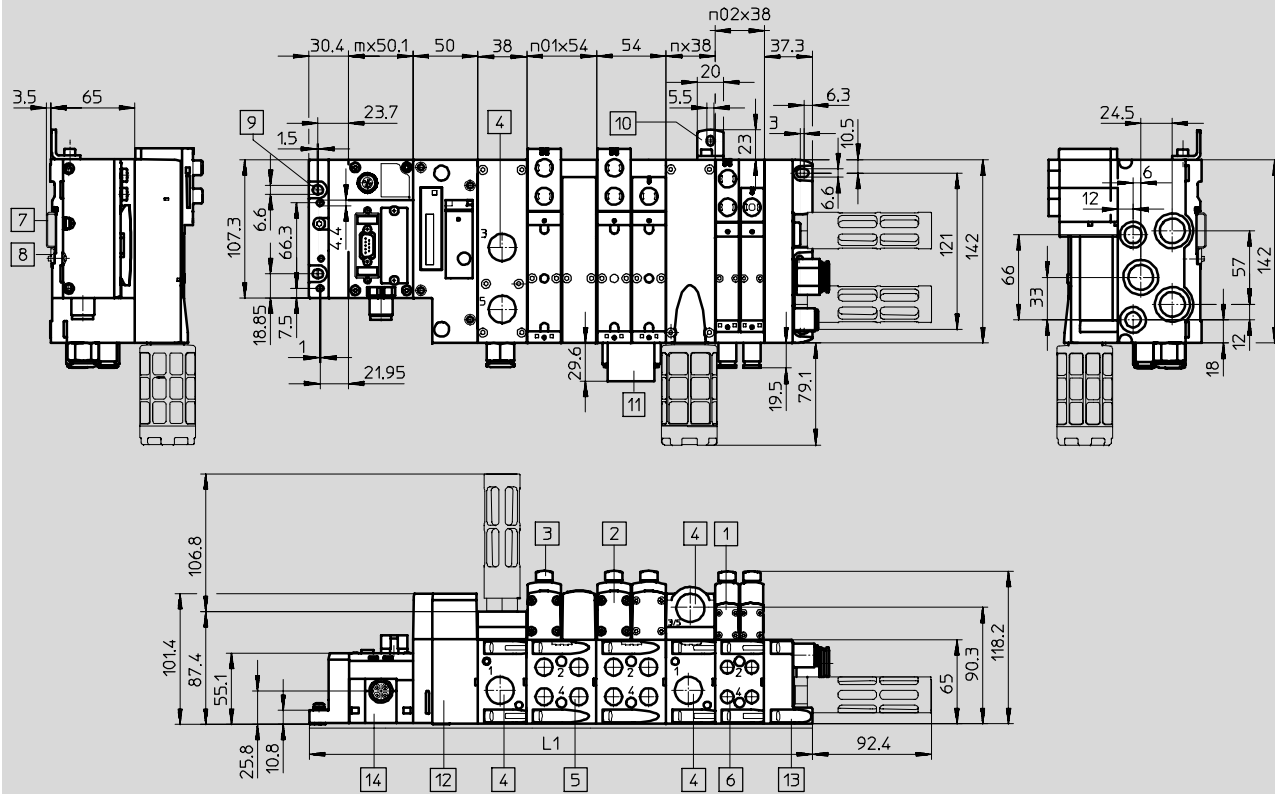

- | | | | |
|-----------------------------|---|--------------------------------|--|
| 1 Solenoid valve 18 mm (O2) | 4 Threaded connection G $\frac{1}{2}$ / $\frac{1}{2}$ NPT | 10 Additional mounting bracket | n02 = Number of 18 mm manifold subbases (O2) |
| 2 Solenoid valve 26 mm (O1) | 5 Threaded connection G $\frac{3}{4}$ / $\frac{1}{4}$ NPT | 11 Label | n01 = Number of 26 mm manifold subbases (O1) |
| 3 Cover cap/manual override | 6 Threaded connection G $\frac{1}{8}$ / $\frac{1}{8}$ NPT | 12 CPX Pneumatic interface | n = Number of supply plates (only with selector end plate) |
| | 7 DIN rail | 13 End plate | m = Number of CPX modules |
| | 8 DIN rail mounting | 14 CPX module/fieldbus node | |
| | 9 Mounting hole | | |

Width	L1
18 mm (O2)	$30.4 + m \times 50.1 + 50 + n02 \times 38 + n \times 38 + 37.3$
26 mm (O1)	$30.4 + m \times 50.1 + 50 + n01 \times 54 + n \times 38 + 37.3$
Mixture of 18 mm (O2) and 26 mm (O1)	$30.4 + m \times 50.1 + 50 + n02 \times 38 + n01 \times 54 + n \times 38 + 37.3$

Vertical Stacking Components

Download CAD data → www.festo.com/en/engineering

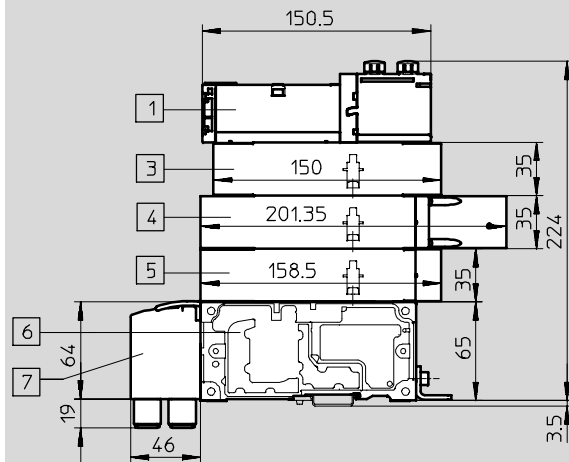

- 1 Solenoid valve
- 3 Throttle plate
- 5 Vertical supply plate
- 7 90° connection plate
- 4 Vertical isolating plate
- 6 Manifold subbase

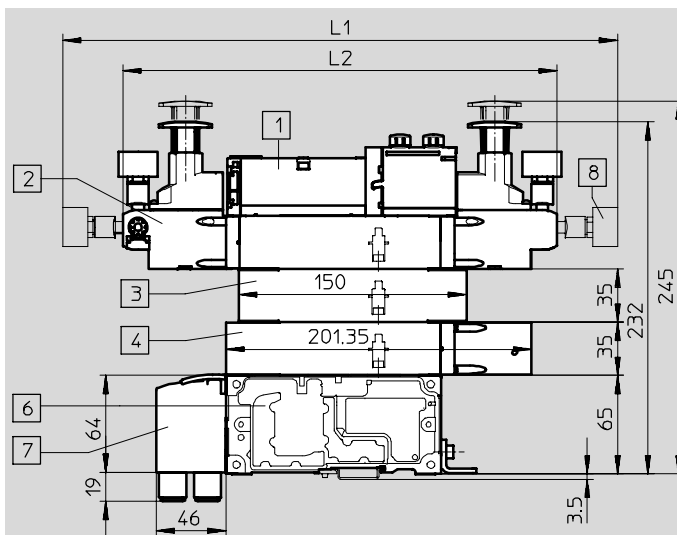

- 1 Solenoid valve
- 2 Pressure regulator plate
- 3 Throttle plate
- 4 Vertical isolating plate
- 5 Vertical supply plate
- 6 Manifold subbase
- 7 90° connection plate
- 8 Pressure gauge, position freely

Width	L1	L2
18 mm (02)	348.2	268.6
26 mm (01)	365.7	286.1

Technical Data

Dimensions

FESTO

Right-hand End Plate

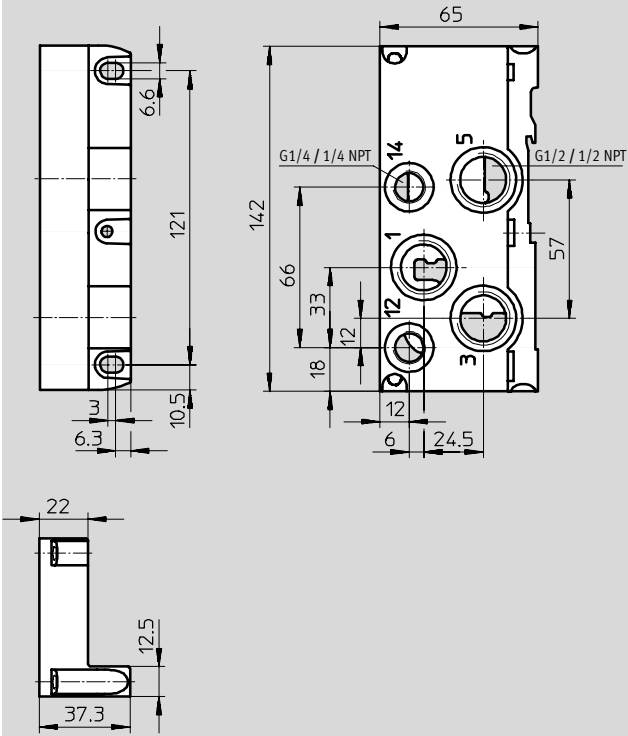

Selector End Plate

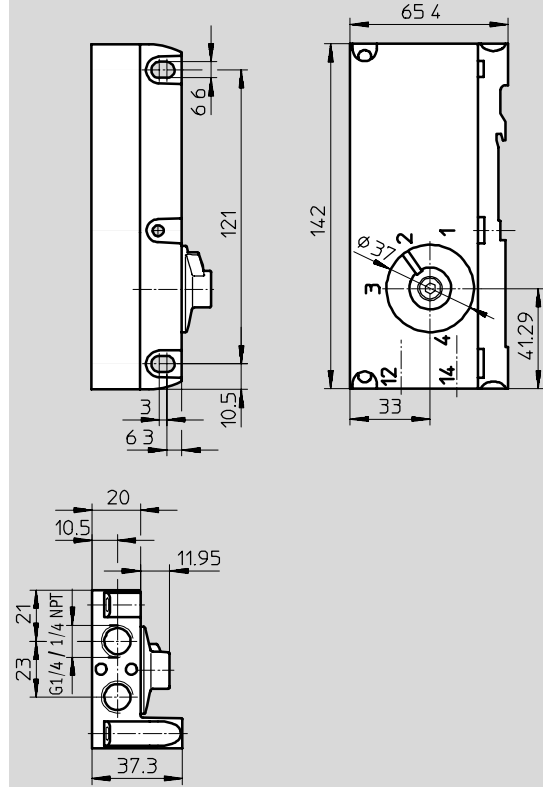

Ordering Data – ISO Thread

Multi-pin Connection, Electrical Section

M Mandatory Data				O Options		
Module No.	Valve terminal, electrical part	Electrical connection	Voltage	Connecting cable for multi-pin plug connection	User's manual	DIN rail mounting
539215	44E	T, MP1, MP4	P, Q	GA, GB, GC, GD, GE, GF, GG, GH, GI, GK, GL, GM, GN, GO, GP, GQ, GR, GS	E, D, F, I, S, V	H
Order Example						
539215	44E	-MP1	-P	+GE	-E	-7
1	2	3	4	5	6	7

Ordering Table			Conditions	Code	Enter Code	
M 1	Module No.	539215				
2	Valve terminal, electrical part	Valve terminal type 44, VTSA, electrical multi-pin plug connection/terminal box		44E	44E	
3	Electrical connection	Multi-pin plug, Cage Clamp	1	-T		
		Electrical multi-pin plug connection, Sub-D (37-pin)	1	-MP1		
		Electrical multi-pin plug connection, round plug connector (19-pin), M23	2	-MP4		
4	Voltage	24 V DC		-P		
		110 V AC	3	-Q		
O 5	Electrical accessories			+	+	
	Connecting cable for multi-pin plug connection is pre-assembled, and supplied loose	Polyurethane	Connecting cable for Sub-D, 2.5 m, 10-wire, 8 solenoid coils		GA	
			Connecting cable for Sub-D, 5 m, 10-wire, 8 solenoid coils		GB	
			Connecting cable for Sub-D, 10 m, 10-wire, 8 solenoid coils		GC	
			Connecting cable for Sub-D, 2.5 m, 26-wire, 22 solenoid coils		GD	
			Connecting cable for Sub-D, 5 m, 26-wire, 22 solenoid coils		GE	
			Connecting cable for Sub-D, 10 m, 26-wire, 22 solenoid coils		GF	
			Connecting cable for Sub-D, 2.5 m, 37-wire, 32 solenoid coils		GG	
			Connecting cable for Sub-D, 5 m, 37-wire, 32 solenoid coils		GH	
			Connecting cable for Sub-D, 10 m, 37-wire, 32 solenoid coils		GI	
		Polyvinyl chloride	Connecting cable for Sub-D, 2.5 m, 10-wire, 8 solenoid coils		GK	
			Connecting cable for Sub-D, 5 m, 10-wire, 8 solenoid coils		GL	
			Connecting cable for Sub-D, 10 m, 10-wire, 8 solenoid coils		GM	
			Connecting cable for Sub-D, 2.5 m, 27-wire, 22 solenoid coils		GN	
			Connecting cable for Sub-D, 5 m, 27-wire, 22 solenoid coils		GO	
			Connecting cable for Sub-D, 10 m, 27-wire, 22 solenoid coils		GP	
			Connecting cable for Sub-D, 2.5 m, 37-wire, 32 solenoid coils		GQ	
			Connecting cable for Sub-D, 5 m, 37-wire, 32 solenoid coils		GR	
			Connecting cable for Sub-D, 10 m, 37-wire, 32 solenoid coils		GS	
6	User's manual	English		-E		
		German		-D		
		French		-F		
		Italian		-I		
		Spanish		-S		
		Swedish		-V		
7	DIN rail mounting	1		-H		

1 Max. 32 addresses can be actuated.

3 Only with electrical actuator T (multi-pin plug, Cage Clamp).

2 Max. 16 addresses can be actuated.

Transfer Order Code

539215	44E	-		-		+		-		-	
1	2		3		4		5		6		7

Ordering Data – ISO Thread

Multi-pin Connection, Pneumatic Section

M Mandatory Data				O Options					
Module No.	Valve terminal, pneumatic part	Manual override	Right-hand end plate	Port design for supply plates	Pneumatic valve terminal supply	Design of all pneumatic connections	Outgoing direction of all working lines	Left-hand supply plate	Reverse operation
539215	44P	N, R, V	V, X, Y, U, Z, W	K, L	S, V	M, N, G	P, O	X	Z
Order Example									
539215	44P	R	V	K	S	M	P	X	Z
1	2	3	4	5	6	7	8	9	10

Ordering Table					
Width	18 mm (02)	26 mm (01)	Conditions	Code	Enter Code
M 1	Module No.	539215	539215		
2	Valve terminal, pneumatic part	Valve terminal type 44, VTSA, modular subbase valves to ISO 15407-2		44P	44P
3	Manual override	Non-detenting		-N	
		Non-detenting/detenting		-R	
		Covered		-V	
4	Right-hand end plate	Right-hand end plate, with supply air/exhaust air, internal pilot air supply		-V	
		Right-hand end plate with supply air/exhaust air, external pilot air supply		-X	
		Selector end plate, internal pilot air supply		1 -Y	
		Selector end plate, internal pilot air supply, ducted exhaust air		1 -U	
		Selector end plate, external pilot air supply		1 -Z	
		Selector end plate, external pilot air supply, ducted exhaust air		1 -W	
O 5	Port design for supply plates	Normal operation: Supply port 1, exhaust port 3/5 separated		2 -K	
		Reverse operation: Exhaust port 1, supply port 3/5 separated			
		Normal operation: Supply port 1, exhaust port 3/5 common		2 -L	
		Reverse operation: Exhaust port 1, supply port 3/5 common			
6	Pneumatic valve terminal supply (standard: threaded connection)	Silencer and QS push-in fittings		S	
		QS push-in fittings		V	
7	Design of all pneumatic connections	QS push-in fittings, large		3 M	
		QS push-in fittings, small		3 N	
		QS push-in fittings, large and small mixed		3 G	
8	Outgoing direction of all working lines (standard outlet at front)	90° connection plate, outlet at bottom		P	
		90° connection plate, outlet at top		O	
9	Left-hand supply plate	Left-hand supply plate in front of manifold subbase 00		X	
↓ 10	Reverse operation	Reverse operation as of valve position 00		4 Z	

- 1 At least one left-hand supply plate (9) X or one compressed air supply/duct separation (12) U, SU, TU, RU, USU, UTU or URU must be selected.
- 2 Must be selected if left-hand supply plate (9) X or one compressed air supply/duct separation (12) (S, T, R, U, SU, US, TU, UT, RU, UR, USU, UTU, URU) was selected.
- 3 Must be selected if pneumatic valve terminal supply (6) S or V was selected. Connection sizes of the pneumatic connections → See table on Page 68.
- 4 A reversible pressure zone cannot be terminated with a right-hand end plate (4) V, Y, U (internal pilot air supply).

Transfer Order Code

539215	44P	-		-		-				
1	2	3	4	5	6	7	8	9	10	

Ordering Data – ISO Thread

Multi-pin Connection, Pneumatic Section

→ **0** Options →

Pneumatic Manifold Subbases 00 ... 15

11 Type of interlinking block: A, B, E, F, AK, BK, EK, FK
12 Compressed air supply/duct separation: S, T, R, U, SU, US, TU, UT, RU, UR, USU, UTU, URU
13 Reverse operation: Z

Module Position

00	01	02	03	04	05	06	07	08	09	10	11	12	13	14	15
A	B	B	B	S	B										

11 + 12 + 13

Ordering Table							
Width			18 mm (ISO 02)	26 mm (ISO 01)	Conditions	Code	Enter Code
↓	11	Pneumatic manifold subbases			5	-	-
0	Type of interlinking block 00 ... 15	Manifold subbase	2 valve positions, 4 addresses	-		A	Enter the equipment selected in the order code
-			2 valve positions, 4 addresses		B		
			2 valve positions, 2 addresses	-	6	E	
-			2 valve positions, 2 addresses		6	F	
		Manifold subbase with QS push-in fittings, small	2 valve positions, 4 addresses	-	7	AK	
-			2 valve positions, 4 addresses		7	BK	
			2 valve positions, 2 addresses	-	8	EK	
-			2 valve positions, 2 addresses		8	FK	
	12 Compressed air supply/duct separation 00... 15	Duct separation 1, 3, 5		9 10	S		
		Duct separation 1		9 10	T		
		Duct separation 3, 5		9 10	R		
		Supply plate			U		
		Supply plate with duct separation 1, 3, 5 at left		9	SU		
		Supply plate with duct separation 1, 3, 5 at right		9	US		
		Supply plate with duct separation 1 at left		9	TU		
		Supply plate with duct separation 1 at right		9	UT		
		Supply plate with duct separation 3, 5 at left		9	RU		
		Supply plate with duct separation 3, 5 at right		9	UR		
		2 supply plates with duct separation 1, 3, 5 in center			USU		
		2 supply plates with duct separation 1 in center			UTU		
		2 supply plates with duct separation 3, 5 in center			URU		
↓	13	Reverse operation 00 ... 15	Subsequent valve positions permitted for reverse operation		11	Z	

- | | |
|--|--|
| 5 Manifold subbases must be equipped throughout without any gaps. | 9 No pressure-free zones may be created. |
| 6 Only with valves (14) M, O and L. | 10 Cannot be selected on last manifold subbase. |
| 7 Not with design of all pneumatic connections (7) M or N. | 11 Only with compressed air supply/duct separation (12) S, SU, US or USU. |
| 8 Not with design of all pneumatic connections (7) M or N.
Only with valves (14) M, O and L. | A reversible pressure zone cannot be terminated with a right-hand end plate (4) V, X, U. |

Transfer Order Code

00	01	02	03	04	05	06	07	08	09	10	11	12	13	14	15

11 + 12 + 13

Ordering Data – ISO Thread

Multi-pin Connection, Pneumatic Section

→ 0 Options →

Pneumatic Valve Positions 00 ... 31

- 14 Valve position 00 ... 31: M, O, J, D, N, K, H, B, G, E, P, Q, R, L
- 15 Pressure regulator for position 00 ... 31: ZA, ZB, ZC, ZD, ZE, ZF, ZG, ZH, ZI, ZJ
- 16 Pressure indicator for position 00 ... 31: T, U
- 17 Flow control valve position 00 ... 31: X
- 18 Pressure indicator for position 00 ... 31: ZT
- 19 Vertical supply plate for position 00 ... 31: ZU

Valve Position

00	01	02	03	04	05	06	07	08	09	10	11	12	13	14	15	16	17	18	19	20	...	30	31
M	M	M	O	O	O	J	J	E	E												...		

14 + 15 + 16 + 17 + 18 + 19

Ordering Table

Width	18 mm (ISO 02)	26 mm (ISO 01)	Conditions	Code	Enter Code
14	Pneumatic valve positions 00 ... 31			-	-
0	Valve position	5/2-way valve, single solenoid with pneumatic spring return		M	Enter equipment selection for valve positions in order code
		5/2-way valve, single solenoid with mechanical spring return		O	
		5/2-way valve, double solenoid		J	
		5/2-way valve, double solenoid with dominant signal		D	
		2x 3/2-way valve, normally open	12	N	
		2x 3/2-way valve, normally closed	12	K	
		2x 3/2-way valve, 1x normally closed, 1x normally open	12	H	
		5/3-way valve, mid-position pressurized		B	
		5/3-way valve, mid-position closed		G	
		5/3-way valve, mid-position exhausted		E	
		2x 3/2-way valve, normally open, reverse operation	13	P	
		2x 3/2-way valve, normally closed, reverse operation	13	Q	
		2x 3/2-way valve, 1x normally closed, 1x normally open, reverse operation	13	R	
		Spare position		L	
15	Pressure regulator	Input pressure 10 bar	Pressure regulator for port 1		ZA
			Pressure regulator for port 4		ZB
			Pressure regulator for port 2		ZC
			Pressure regulator for port 4/2		ZD
			Pressure regulator for port 4/2, reversible	14	ZE
	Input pressure 6 bar	Pressure regulator for port 1		ZF	
		Pressure regulator for port 4		ZG	
		Pressure regulator for port 2		ZH	
		Pressure regulator for port 4/2		ZI	
		Pressure regulator for port 4/2, reversible	14	ZJ	
16	Pressure indicator	Pressure gauge, 10 bar	15	T	
		Pressure gauge, 6 bar	16	U	
17	Flow control valve	Flow control valve	17	X	
18	Vertical isolating plate	Pressure separator plate on valve assembly		ZT	
19	Vertical supply plate	Compressed air supply on valve	17	ZU	

12 Not permissible in zones with exhaust air in duct 1 and compressed air in duct 3, 5.

13 Only permissible in zones with reverse operation.

14 Not with 2x 3/2-way valves (14) N, K, H.

15 Only with pressure regulator (15) ZA, ZB, ZC, ZD, ZE.

16 Only with pressure regulator (15) ZF, ZG, ZH, ZI, ZJ.

17 Not with valves with reverse operation (14) P, Q, R.

Transfer Order Code

00	01	02	03	04	05	06	07	08	09	10	11	12	13	14	15	16	17	18	19	20	...	30	31
																					...		

14 + 15 + 16 + 17 + 18 + 19

Ordering Data – ISO Thread

Multi-pin Connection, Pneumatic Section

→ **0** Options

Pneumatic Accessories

U, ...B, ...T, ...N, ...V

+ **2N**
20

Ordering Table					
Width	18 mm (ISO 02)	26 mm (ISO 01)	Conditions	Code	Enter Code
▼ 20	Pneumatic accessories			+	+
0	Mounting bracket	Ready-mounted	18	U	
	Label holder for valves	1 ... 99		...B	
	Label holder for manifold subbases	1 ... 99		...T	
	Cover for manual override, non-detenting, pack of 10	1 ... 9		...N	
	Cover for manual override, covered, pack of 10	1 ... 9		...V	

18 Can only be selected if there are more than 9 valve positions.

+
20

Ordering Data – ISO Thread

CPX Fieldbus Connection, Pneumatic Section

M Mandatory Data				O Options					
Module No.	Valve terminal, pneumatic part	Manual override	Right-hand end plate	Port design for supply plates	Pneumatic valve terminal supply	Design of all pneumatic connections	Outgoing direction of all working lines	Left-hand supply plate	Reverse operation
539217	44P	N, R, V	V, X, Y, U, Z, W	K, L	S, V	M, N, G	P, O	X	Z
Order Example									
539217	44P	R	V	K	S	M	P	X	Z
1	2	3	4	5	6	7	8	9	10

Ordering Table						
Width		18 mm (02)	26 mm (01)	Conditions	Code	Enter Code
M 1	Module No.	539217	539217			
2	Valve terminal, pneumatic part	Valve terminal type 44, VTSA, modular subbase valves to ISO 15407-2			44P	44P
3	Manual override	Non-detenting			-N	
		Non-detenting/detenting			-R	
		Covered			-V	
4	Right-hand end plate	Right-hand end plate, with supply air/exhaust air, internal pilot air supply			-V	
		Right-hand end plate with supply air/exhaust air, external pilot air supply			-X	
		Selector end plate, internal pilot air supply		1	-Y	
		Selector end plate, internal pilot air supply, ducted exhaust air		1	-U	
		Selector end plate, external pilot air supply		1	-Z	
		Selector end plate, external pilot air supply, ducted exhaust air		1	-W	
O 5	Port design for supply plates	Normal operation: Supply port 1, exhaust port 3/5 separated		2	-K	
		Reverse operation: Exhaust port 1, supply port 3/5 separated				
		Normal operation: Supply port 1, exhaust port 3/5 common		2	-L	
		Reverse operation: Exhaust port 1, supply port 3/5 common				
6	Pneumatic valve terminal supply (standard: threaded connection)	Silencer and QS push-in fittings			S	
		QS push-in fittings			V	
7	Design of all pneumatic connections	QS push-in fittings, large		3	M	
		QS push-in fittings, small		3	N	
		QS push-in fittings, large and small mixed		3	G	
8	Outgoing direction of all working lines (standard outlet at front)	90° connection plate, outlet at bottom			P	
		90° connection plate, outlet at top			O	
9	Left-hand supply plate	Left-hand supply plate in front of manifold subbase 00			X	
O 10	Reverse operation	Reverse operation as of valve position 00		4	Z	

- 1 At least one left-hand supply plate (9) X or one compressed air supply/duct separation (12) U, SU, TU, RU, USU, UTU or URU must be selected.
- 2 Must be selected if left-hand supply plate (9) X or one compressed air supply/duct separation (12) (S, T, R, U, SU, US, TU, UT, RU, UR, USU, UTU, URU) was selected.
- 3 Must be selected if pneumatic valve terminal supply (6) S or V was selected. Connection sizes of the pneumatic connections → See table on Page 68.
- 4 A reversible pressure zone cannot be terminated with a right-hand end plate (4) V, Y, U (internal pilot air supply).

Transfer Order Code

539217	44P	-		-		-				
1	2	3	4	5	6	7	8	9	10	

Ordering Data – ISO Thread

CPX Fieldbus Connection, Pneumatic Section

→ 0 Options →

Pneumatic Manifold Subbases 00 ... 15

11 Type of interlinking block: A, B, E, F, AK, BK, EK, FK
 12 Compressed air supply/duct separation: S, T, R, U, SU, US, TU, UT, RU, UR, USU, UTU, URU
 13 Reverse operation: Z

Module Position

00	01	02	03	04	05	06	07	08	09	10	11	12	13	14	15
A	B	B	B	S	B										

11 + 12 + 13

Ordering Table							
Width		18 mm (ISO 02)	26 mm (ISO 01)	Conditions	Code	Enter Code	
↓	11	Pneumatic manifold subbases			5	-	-
0	Type of interlinking block 00 ... 15	Manifold subbase	2 valve positions, 4 addresses	-		A	Enter the equipment selected in the order code
			-	2 valve positions, 4 addresses		B	
			2 valve positions, 2 addresses	-	6	E	
			-	2 valve positions, 2 addresses	6	F	
		Manifold subbase with QS push-in fittings, small	2 valve positions, 4 addresses	-	7	AK	
			-	2 valve positions, 4 addresses	7	BK	
			2 valve positions, 2 addresses	-	8	EK	
			-	2 valve positions, 2 addresses	8	FK	
	12 Compressed air supply/duct separation 00... 15	Duct separation 1, 3, 5		9 10	S		
		Duct separation 1		9 10	T		
		Duct separation 3, 5		9 10	R		
		Supply plate			U		
		Supply plate with duct separation 1, 3, 5 at left		9	SU		
		Supply plate with duct separation 1, 3, 5 at right		9	US		
		Supply plate with duct separation 1 at left		9	TU		
		Supply plate with duct separation 1 at right		9	UT		
		Supply plate with duct separation 3, 5 at left		9	RU		
		Supply plate with duct separation 3, 5 at right		9	UR		
		2 supply plates with duct separation 1, 3, 5 in center			USU		
		2 supply plates with duct separation 1 in center			UTU		
		2 supply plates with duct separation 3, 5 in center			URU		
↓	13	Reverse operation 00 ... 15	Subsequent valve positions permitted for reverse operation		11	Z	

- 5 Manifold subbases must be equipped throughout without any gaps.
- 6 Only with valves (14) M, O and L.
- 7 Not with design of all pneumatic connections (7) M or N.
- 8 Not with design of all pneumatic connections (7) M or N. Only with valves (14) M, O and L.

- 9 No pressure-free zones may be created.
- 10 Cannot be selected on last manifold subbase.
- 11 Only with compressed air supply/duct separation (12) S, SU, US or USU. A reversible pressure zone cannot be terminated with a right-hand end plate (4) V, Y, U.

Transfer Order Code

00	01	02	03	04	05	06	07	08	09	10	11	12	13	14	15

11 + 12 + 13

Ordering Data – ISO Thread

CPX Fieldbus Connection, Pneumatic Section



Options

Pneumatic Valve Positions 00 ... 31

- 14 Valve position 00 ... 31: M, O, J, D, N, K, H, B, G, E, P, Q, R, L
- 15 Pressure regulator for position 00 ... 31: ZA, ZB, ZC, ZD, ZE, ZF, ZG, ZH, ZI, ZJ
- 16 Pressure indicator for position 00 ... 31: T, U
- 17 Flow control valve position 00 ... 31: X
- 18 Pressure indicator for position 00 ... 31: ZT
- 19 Vertical supply plate for position 00 ... 31: ZU

Valve Position

00 01 02 03 04 05 06 07 08 09 10 11 12 13 14 15 16 17 18 19 20 ... 30 31

- M M M O O O J J E E ...

14 + 15 + 16 + 17 + 18 + 19

Ordering Table							
Width	18 mm (ISO 02)		26 mm (ISO 01)		Conditions	Code	Enter Code
14	Pneumatic valve positions 00 ... 31					-	-
0	Valve position	5/2-way valve, single solenoid with pneumatic spring return			M	equipment selection for valve positions in order code	
		5/2-way valve, single solenoid with mechanical spring return			O		
		5/2-way valve, double solenoid			J		
		5/2-way valve, double solenoid with dominant signal			D		
		2x 3/2-way valve, normally open		12	N		
		2x 3/2-way valve, normally closed		12	K		
		2x 3/2-way valve, 1x normally closed, 1x normally open		12	H		
		5/3-way valve, mid-position pressurized			B		
		5/3-way valve, mid-position closed			G		
		5/3-way valve, mid-position exhausted			E		
		2x 3/2-way valve, normally open, reverse operation		13	P		
		2x 3/2-way valve, normally closed, reverse operation		13	Q		
		2x 3/2-way valve, 1x normally closed, 1x normally open, reverse operation		13	R		
		Vacant position			L		
15	Pressure regulator	Input pressure 10 bar	Pressure regulator for port 1			ZA	
			Pressure regulator for port 4			ZB	
			Pressure regulator for port 2			ZC	
			Pressure regulator for port 4/2			ZD	
			Pressure regulator for port 4/2, reversible		14	ZE	
		Input pressure 6 bar	Pressure regulator for port 1			ZF	
			Pressure regulator for port 4			ZG	
			Pressure regulator for port 2			ZH	
			Pressure regulator for port 4/2			ZI	
			Pressure regulator for port 4/2, reversible		14	ZJ	
16	Pressure indicator	Pressure gauge, 10 bar		15	T		
		Pressure gauge, 6 bar		16	U		
17	Flow control valve	Flow control valve		17	X		
18	Vertical isolating plate	Pressure separator plate on valve assembly			ZT		
19	Vertical supply plate	Compressed air supply on valve		17	ZU		

12 Not permissible in zones with exhaust air in duct 1 and compressed air in duct 3, 5.

13 Only permissible in zones with reverse operation.

14 Not with 2x 3/2-way valves (14) N, K, H.

15 Only with pressure regulator (15) ZA, ZB, ZC, ZD, ZE.

16 Only with pressure regulator (15) ZF, ZG, ZH, ZI, ZJ.

17 Not with valves with reverse operation (14) P, Q, R.

Transfer Order Code

00 01 02 03 04 05 06 07 08 09 10 11 12 13 14 15 16 17 18 19 20 ... 30 31

- ...

14 + 15 + 16 + 17 + 18 + 19

Ordering Data – ISO Thread

CPX Fieldbus Connection, Pneumatic Section

→ **0** Options

Pneumatic Accessories

U, ...B, ...T, ...N, ...V

+ **2N**

20

Ordering Table					
Width	18 mm (ISO 02)	26 mm (ISO 01)	Conditions	Code	Enter Code
↓ 20	Pneumatic accessories			+	+
0	Mounting bracket	Ready-mounted	18	U	
	Label holder for valves	1 ... 99		...B	
	Label holder for manifold subbases	1 ... 99		...T	
	Cover for manual override, non-detenting, pack of 10	1 ... 9		...N	
	Cover for manual override, covered, pack of 10	1 ... 9		...V	

18 Can only be selected if there are more than 9 valve positions. Cannot be combined with DIN rail.

+ **20**

20

Ordering Data – ISO Thread

Pneumatic Connections

FESTO

Connection Sizes of The Pneumatic Connections (See Pages 60 and 64)			
		Width	
			18 mm (ISO 02) 26 mm (ISO 01)
7			Design of All Pneumatic Connections
4	Right-hand end plate	V, X, Y, U, Z, W	M, G (duct 12, 14) G $\frac{1}{4}$ (QS-G $\frac{1}{4}$ -10) G $\frac{1}{4}$ (QS-G $\frac{1}{4}$ -10)
			N (duct 12, 14) G $\frac{1}{4}$ (QS-G $\frac{1}{4}$ -8) G $\frac{1}{4}$ (QS-G $\frac{1}{4}$ -8)
4	Right-hand end plate	V, X, U	M, G (duct 1, 3, 5) QS-G $\frac{1}{2}$ -16 QS-G $\frac{1}{2}$ -16
			N (duct 1, 3, 5) QS-G $\frac{1}{2}$ -12 QS-G $\frac{1}{2}$ -12
9	Left-hand supply plate	X	M, G (duct 1, 3, 5) QS-G $\frac{1}{2}$ -16 QS-G $\frac{1}{2}$ -16
			N (duct 1, 3, 5) QS-G $\frac{1}{2}$ -12 QS-G $\frac{1}{2}$ -12
11	Type of interlinking block	Manifold subbase A, B, E, F	M (duct 2, 4) G $\frac{1}{8}$ (QS-G $\frac{1}{8}$ -8) G $\frac{1}{4}$ (QS-G $\frac{1}{4}$ -10)
		Manifold subbase with QS push-in fittings, small AK, BK, EK, FK	N (duct 2, 4) G $\frac{1}{8}$ (QS-G $\frac{1}{8}$ -6) G $\frac{1}{4}$ (QS-G $\frac{1}{4}$ -8)

Ordering Data – NPT Thread

Multi-pin Connection, Electrical Section

M Mandatory Data				O Options		
Module No.	Valve terminal, electrical part	Electrical connection	Voltage	Connecting cable for multi-pin plug connection	User's manual	DIN rail mounting
539216	44E	T, MP1, MP4	P, Q	GA, GB, GC, GD, GE, GF, GG, GH, GI, GK, GL, GM, GN, GO, GP, GQ, GR, GS	E, D, F, I, S, V	H
Order Example						
539216	44E	MP1	P	GE	D	7
1	2	3	4	5	6	7

Ordering Table			Conditions	Code	Enter Code
M 1	Module No.	539216			
2	Valve terminal, electrical part	Valve terminal type 44, VTSA, electrical multi-pin plug connection/terminal box		44E	44E
3	Electrical connection	Multi-pin plug, Cage Clamp	1	-T	
		Electrical multi-pin plug connection, Sub-D (37-pin)	1	-MP1	
		Electrical multi-pin plug connection, round plug connector (19-pin), M23	2	-MP4	
4	Voltage	24 V DC		-P	
		110 V AC	3	-Q	
O 5	Electrical accessories			+	+
	Connecting cable for multi-pin plug connection, pre-assembled, supplied loose	Polyurethane			
		Connecting cable for Sub-D, 2.5 m, 10-wire, 8 solenoid coils		GA	
		Connecting cable for Sub-D, 5 m, 10-wire, 8 solenoid coils		GB	
		Connecting cable for Sub-D, 10 m, 10-wire, 8 solenoid coils		GC	
		Connecting cable for Sub-D, 2.5 m, 26-wire, 22 solenoid coils		GD	
		Connecting cable for Sub-D, 5 m, 26-wire, 22 solenoid coils		GE	
		Connecting cable for Sub-D, 10 m, 26-wire, 22 solenoid coils		GF	
		Connecting cable for Sub-D, 2.5 m, 37-wire, 32 solenoid coils		GG	
		Connecting cable for Sub-D, 5 m, 37-wire, 32 solenoid coils		GH	
		Connecting cable for Sub-D, 10 m, 37-wire, 32 solenoid coils		GI	
		Polyvinyl chloride			
		Connecting cable for Sub-D, 2.5 m, 10-wire, 8 solenoid coils		GK	
		Connecting cable for Sub-D, 5 m, 10-wire, 8 solenoid coils		GL	
		Connecting cable for Sub-D, 10 m, 10-wire, 8 solenoid coils		GM	
		Connecting cable for Sub-D, 2.5 m, 27-wire, 22 solenoid coils		GN	
		Connecting cable for Sub-D, 5 m, 27-wire, 22 solenoid coils		GO	
		Connecting cable for Sub-D, 10 m, 27-wire, 22 solenoid coils		GP	
		Connecting cable for Sub-D, 2.5 m, 37-wire, 32 solenoid coils		GQ	
		Connecting cable for Sub-D, 5 m, 37-wire, 32 solenoid coils		GR	
Connecting cable for Sub-D, 10 m, 37-wire, 32 solenoid coils		GS			
6	User's manual	English		-E	
		German		-D	
		French		-F	
		Italian		-I	
		Spanish		-S	
		Swedish		-V	
7	DIN rail mounting	1		-H	

1 Max. 32 addresses can be actuated.
2 Max. 16 addresses can be actuated.

3 Only with electrical actuator T (multi-pin plug, Cage Clamp).

Transfer Order Code

539216	44E	-		-		+		-		-	
1	2		3		4		5		6		7

Ordering Data – NPT Thread

Multi-pin Connection, Pneumatic Section

M Mandatory Data				O Options →					
Module No.	Valve terminal, pneumatic part	Manual override	Right-hand end plate	Port design for supply plates	Pneumatic valve terminal supply	Design of all pneumatic connections	Outgoing direction of all working lines	Left-hand supply plate	Reverse operation
539216	44PN	N, R, V	V, X, Y, U, Z, W	K, L	S, V	M, N, G	P, O	X	Z
Order Example									
539216	44PN	- R	- V	- K	- S	- M	- P	- X	-
1	2	3	4	5	6	7	8	9	10

Ordering Table							
Width		18 mm (02)	26 mm (01)	Conditions	Code	Enter Code	
M 1	Module No.	539216	539216				
2	Valve terminal, pneumatic part	Valve terminal type 44, VTSA, modular subbase valves to ISO 15407-2, pneumatic connections with NPT thread				44PN	44PN
3	Manual override	Non-detenting				-N	
		Non-detenting/detenting				-R	
		Covered				-V	
4	Right-hand end plate	Right-hand end plate, with supply air/exhaust air, internal pilot air supply				-V	
		Right-hand end plate with supply air/exhaust air, external pilot air supply				-X	
		Selector end plate, internal pilot air supply			1	-Y	
		Selector end plate, internal pilot air supply, ducted exhaust air			1	-U	
		Selector end plate, external pilot air supply			1	-Z	
		Selector end plate, external pilot air supply, ducted exhaust air			1	-W	
O 5	Port design for supply plates	Normal operation: Supply port 1, exhaust port 3/5 separated			2	-K	
		Reverse operation: Exhaust port 1, supply port 3/5 separated					
		Normal operation: Supply port 1, exhaust port 3/5 common			2	-L	
		Reverse operation: Exhaust port 1, supply port 3/5 common					
6	Pneumatic valve terminal supply (standard: threaded connection)	Silencer and QS push-in fittings				S	
		QS push-in fittings				V	
7	Design of all pneumatic connections	QS push-in fittings, large			3	M	
		QS push-in fittings, small			3	N	
		QS push-in fittings, large and small mixed			3	G	
8	Outgoing direction of all working lines (standard outlet at front)	90° connection plate, outlet at bottom				P	
		90° connection plate, outlet at top				O	
9	Left-hand supply plate	Left-hand supply plate in front of manifold subbase 00				X	
O 10	Reverse operation	Reverse operation as of valve position 00			4	Z	

- 1 At least one left-hand supply plate (9) X or one compressed air supply/duct separation (12) U, SU, TU, RU, USU, UTU or URU must be selected.
- 2 Must be selected if left-hand supply plate (9) X or one compressed air supply/duct separation (12) (S, T, R, U, SU, US, TU, UT, RU, UR, USU, UTU, URU) was selected.
- 3 Must be selected if pneumatic valve terminal supply (6) S or V was selected. Connection sizes of the pneumatic connections → See table on Page 78.
- 4 A reversible pressure zone cannot be terminated with a right-hand end plate (4) V, Y, U (internal pilot air supply).

Transfer Order Code

539216	44PN	-		-		-				
1	2	3	4	5	6	7	8	9	10	

Ordering Data – NPT Thread

Multi-pin Connection, Pneumatic Section

→ **0** Options →

Pneumatic manifold subbases 00 ... 15

- 11 Type of interlinking block:** A, B, E, F, AK, BK, EK, FK
- 12 Compressed air supply/duct separation:** S, T, R, U, SU, US, TU, UT, RU, UR, USU, UTU, URU
- 13 Reverse operation:** Z

Module Position

00	01	02	03	04	05	06	07	08	09	10	11	12	13	14	15
A	B	B	B	S	B										

11 + 12 + 13

Ordering Table							
Width			18 mm (ISO 02)	26 mm (ISO 01)	Conditions	Code	Enter Code
↓	11	Pneumatic manifold subbases			5	-	-
0	Type of interlinking block 00 ... 15	Manifold subbase	2 valve positions, 4 addresses	-		A	Enter the equipment selected in the order code
			-	2 valve positions, 4 addresses		B	
			2 valve positions, 2 addresses	-		E	
			-	2 valve positions, 2 addresses		F	
		Manifold subbase with QS push-in fittings, small	2 valve positions, 4 addresses	-		AK	
			-	2 valve positions, 4 addresses		BK	
			2 valve positions, 2 addresses	-		EK	
			-	2 valve positions, 2 addresses		FK	
	12 Compressed air supply/duct separation 00... 15	Duct separation 1, 3, 5			9 10	S	
		Duct separation 1			9 10	T	
		Duct separation 3, 5			9 10	R	
		Supply plate				U	
		Supply plate with duct separation 1, 3, 5 at left			9	SU	
		Supply plate with duct separation 1, 3, 5 at right			9	US	
		Supply plate with duct separation 1 at left			9	TU	
		Supply plate with duct separation 1 at right			9	UT	
		Supply plate with duct separation 3, 5 at left			9	RU	
		Supply plate with duct separation 3, 5 at right			9	UR	
		2 supply plates with duct separation 1, 3, 5 in center				USU	
		2 supply plates with duct separation 1 in center				UTU	
		2 supply plates with duct separation 3, 5 in center				URU	
↓	13	Reverse operation 00 ... 15	Subsequent valve positions permitted for reverse operation		11	Z	

- 5** Manifold subbases must be equipped throughout without any gaps.
- 6** Only with valves (14) M, O and L.
- 7** Not with design of all pneumatic connections (7) M or N.
- 8** Not with design of all pneumatic connections (7) M or N. Only with valves (14) M, O and L.

- 9** No pressure-free zones may be created.
- 10** Cannot be selected on last manifold subbase.
- 11** Only with compressed air supply/duct separation (12) S, SU, US or USU.
A reversible pressure zone cannot be terminated with a right-hand end plate (4) Y, Y, U.

Transfer Order Code

00	01	02	03	04	05	06	07	08	09	10	11	12	13	14	15

11 + 12 + 13

Ordering Data – NPT Thread

Multi-pin Connection, Pneumatic Section



→ 0 Options →

Pneumatic Valve Positions 00 ... 31

- 14 Valve position 00 ... 31: M, O, J, D, N, K, H, B, G, E, P, Q, R, L
- 15 Pressure regulator for position 00 ... 31: ZA, ZB, ZC, ZD, ZE, ZF, ZG, ZH, ZI, ZJ
- 16 Pressure indicator for position 00 ... 31: T, U
- 17 Flow control valve position 00 ... 31: X
- 18 Pressure indicator for position 00 ... 31: ZT
- 19 Vertical supply plate for position 00 ... 31: ZU

Valve Position		00	01	02	03	04	05	06	07	08	09	10	11	12	13	14	15	16	17	18	19	20	...	30	31
-		M	M	M	O	O	O	J	J	E	E												...		

14 + 15 + 16 + 17 + 18 + 19

Ordering Table							
Width	18 mm (ISO 02)		26 mm (ISO 01)		Conditions	Code	Enter Code
↓ 14	Pneumatic valve positions 00 ... 31					-	-
0	Valve position	5/2-way valve, single solenoid with pneumatic spring return				M	Enter equipment selection for valve positions in order code
		5/2-way valve, single solenoid with spring return				O	
		5/2-way valve, double solenoid				J	
		5/2-way valve, double solenoid with dominant signal				D	
		2x 3/2-way valve, normally open			12	N	
		2x 3/2-way valve, normally closed			12	K	
		2x 3/2-way valve, 1x normally closed, 1x normally open			12	H	
		5/3-way valve, mid-position pressurized				B	
		5/3-way valve, mid-position closed				G	
		5/3-way valve, mid-position exhausted				E	
		2x 3/2-way valve, normally open, reverse operation			13	P	
		2x 3/2-way valve, normally closed, reverse operation			13	Q	
		2x 3/2-way valve, 1x normally closed, 1x normally open, reverse operation			13	R	
		Vacant position				L	
15	Pressure regulator	Input pressure 10 bar	Pressure regulator for port 1				ZA
			Pressure regulator for port 4				ZB
			Pressure regulator for port 2				ZC
			Pressure regulator for port 4/2				ZD
			Pressure regulator for port 4/2, reversible			14	ZE
	Input pressure 6 bar	Pressure regulator for port 1					ZF
		Pressure regulator for port 4					ZG
		Pressure regulator for port 2					ZH
		Pressure regulator for port 4/2					ZI
		Pressure regulator for port 4/2, reversible			14		ZJ
16	Pressure indicator	Pressure gauge, 10 bar			15	T	
		Pressure gauge, 6 bar			16	U	
17	Flow control valve	Flow control valve			17	X	
18	Vertical isolating plate	Pressure separator plate on valve assembly				ZT	
19	Vertical supply plate	Compressed air supply on valve			17	ZU	

- 12 Not permissible in zones with exhaust air in duct 1 and compressed air in duct 3, 5.
- 13 Only permissible in zones with reverse operation.
- 14 Not with 2x 3/2-way valves (14) N, K, H.
- 15 Only with pressure regulator (15) ZA, ZB, ZC, ZD, ZE.
- 16 Only with pressure regulator (15) ZF, ZG, ZH, ZI, ZJ.
- 17 Not with valves with reverse operation (14) P, Q, R.

Transfer Order Code

		00	01	02	03	04	05	06	07	08	09	10	11	12	13	14	15	16	17	18	19	20	...	30	31
-																							...		

14 + 15 + 16 + 17 + 18 + 19

Ordering Data – NPT Thread

Multi-pin Connection, Pneumatic Section

→ **0** Options

Pneumatic Accessories

U, ...B, ...T, ...N, ...V

+ **2N**

20

Ordering Table					
Width	18 mm (ISO 02)	26 mm (ISO 01)	Conditions	Code	Enter Code
↓ 20	Pneumatic accessories			+	+
0	Mounting bracket	Ready-mounted	18	U	
	Label holder for valves	1 ... 99		...B	
	Label holder for manifold subbases	1 ... 99		...T	
	Cover for manual override, non-detenting, pack of 10	1 ... 9		...N	
	Cover for manual override, covered, pack of 10	1 ... 9		...V	

18 Can only be selected if there are more than 9 valve positions.

+ **20**

20

Ordering Data – NPT Thread

CPX Fieldbus Connection, Pneumatic Section

M Mandatory Data				O Options →					
Module No.	Valve terminal, pneumatic part	Manual override	Right-hand end plate	Port design for supply plates	Pneumatic valve terminal supply	Design of all pneumatic connections	Outgoing direction of all working lines	Left-hand supply plate	Reverse operation
539218	44PN	N, R, V	V, X, Y, U, Z, W	K, L	S, V	M, N, G	P, O	X	Z
Order Example									
539218	44PN	R	V	K	S	M	P	X	Z
1	2	3	4	5	6	7	8	9	10

Ordering Table							
Width		18 mm (02)	26 mm (01)	Conditions	Code	Enter Code	
M 1	Module No.	539218	539218				
2	Valve terminal, pneumatic part	Valve terminal type 44, VTSA, modular subbase valves to ISO 15407-2, pneumatic connections with NPT thread				44PN	44PN
3	Manual override	Non-locking				-N	
		Non-detenting/detenting				-R	
		Covered				-V	
4	Right-hand end plate	Right-hand end plate, with supply air/exhaust air, internal pilot air supply				-V	
		Right-hand end plate with supply air/exhaust air, external pilot air supply				-X	
		Selector end plate, internal pilot air supply			1	-Y	
		Selector end plate, internal pilot air supply, ducted exhaust air			1	-U	
		Selector end plate, external pilot air supply			1	-Z	
		Selector end plate, external pilot air supply, ducted exhaust air			1	-W	
O 5	Port design for supply plates	Normal operation: Supply port 1, exhaust port 3/5 separated			2	-K	
		Reverse operation: Exhaust port 1, supply port 3/5 separated					
		Normal operation: Supply port 1, exhaust port 3/5 common			2	-L	
		Reverse operation: Exhaust port 1, supply port 3/5 common					
6	Pneumatic valve terminal supply (standard: threaded connection)	Silencer and QS push-in fittings				S	
		QS push-in fittings				V	
7	Design of all pneumatic connections	QS push-in fittings, large			3	M	
		QS push-in fittings, small			3	N	
		QS push-in fittings, large and small mixed			3	G	
8	Outgoing direction of all working lines (standard outlet at front)	90° connection plate, outlet at bottom				P	
		90° connection plate, outlet at top				O	
9	Left-hand supply plate	Left-hand supply plate in front of manifold subbase 00				X	
O 10	Reverse operation	Reverse operation as of valve position 00			4	Z	

- 1 At least one left-hand supply plate (9) X or one compressed air supply/duct separation (12) U, SU, TU, RU, USU, UTU or URU must be selected.
- 2 Must be selected if left-hand supply plate (9) X or one compressed air supply/duct separation (12) (S, T, R, U, SU, US, TU, UT, RU, UR, USU, UTU, URU) was selected.
- 3 Must be selected if pneumatic valve terminal supply (6) S or V was selected. Connection sizes of the pneumatic connections → See table on Page 78.
- 4 A reversible pressure zone cannot be terminated with a right-hand end plate (4) V, Y, U (internal pilot air supply).

Transfer Order Code

539218	44PN	-		-		-				
1	2	3	4	5	6	7	8	9	10	

Ordering Data – NPT Thread

CPX Fieldbus Connection, Pneumatic Section

→ 0 Options →

Pneumatic Manifold Subbases 00 ... 15

11 Type of interlinking block: A, B, E, F, AK, BK, EK, FK
 12 Compressed air supply/duct separation: S, T, R, U, SU, US, TU, UT, RU, UR, USU, UTU, URU
 13 Reverse operation: Z

Module Position

00 01 02 03 04 05 06 07 08 09 10 11 12 13 14 15

A	B	B	B	S	B										
---	---	---	---	---	---	--	--	--	--	--	--	--	--	--	--

11 + 12 + 13

Ordering Table								
Width			18 mm (ISO 02)	26 mm (ISO 01)	Conditions	Code	Enter Code	
11	Pneumatic manifold subbases				5	-	-	
0	Type of interlinking block 00 ... 15	Manifold subbase	2 valve positions, 4 addresses	-		A	Enter the equipment selected in the order code	
			-	2 valve positions, 4 addresses		B		
		Manifold subbase with QS push-in fittings, small	2 valve positions, 2 addresses	-	6	E		
			-	2 valve positions, 2 addresses	6	F		
	12	Compressed air supply/duct separation 00... 15	Manifold subbase with QS push-in fittings, small	2 valve positions, 4 addresses	-	7		AK
				-	2 valve positions, 4 addresses	7		BK
			2 valve positions, 2 addresses	-	8	EK		
				-	2 valve positions, 2 addresses	8		FK
13	Reverse operation 00 ... 15		Duct separation 1, 3, 5		9 10	S		
			Duct separation 1		9 10	T		
			Duct separation 3, 5		9 10	R		
			Supply plate			U		
			Supply plate with duct separation 1, 3, 5 at left		9	SU		
			Supply plate with duct separation 1, 3, 5 at right		9	US		
			Supply plate with duct separation 1 at left		9	TU		
			Supply plate with duct separation 1 at right		9	UT		
			Supply plate with duct separation 3, 5 at left		9	RU		
			Supply plate with duct separation 3, 5 at right		9	UR		
			2 supply plates with duct separation 1, 3, 5 in center			USU		
			2 supply plates with duct separation 1 in center			UTU		
		2 supply plates with duct separation 3, 5 in center			URU			
		Subsequent valve positions permitted for reverse operation			11	Z		

- 5 Manifold subbases must be equipped throughout without any gaps.
- 6 Only with valves (14) M, O and L.
- 7 Not with design of all pneumatic connections (7) M or N.
- 8 Not with design of all pneumatic connections (7) M or N. Only with valves (14) M, O and L.

- 9 No pressure-free zones may be created.
- 10 Cannot be selected on last manifold subbase.
- 11 Only with compressed air supply/duct separation (12) S, SU, US or USU.
A reversible pressure zone cannot be terminated with a right-hand end plate (4) Y, Y, U.

Transfer Order Code

00 01 02 03 04 05 06 07 08 09 10 11 12 13 14 15

--	--	--	--	--	--	--	--	--	--	--	--	--	--	--	--

11 + 12 + 13

Ordering Data – NPT Thread

CPX Fieldbus Connection, Pneumatic Section



→ 0 Options →

Pneumatic Valve Positions 00 ... 31

- 14 Valve position 00 ... 31: M, O, J, D, N, K, H, B, G, E, P, Q, R, L
- 15 Pressure regulator for position 00 ... 31: ZA, ZB, ZC, ZD, ZE, ZF, ZG, ZH, ZI, ZJ
- 16 Pressure indicator for position 00 ... 31: T, U
- 17 Flow control valve position 00 ... 31: X
- 18 Pressure indicator for position 00 ... 31: ZT
- 19 Vertical supply plate for position 00 ... 31: ZU

Valve Position

00	01	02	03	04	05	06	07	08	09	10	11	12	13	14	15	16	17	18	19	20	...	30	31
M	M	M	O	O	O	J	J	E	E												...		

14 + 15 + 16 + 17 + 18 + 19

Ordering Table

Width	18 mm (ISO 02)	26 mm (ISO 01)	Conditions	Code	Enter Code
14	Pneumatic valve positions 00 ... 31			-	-
0	Valve position	5/2-way valve, single solenoid with pneumatic spring return		M	Enter equipment selection for valve positions in order code
		5/2-way valve, single solenoid with mechanical spring return		O	
		5/2-way valve, double solenoid		J	
		5/2-way valve, double solenoid with dominant signal		D	
		2x 3/2-way valve, normally open	12	N	
		2x 3/2-way valve, normally closed	12	K	
		2x 3/2-way valve, 1x normally closed, 1x normally open	12	H	
		5/3-way valve, mid-position pressurized		B	
		5/3-way valve, mid-position closed		G	
		5/3-way valve, mid-position exhausted		E	
		2x 3/2-way valve, normally open, reverse operation	13	P	
		2x 3/2-way valve, normally closed, reverse operation	13	Q	
		2x 3/2-way valve, 1x normally closed, 1x normally open, reverse operation	13	R	
		Spare position		L	
15	Pressure regulator	Input pressure 10 bar	Pressure regulator for port 1		ZA
			Pressure regulator for port 4		ZB
			Pressure regulator for port 2		ZC
			Pressure regulator for port 4/2		ZD
			Pressure regulator for port 4/2, reversible	14	ZE
	Input pressure 6 bar	Pressure regulator for port 1		ZF	
		Pressure regulator for port 4		ZG	
		Pressure regulator for port 2		ZH	
		Pressure regulator for port 4/2		ZI	
		Pressure regulator for port 4/2, reversible	14	ZJ	
16	Pressure indicator	Pressure gauge, 10 bar	15	T	
		Pressure gauge, 6 bar	16	U	
17	Flow control valve	Flow control valve	17	X	
18	Vertical isolating plate	Pressure separator plate on valve assembly		ZT	
19	Vertical supply plate	Compressed air supply on valve	17	ZU	

12 Not permissible in zones with exhaust air in duct 1 and compressed air in duct 3, 5.

13 Only permissible in zones with reverse operation.

14 Not with 2x 3/2-way valves (14) N, K, H.

15 Only with pressure regulator (15) ZA, ZB, ZC, ZD, ZE.

16 Only with pressure regulator (15) ZF, ZG, ZH, ZI, ZJ.

17 Not with valves with reverse operation (14) P, Q, R.

Transfer Order Code

00	01	02	03	04	05	06	07	08	09	10	11	12	13	14	15	16	17	18	19	20	...	30	31
																					...		

14 + 15 + 16 + 17 + 18 + 19

Ordering Data – NPT Thread

CPX Fieldbus Connection, Pneumatic Section

→ **0** Options

Pneumatic Accessories

U, ...B, ...T, ...N, ...V

+ **2N**

20

Ordering Table					
Width	18 mm (ISO 02)	26 mm (ISO 01)	Conditions	Code	Enter Code
↓ 20	Pneumatic accessories			+	+
0	Mounting bracket	Ready-mounted	18	U	
	Label holder for valves	1 ... 99		...B	
	Label holder for manifold subbases	1 ... 99		...T	
	Cover for manual override, non-detenting, pack of 10	1 ... 9		...N	
	Cover for manual override, covered, pack of 10	1 ... 9		...V	

18 Can only be selected if there are more than 9 valve positions. Cannot be combined with DIN rail.

+ **20**

20

Ordering Data – NPT Thread

Pneumatic Connections

FESTO

Connection Sizes of The Pneumatic Connections (See Pages 70 and 74)			
		Width	
			18 mm (ISO 02) 26 mm (ISO 01)
7			Design of All Pneumatic Connections
4	Right-hand end plate	V, X, Y, U, Z, W	M, G (duct 12, 14) 1/4 NPT (QS-1/4-3/8-U) 1/4 NPT (QS-1/4-3/8-U)
			N (duct 12, 14) 1/4 NPT (QS-1/4-5/16-U) 1/4 NPT (QS-1/4-5/16-U)
4	Right-hand end plate	V, X, U	M, G (duct 1, 3, 5) QS-1/2-5/8-U QS-1/2-5/8-U
			N (duct 1, 3, 5) QS-1/2-1/2-U QS-1/2-1/2-U
9	Left-hand supply plate	X	M, G (duct 1, 3, 5) QS-1/2-5/8-U QS-1/2-5/8-U
			N (duct 1, 3, 5) QS-1/2-1/2-U QS-1/2-1/2-U
11	Type of interlinking block	Manifold subbase A, B, E, F	M (duct 2, 4) 1/8 NPT (QS-1/8-5/16-U) 1/4 NPT (QS-1/4-3/8-U)
		Manifold subbase with QS push-in fittings, small AK, BK, EK, FK	N (duct 2, 4) 1/8 NPT (QS-1/8-1/4-U) 1/4 NPT (QS-G1/4-5/16-U)

Ordering Data

Individual Valves



Ordering Data					
	Code	Valve Function	Size	Type	Part No.
Solenoid Valves, 24 V DC, Port Pattern to ISO 15407-2					
	M	5/2-way valve, single solenoid, pneumatic spring return	02	VSVA-B-M52-AZD-A2-1T1L	539184
			01	VSVA-B-M52-AZD-A1-1T1L	539158
	O	5/2-way valve, single solenoid, spring return	02	VSVA-B-M52-MZD-A2-1T1L	539185
			01	VSVA-B-M52-MZD-A1-1T1L	539159
	J	5/2-way valve, double solenoid	02	VSVA-B-B52-ZD-A2-1T1L	539182
			01	VSVA-B-B52-ZD-A1-1T1L	539156
	D	5/2-way valve, double solenoid, dominating signal	02	VSVA-B-D52-ZD-A2-1T1L	539183
			01	VSVA-B-D52-ZD-A1-1T1L	539157
	N	2x 3/2-way valve, single solenoid, normally open	02	VSVA-B-T32U-AZD-A2-1T1L	539178
			01	VSVA-B-T32U-AZD-A1-1T1L	539152
	K	2x 3/2-way valve, single solenoid, normally closed	02	VSVA-B-T32C-AZD-A2-1T1L	539176
			01	VSVA-B-T32C-AZD-A1-1T1L	539150
	H	2x 3/2-way valve, single solenoid, 1x normally open, 1x normally closed	02	VSVA-B-T32H-AZD-A2-1T1L	539180
			01	VSVA-B-T32H-AZD-A1-1T1L	539154
	B	5/3-way valve, mid-position pressurized	02	VSVA-B-P53U-ZD-A2-1T1L	539186
			01	VSVA-B-P53U-ZD-A1-1T1L	539160
	G	5/3-way valve, mid-position closed	02	VSVA-B-P53C-ZD-A2-1T1L	539188
			01	VSVA-B-P53C-ZD-A1-1T1L	539162
E	5/3-way valve, mid-position exhausted	02	VSVA-B-P53E-ZD-A2-1T1L	539187	
		01	VSVA-B-P53E-ZD-A1-1T1L	539161	
P	2x 3/2-way valve, single solenoid, reverse operation, normally open	02	VSVA-B-T32F-AZD-A2-1T1L	539179	
		01	VSVA-B-T32F-AZD-A1-1T1L	539153	
Q	2x 3/2-way valve, single solenoid, reverse operation, normally closed	02	VSVA-B-T32N-AZD-A2-1T1L	539177	
		01	VSVA-B-T32N-AZD-A1-1T1L	539151	
R	2x 3/2-way valve, single solenoid, reverse operation, 1x normally open, 1x normally closed	02	VSVA-B-T32W-AZD-A2-1T1L	539181	
		01	VSVA-B-T32W-AZD-A1-1T1L	539155	
Solenoid Valves, 110 V AC, Port Pattern to ISO 15407-2					
	M	5/2-way valve, single solenoid, pneumatic spring return	02	VSVA-B-M52-AZD-A2-2AT1L	539171
			01	VSVA-B-M52-AZD-A1-2AT1L	539145
	O	5/2-way valve, single solenoid, spring return	02	VSVA-B-M52-MZD-A2-2AT1L	539172
			01	VSVA-B-M52-MZD-A1-2AT1L	539146
	J	5/2-way valve, double solenoid	02	VSVA-B-B52-ZD-A2-2AT1L	539169
			01	VSVA-B-B52-ZD-A1-2AT1L	539143
	D	5/2-way valve, double solenoid, dominating signal	02	VSVA-B-D52-ZD-A2-2AT1L	539170
			01	VSVA-B-D52-ZD-A1-2AT1L	539144
	N	2x 3/2-way valve, single solenoid, normally open	02	VSVA-B-T32U-AZD-A2-2AT1L	539165
			01	VSVA-B-T32U-AZD-A1-2AT1L	539139
	K	2x 3/2-way valve, single solenoid, normally closed	02	VSVA-B-T32C-AZD-A2-2AT1L	539163
			01	VSVA-B-T32C-AZD-A1-2AT1L	539137
	H	2x 3/2-way valve, single solenoid, 1x normally open, 1x normally closed	02	VSVA-B-T32H-AZD-A2-2AT1L	539167
			01	VSVA-B-T32H-AZD-A1-2AT1L	539141
	B	5/3-way valve, mid-position pressurized	02	VSVA-B-P53U-ZD-A2-2AT1L	539173
			01	VSVA-B-P53U-ZD-A1-2AT1L	539147
	G	5/3-way valve, mid-position closed	02	VSVA-B-P53C-ZD-A2-2AT1L	539175
			01	VSVA-B-P53C-ZD-A1-2AT1L	539149
E	5/3-way valve, mid-position exhausted	02	VSVA-B-P53E-ZD-A2-2AT1L	539174	
		01	VSVA-B-P53E-ZD-A1-2AT1L	539148	
P	2x 3/2-way valve, single solenoid, reverse operation, normally open	02	VSVA-B-T32F-AZD-A2-2AT1L	539166	
		01	VSVA-B-T32F-AZD-A1-2AT1L	539140	
Q	2x 3/2-way valve, single solenoid, reverse operation, normally closed	02	VSVA-B-T32N-AZD-A2-2AT1L	539164	
		01	VSVA-B-T32N-AZD-A1-2AT1L	539138	
R	2x 3/2-way valve, single solenoid, reverse operation, 1x normally open, 1x normally closed	02	VSVA-B-T32W-AZD-A2-2AT1L	539168	
		01	VSVA-B-T32W-AZD-A1-2AT1L	539142	

Ordering Data

End Plates and Subbases

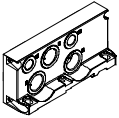
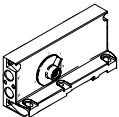
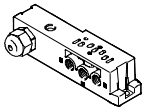
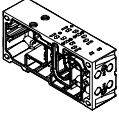
FESTO

Ordering Data					
Designation	Code	Description	Size	Type	Part No.
Right-hand End Plate					
	G Thread				
	V	With supply air/exhaust air, internal pilot air supply, G $\frac{1}{2}$		VABE-S6-1R-G12	539234
	X	With supply air/exhaust air, external pilot air supply, G $\frac{1}{2}$		VABE-S6-1RZ-G12	539236
	NPT Thread				
	V	With supply air/exhaust air, internal pilot air supply, $\frac{1}{2}$ NPT		VABE-S6-1R-N12	539235
X	With supply air/exhaust air, external pilot air supply, $\frac{1}{2}$ NPT		VABE-S6-1RZ-N12	539237	
Selector End Plate					
	G Thread				
	Y	Internal pilot air supply		VABE-S6-1RZ-G-B1	539238
	U	Internal pilot air supply, ducted pilot exhaust air			
	Z	External pilot air supply			
	W	External pilot air supply, ducted pilot exhaust air			
	NPT Thread				
	Y	Internal pilot air supply		VABE-S6-1RZ-N-B1	539239
	U	Internal pilot air supply, ducted pilot exhaust air			
	Z	External pilot air supply			
	W	External pilot air supply, ducted pilot exhaust air			
Individual Subbase, Port Pattern to ISO 15407-2					
	G Thread, Internal Pilot Air Supply				
	-	Connections at side, G $\frac{1}{8}$, M12 plug	02	VABS-S4-2S-G18-B-R3	541070
	-	Connections at side, G $\frac{1}{8}$, terminals	02	VABS-S4-2S-G18-B-K2	541067
	-	Connections at side, G $\frac{1}{4}$, M12 plug	01	VABS-S4-1S-G14-B-R3	541069
	-	Connections at side, G $\frac{1}{4}$, terminals	01	VABS-S4-1S-G14-B-K2	541065
	G Thread, External Pilot Air Supply				
	-	Connections at side, G $\frac{1}{4}$, M12 plug	01	VABS-S4-1S-G14-R3	541063
	-	Connections at side, G $\frac{1}{4}$, terminals	01	VABS-S4-1S-G14-K2	539725
	-	Connections at side, G $\frac{1}{8}$, M12 plug	02	VABS-S4-2S-G18-R3	541064
	-	Connections at side, G $\frac{1}{8}$, terminals	02	VABS-S4-2S-G18-K2	539723
	NPT Thread, Internal Pilot Air Supply				
	-	Connections at side, external pilot air supply, $\frac{1}{2}$ NPT, terminals	02	VABS-S4-2S-N18-B-K2	541068
	-	Connections at side, external pilot air supply, $\frac{1}{2}$ NPT, terminals	01	VABS-S4-1S-N14-B-K2	541066
	NPT Thread, External Pilot Air Supply				
	-	Connections at side, $\frac{1}{2}$ NPT, terminals	02	VABS-S4-2S-N18-K2	539724
	-	Connections at side, $\frac{1}{2}$ NPT, terminals	01	VABS-S4-1S-N14-K2	539726
Manifold Subbase, Port Pattern to ISO 15407-2					
	G Thread				
	A	2 valve positions, 4 addresses, for double solenoid valves	02	VABV-S4-2S-G18-2T2	539224
	B	2 valve positions, 4 addresses, for double solenoid valves	01	VABV-S4-1S-G14-2T2	539220
	E	2 valve positions, 2 addresses, for single solenoid valves	02	VABV-S4-2S-G18-2T1	539226
	F	2 valve positions, 2 addresses, for single solenoid valves	01	VABV-S4-1S-G14-2T1	539222
	NPT Thread				
	A	2 valve positions, 4 addresses, for double solenoid valves	02	VABV-S4-2S-N18-2T2	539223
	B	2 valve positions, 4 addresses, for double solenoid valves	01	VABV-S4-1S-N14-2T2	539219
	E	2 valve positions, 2 addresses, for single solenoid valves	02	VABV-S4-2S-N18-2T1	539225
	F	2 valve positions, 2 addresses, for single solenoid valves	01	VABV-S4-1S-N14-2T1	539221

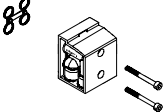
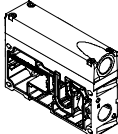
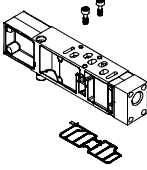
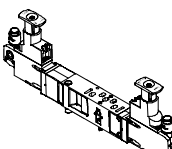
Ordering Data					
Designation	Code	Description	Size	Type	Part No.
Separator Plate					
	S	Duct separation 1, 3, 5		VABD-S6-10-P3-C	539228
	T	Duct separation 1		VABD-S6-10-P1-C	539227
	R	Duct separation 3, 5		VABD-S6-10-P2-C	539229
90° Connection Plate					
	G Thread				
	P/O	Outlet at bottom/top, connecting thread G $\frac{1}{8}$	02	VABF-S4-2-A2G2-G18	539719
	P/O	Outlet at bottom/top, connecting thread G $\frac{1}{4}$	01	VABF-S4-1-A2G2-G14	539721
	NPT Thread				
	P/O	Outlet at bottom/top, connecting thread $\frac{1}{8}$ NPT	02	VABF-S4-2-A2G2-N18	539720
P/O	Outlet at bottom/top, connecting thread $\frac{1}{4}$ NPT	01	VABF-S4-1-A2G2-N14	539722	
Supply Plate					
	G Thread				
	L	With exhaust plate, 3/5 common, G $\frac{1}{2}$		VABF-S6-10-P1A7-G12	539231
	K	With exhaust port cover, 3/5 separated, G $\frac{1}{2}$		VABF-S6-10-P1A6-G12	539230
	NPT Thread				
	L	With exhaust plate, 3/5 common, $\frac{1}{2}$ NPT		VABF-S6-10-P1A7-N12	539233
K	With exhaust port cover, 3/5 separated, $\frac{1}{2}$ NPT		VABF-S6-10-P1A6-N12	539232	
Vertical Supply Plate					
	G Thread				
	ZU	Connecting thread G $\frac{3}{8}$	02	VABF-S4-2-P1A3-G18	540173
		Connecting thread G $\frac{1}{4}$	01	VABF-S4-1-P1A3-G14	540171
	NPT Thread				
	ZU	Connecting thread $\frac{1}{8}$ NPT	02	VABF-S4-2-P1A3-N18	540174
	Connecting thread $\frac{1}{4}$ NPT	01	VABF-S4-1-P1A3-N14	540172	
Regulator Block					
	ZA	For port 1, 10 bar	02	VABF-S4-2-R1C2-C-10	540153
		For port 1, 10 bar	01	VABF-S4-1-R1C2-C-10	540154
	ZF	For port 1, 6 bar	02	VABF-S4-2-R1C2-C-6	540151
		For port 1, 6 bar	01	VABF-S4-1-R1C2-C-6	540152
	ZB	For port 4, 10 bar	02	VABF-S4-2-R3C2-C-10	540157
		For port 4, 10 bar	01	VABF-S4-1-R3C2-C-10	540158
	ZG	For port 4, 6 bar	02	VABF-S4-2-R3C2-C-6	540155
		For port 4, 6 bar	01	VABF-S4-1-R3C2-C-6	540156
	ZC	For port 2, 10 bar	02	VABF-S4-2-R2C2-C-10	540161
		For port 2, 10 bar	01	VABF-S4-1-R2C2-C-10	540162
	ZH	For port 2, 6 bar	02	VABF-S4-2-R2C2-C-6	540159
		For port 2, 6 bar	01	VABF-S4-1-R2C2-C-6	540160
	ZD	For port 2 and 4, 10 bar	02	VABF-S4-2-R4C2-C-10	540165
		For ports 2 and 4, 10 bar	01	VABF-S4-1-R4C2-C-10	540166
	ZI	For ports 2 and 4, 6 bar	02	VABF-S4-2-R4C2-C-6	540163
		For ports 2 and 4, 6 bar	01	VABF-S4-1-R4C2-C-6	540164
	ZE	For ports 2 and 4, reversible, 10 bar	02	VABF-S4-2-R5C2-C-10	540169
		For ports 2 and 4, reversible, 10 bar	01	VABF-S4-1-R5C2-C-10	540170
	ZJ	For ports 2 and 4, reversible, 6 bar	02	VABF-S4-2-R5C2-C-6	540167
		For ports 2 and 4, reversible, 6 bar	01	VABF-S4-1-R5C2-C-6	540168

Ordering Data

Pneumatic and Electrical Components



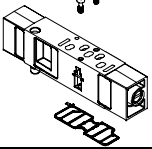
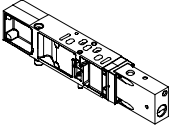
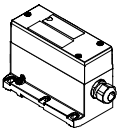
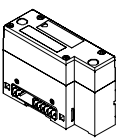
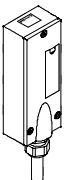



FESTO

Ordering Data					
Designation	Code	Description	Type	Part No.	
Pressure Gauge					
	T	With cartridge connection, 16 bar – For regulator block, code ZA, ZB, ZC, ZD, ZE	PAGN-26-16-P10	543487	
	U	With cartridge connection, 6 bar – For regulator block, code ZF, ZG, ZH, ZI, ZJ	PAGN-26-10-P10	543488	
Throttle Plate					
	X	Size 02	VABF-S4-2-F1B1-C	540176	
		Size 01	VABF-S4-1-F1B1-C	540175	
Vertical Isolating Plate					
	ZT	Size 02	VABF-S4-2-L1D1-C	542884	
		Size 01	VABF-S4-1-L1D1-C	542885	
Multi-pin Node					
	T	Tension spring, for metric connection, 36-pin	VABE-S6-1LF-C-M1-C36M	543412	
		Tension spring, for NPT connection, 36-pin	VABE-S6-1LF-C-M1-C36N	543413	
	MP1	Sub-D plug, 37-pin	VABE-S6-1LT-C-M1-S37	543414	
	MP4	Round plug, 19-pin	VABE-S6-1LF-C-M1-R19	543415	
Pneumatic Interface					
		For electrical terminal CPX	VABA-1S6-X1	543416	
Multi-pin Cable with Sub-D Plug Socket					
	Polyurethane, IP65				
	GA	Connecting cable for max. 8 solenoid coils, 10-pin, suitable for chain link trunking	2.5 m	NEBV-S1W37-E2.5-LE10	539240
	GB		5 m	NEBV-S1W37-E5-LE10	539241
	GC		10 m	NEBV-S1W37-E10-LE10	539242
	GD	Connecting cable for max. 22 solenoid coils, 26-pin, suitable for chain link trunking	2.5 m	NEBV-S1W37-E2.5-LE26	539243
	GE		5 m	NEBV-S1W37-E5-LE26	539244
	GF		10 m	NEBV-S1W37-E10-LE26	539245
	GG	Connecting cable for max. 32 solenoid coils, 37-pin	2.5 m	NEBV-S1W37-K2.5-LE37	539246
	GH		5 m	NEBV-S1W37-K5-LE37	539247
	GI		10 m	NEBV-S1W37-K10-LE37	539248
	Polyvinyl Chloride, IP65				
	GA	Connecting cable for max. 8 solenoid coils, 10-pin	2.5 m	NEBV-S1W37-KM-2.5-LE10	543271
	GB		5 m	NEBV-S1W37-KM-5-LE10	543272
	GC		10 m	NEBV-S1W37-KM-10-LE10	543273
	GD	Connecting cable for max. 22 solenoid coils, 27-pin	2.5 m	NEBV-S1W37-KM-2.5-LE27	543274
	GE		5 m	NEBV-S1W37-KM-5-LE27	543275
	GF		10 m	NEBV-S1W37-KM-10-LE27	543276
	GG	Connecting cable for max. 32 solenoid coils, 37-pin	2.5 m	NEBV-S1W37-KM-2.5-LE37	543277
	GH		5 m	NEBV-S1W37-KM-5-LE37	543278
	GI		10 m	NEBV-S1W37-KM-10-LE37	543279

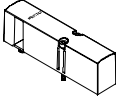
Accessories

Pneumatic Components

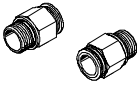
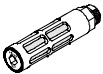

FESTO

Ordering Data					
Designation	Code	Description	Type	Part No.	
Cover					
	L	Blanking plate for vacant position	Size 02	VABB-S4-2-WT	539213
			Size 01	VABB-S4-1-WT	539212
	N	Cover cap for manual override, non-detenting	10 pieces	VAMC-S6-CH	541010
	V	Cover for manual override, covered	10 pieces	VAMC-S6-CS	541011
Label Holder					
	B	Clip-on label holder for valve cap		ASLR-T-S6	540888
	T	Label holder for manifold blocks		ASLR-M-S6	540889
Push-in Fitting					
	G Thread				
	-	Connecting thread G1/4	For tubing O.D. 10 mm (10 pieces)	QS-G1/4-10	186101
		Connecting thread G1/4	For tubing O.D. 8 mm (10 pieces)	QS-G1/4-8	186099
		Connecting thread G3/8	For tubing O.D. 8 mm (10 pieces)	QS-G3/8-8	186098
		Connecting thread G3/8	For tubing O.D. 6 mm (10 pieces)	QS-G3/8-6	186096
		Connecting thread G1/2	For tubing O.D. 12 mm	QS-G1/2-12	186104
		Connecting thread G1/2	For tubing O.D. 16 mm	QS-G1/2-16	186105
		Connecting thread G3/8	For tubing O.D. 10 mm (10 pieces)	QS-G3/8-10	186102
		Connecting thread G3/8	For tubing O.D. 12 mm (10 pieces)	QS-G3/8-12	186103
	NPT Thread				
	-	Connecting thread 1/4 NPT	For tubing O.D. 3/8"	QS-1/4-3/8-U	153611
		Connecting thread 1/4 NPT	For tubing O.D. 5/16"	QS-1/4-5/16-U	153609
		Connecting thread 1/8 NPT	For tubing O.D. 5/16"	QS-1/8-5/16-U	153608
		Connecting thread 1/8 NPT	For tubing O.D. 1/4"	QS-1/8-1/4-U	153605
		Connecting thread 1/2 NPT	For tubing O.D. 1/2"	QS-1/2-1/2-U	153615
Connecting thread 1/2 NPT		For tubing O.D. 5/8"	QS-1/2-5/8-U	190682	
Silencer					
	G Thread				
	-	Connecting thread G1/4		U-1/4	2316
	L	Connecting thread G1/2		U-1/2	2310
	K	Connecting thread G1/2		U-1/2-B	6844
	NPT Thread				
	-	Connecting thread 1/4 NPT		U-1/4-B-NPT	12639
K, L	Connecting thread 1/2 NPT		U-1/2-B-NPT	12741	
Blanking Plug					
	G Thread				
	-	Thread G1/8	10	B-1/8	3568
	-	Thread G1/4	10	B-1/4	3569
	NPT Thread				
-	Thread 1/4 NPT	1	B-1/4-NPT	31783	

Accessories

Mounting Components and Manuals

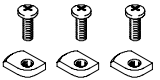
FESTO

Ordering Data					
Designation	Code	Description	Package Qty.	Type	Part No.
Mounting					
	-	For DIN rail, VTSA with fieldbus	3	CPX-CPA-BG-NRH	526032
	-	For DIN rail, VTSA with multi-pin plug	2	CPA-BG-NRH	173498
Wall Mounting					
	U	Mounting bracket	1	VAME-S6-10-W	539214

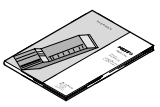
Ordering Data					
Designation	Code	Description	Language	Type	Part No.
User Manual					
	E	For type 44 valve terminal	English	P.BE-VTSA-44-EN	538923
	D		German	P.BE-VTSA-44-DE	538922
	S		Spanish	P.BE-VTSA-44-ES	538924
	F		French	P.BE-VTSA-44-FR	538925
	I		Italian	P.BE-VTSA-44-IT	538926
	V		Swedish	P.BE-VTSA-44-SV	538927

Compressed Air

Operate your equipment with unlubricated compressed air if possible. Festo valves and cylinders are designed for operation under normal use without any additional lubrication, yet still have a long service life. The quality of compressed air downstream of the compressor must correspond to that of unlubricated compressed air. If possible, do not operate all of your equipment with lubricated compressed air. The lubricators should, where possible, always be located downstream of the valves, directly upstream of the cylinders used.

Incorrect additional oil and too high an oil content in the compressed air reduces the service life of the valve terminal. Use Festo special oil OFSW-32, P/N 152811 (1 liter) (as specified in DIN 51524-HLP32; basic oil viscosity 32 cSt at 40°C).

Biodegradable Oils

When using bio-oils (oils which are based upon synthetic or native ester, e.g. rapeseed oil methyl ester), the maximum residual oil content of 0.1 mg/m³ must not be exceeded (see ISO 8573-1 Class 4).

Mineral Oils

When using mineral oils (e.g. HLP oils to DIN 51524, parts 1 to 3) or similar oils based on poly-alpha-olefins (PAO), the maximum residual oil content of 5 mg/m³ must not be exceeded (see ISO 8573-1 Class 4). A higher residual oil content irrespective of the compressor oil cannot be permitted, as the basic lubricant would be washed away over time.

Festo Product Range

Integrated Systems



- Design, documentation, assembly/testing
- Single and multi-axis linear and rotary systems
- Stepper controls, servo pneumatic and servo electric systems

Control Cabinets



- Design, documentation, assembly/testing
- Cabinets are designed, manufactured, assembled, and tested per NEMA, UL, and IEC standards
- Standard and stainless steel enclosures

Pneumatic Actuators and Grippers



- ISO and NFPA cylinders
- Linear and rotary actuators
- Standard, precision, and micro grippers plus accessories

Electromechanical Actuators



- Belt and ball screw driven linear actuators
- High accuracy and repeatability
- High rigidity and speed

Pneumatic Valves and Valve Manifolds



- Valves**
- In-line/subbase directional control valves
- OSHA compliant lockout valves
- Proportional valves
- Valve Manifolds**
- Direct, multi-pin, and fieldbus manifolds

Sensors and Control Technology



- Inductive, optical, mechanical, pressure and vacuum sensors
- PLCs and IPCs
- Remote access panels [HMI]
- Counters, timers and gauges

Air Preparation



- Filters
- Regulators
- Lubricators
- Dryers
- Combination units

Vacuum Components



- Vacuum generators
- Suction cups and suction grippers
- A variety of suction cup types and materials are available

Fittings and Tubing

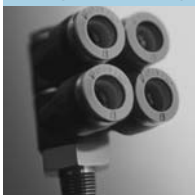

- Inch/metric fittings, hybrid fittings, and flow controls
- Inch/metric tubing (various materials and colors)

Industry Specific Solutions



- Cylinders, manifolds, tubing and fittings for use in washdown environments
- Linear/rotary actuators with and without a process valve; diaphragm valves, Namur valves

For more information about the entire Festo product range, including technical specifications, CAD models, product selection software, and access to our on-line store, visit us at www.festo.com/us.

Conversion Factors

The conversion table below includes the units most commonly used for designing a system. They are given to enable the user to make necessary calculations.

Length or Distance

$$\text{m} \rightarrow \text{ft} = \times 3.281$$

$$\text{mm} \rightarrow \text{inch} = \div 25.4$$

Volume

$$\text{cm}^3 \rightarrow \text{in}^3 = \times 0.061$$

Mass

$$\text{g} \rightarrow \text{lb} = \times 0.002$$

$$\text{kg} \rightarrow \text{lb} = \times 2.2046$$

Pressure

$$\text{bar} \rightarrow \text{psi} = \times 14.7$$

Temperature

$$\text{C}^\circ \rightarrow \text{F}^\circ = \times [1.8] + 32$$

Flow

$$\text{l/min} \rightarrow \text{Cv} = \times 0.001$$

$$\text{l/min} \rightarrow \text{scfm} = \times 0.0353$$

Force

$$\text{N} \rightarrow \text{lbf} = \times 0.2248$$

$$\text{kgf} \rightarrow \text{N} = \times 9.80665$$

Moment

$$\text{Nm} \rightarrow \text{in-lb} = \times 8.8507$$

$$\text{Nm} \rightarrow \text{ft-lb} = \times 0.7376$$

Moment of Inertia

$$\text{kg}\cdot\text{cm}^2 \rightarrow \text{lb}\cdot\text{in}^2 = \times 0.3417$$

$$\text{kg}\cdot\text{m} \rightarrow \text{lb}\cdot\text{ft} = \times 7.233$$

$$\text{kg}\cdot\text{m}^2 \rightarrow \text{oz}\cdot\text{in}^2 = \times 5.4675$$

© Copyright 2006, Festo Corporation

While every effort is made to ensure that all dimensions and specifications are correct, any printing errors not rectified are outside the control of Festo, who cannot be held responsible for the same. For Liability and Warranty conditions, refer to our standard "Conditions of Sale", available on request from your local Festo office.

All rights reserved. No part of this publication may be reproduced or transmitted in any form or by any means, electronic, mechanical, photocopying or otherwise, without the prior written permission of Festo. All technical data subject to change according to technical update.

Festo North America

United States

For ordering and product assistance, or to find your nearest Festo Distributor in the USA, contact us via:

Phone: 1.800.99.FESTO

Fax: 1.800.96.FESTO

Email: customerservice@us.festo.com

www.festo.com/us

Customer Resource Center

502 Earth City Expressway
Suite 125
Earth City, MO 63045
Call Toll-free: 1.800.993.3786
Fax Toll-free: 1.800.963.3786

Headquarters

Festo Corporation
395 Moreland Road
P.O. Box 18023
Hauppauge, NY 11788

Sales Offices

Boston

120 Presidential Way
Suite 330
Woburn, MA 01801

Charlotte

4301-S Stuart Andrew Blvd.
Charlotte, NC 28217

Chicago

1441 East Business Center Drive
Mt. Prospect, IL 60056

Dallas

1825 Lakeway Drive
Suite 600
Lewisville, TX 75057

Detroit

1228 Kirts Blvd.
Suite 400
Troy, MI 48084

New York

395 Moreland Road
Hauppauge, NY 11788

Silicon Valley

2800 Collier Canyon Road
Livermore, CA 94550

Design and Manufacturing Facilities



East: 395 Moreland Road, Hauppauge, NY 11788



Central: 1441 East Business Center Drive, Mt. Prospect, IL 60056



West: 2800 Collier Canyon Road, Livermore, CA 94550

Mexico

Headquarters

Festo Pneumatic, S.A.
Av. Ceylán 3
Col. Tequesquahuac
54020 Tlalnepantla
Edo. de México
Phone: 011 52 [55] 53 21 66 00
Fax: 011 52 [55] 53 21 66 65
Email: festo.mexico@mx.festo.com
www.festo.com/mx



Canada

Headquarters

Festo Inc.
5300 Explorer Drive
Mississauga, Ontario L4W 5G4
Phone: 1.905.624.9000
Fax: 1.905.624.9001
Email: info_ca@festo.com
www.festo.com/ca



Festo Worldwide

Argentina Australia Austria Belarus Belgium Brazil Bulgaria Canada Chile China Colombia Croatia Czech Republic Denmark Estonia
Finland France Germany Great Britain Greece Hong Kong Hungary India Indonesia Iran Ireland Israel Italy Japan Korea Latvia
Lithuania Malaysia Mexico Netherlands New Zealand Norway Peru Philippines Poland Romania Russia Serbia and Montenegro Singapore
Slovak Republic Slovenia South Africa Spain Sweden Switzerland Taiwan Thailand Turkey Ukraine United States Venezuela

www.festo.com