

The SWC Series Swing Check Valves

- Large Diameter Pivot Shaft Construction
- Meets AWWA C-508-01 Standards (Full Waterway)
- Accepts Air Cushion and Oil Control Devices



Crispin
Since 1905

Crispin Multiplex Manufacturing Co. • 600 Fowler Avenue • Berwick, PA 18603 • 1-800-AIR-VALV
T: (570) 752-4524 • F: (570) 752-4962 • www.crispinvalve.com • sales@crispinvalve.com



SWC SERIES

Swing Check Valve

Swing Check Valve

The "SWC" series Swing Check Valve from Crispin Valve provides users of Crispin products with a AWWA C-508-01 solution for more arduous Check Valve applications including sewage and slurry. The "SWC" design takes over when the "RF" Rubber Flapper Series and the "TD" Tilting Disc Series are not optimal.

Designed with a heavy-duty pivot shaft, the "SWC" can accept both Air Cushion as well as Oil Control devices. The substantial shaft diameter is ideal for those difficult applications where back pressure can reach higher values quickly.

In order to reduce hammer and protect the system itself, these back pressures need to be "absorbed" by a cushion. This requirement generates a larger amount of torque on the pivot shaft that commodity type valves cannot handle.

Seating

Once pump pressure exceeds the back pressure on the down-stream side of the valve disc, the Swing Check Valve moves the disc out of the flow by displacing the seat disc to the upper portion of the unit. This creates full flow through the unit for both water and sewage.

Crispin "SWC" valves are standard with Rubber Disc Seats and O-Ring Seats. These "no-cost" upgrades make the valve ideal for aggressive water and sewage applications found in many areas.

Upon pump shut down, the disc will stroke closed when velocity begins to slow and stop. With the incorporation of a rubberized disc face, the resultant drop tight seating will protect the system from costly drain-back.

Swing Check Design Features

• Body Seat

Many designs incorporate a threaded in seat. Especially in larger sizes, replacement of this seat is almost impossible, let alone while the valve remains in-line.

In the Crispin "SWC" Series, the body seat is held in place by stainless steel set screws. Both the Body Seat and the Disc Seat can be easily accessed and changed by removing the valve cover, while the valve is in line.

• O-Ring Design

Most Swing Check Valve designs still rely on the use of packing or "stuffing boxes." The "SWC" Series uses o-rings that are easily replaceable and readily available.

• Pivot Shaft

Larger valve diameters require a larger body and disc arm, and standard designs can't incorporate a diameter large enough to use an Oil Control device.

Even with lighter duty valves that use Air Cushions, any back pressure outside the normal operating range can cause severe damage and wear. The diameter of the "SWC" Series pivot shaft sets it apart from commodity type swing check valves.

Full Waterway Flow Area

With a flow area that is greater than or equal to the



12" air-cushioned Swing Checks are shown at a recent Crispin installation. The air valves in the photo are also from Crispin.



SWC SERIES

Swing Check Valve

nominal valve size, the “SWC” Swing Check Valve has a lower head loss characteristic than a Silent Check valve. It can also be mounted both horizontally and vertically on the project’s pipeline.

• Disc

Most standard designs hold the disc in place via a single connection to the disc arm, which can cause vibration. The Crispin “SWC” Disc Arm connects the pivot shaft to the Disc itself. Pinned to the arm in two places, the disc won’t tilt or vibrate on the arm during operation.

• Through Shaft

Internalizing the shaft on one end can increase wear of the unit dramatically. On the Crispin “SWC” series, the Pivot Shaft extends through both sides of the body, allowing it to be changed to either side of the unit, and making installation more manageable.

• Dashpots and Cushions

Available as options, Dashpots and Cushions are designed to give the customer control over the opening and closing speeds of the valve, which can be very helpful in eliminating down line surges and valve wear.

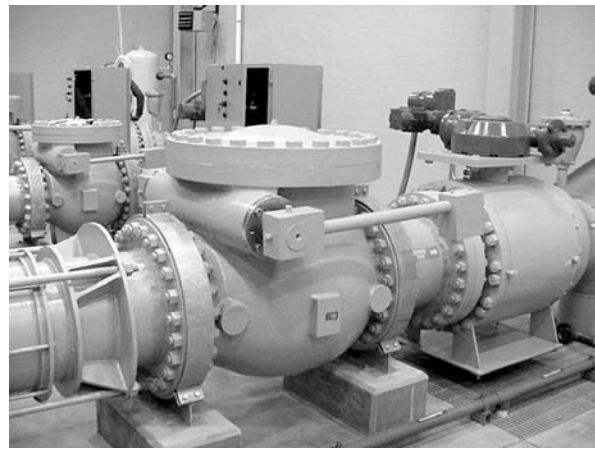

Standard with Rubber Disc Seats and Stainless Steel Body Seats, Crispin Swing Checks are ideal for aggressive water and sewage applications.

Dashpots are field adjustable and available in both side and bottom mountings. Side mountings can be added later. Both designs utilize a high quality hydraulic cylinder to impact disc movement. Air Cushions can also be added to the unit’s exterior and offer a simple, cost effective way to absorb the slamming common to most swing check units. ■

Head Loss Characteristics of Crispin Swing Check Valves

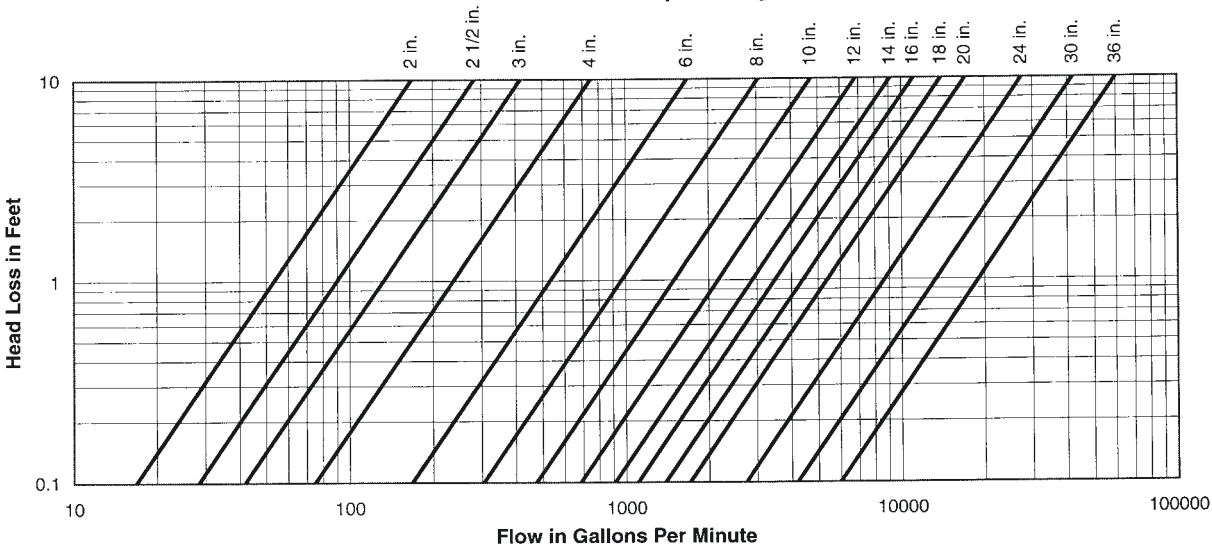



Swing Check Valve

Swing Check Valve

Swing Check Design Features

SWC SERIES

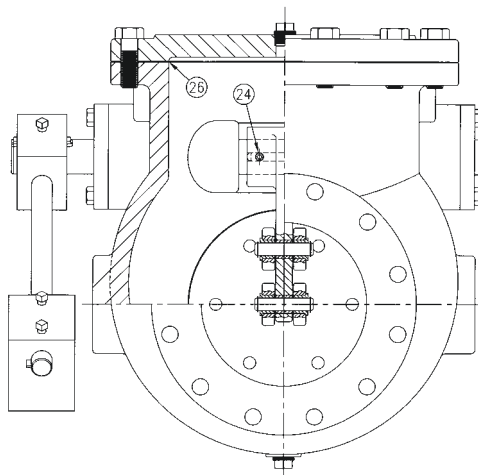
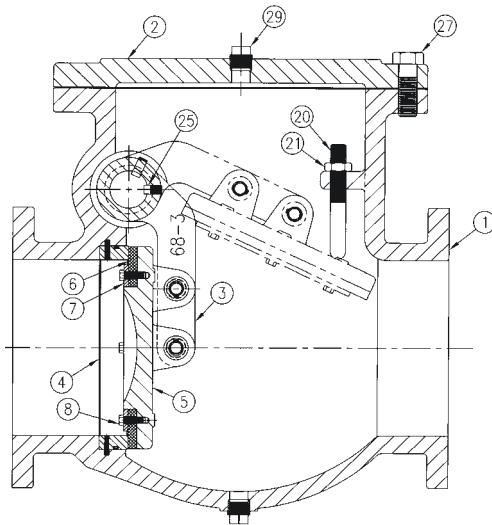
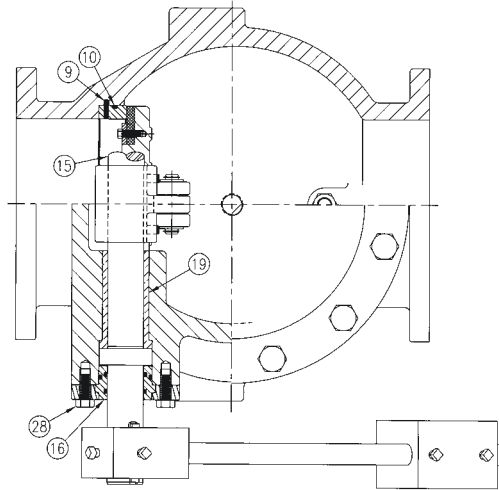

SWC Series Parts List

ITEM	DESCRIPTION	MATERIAL
1	BODY	A126 CL. B CAST IRON
2	COVER	A126 CL. B CAST IRON
3	DISC ARM	A536 GR.65-45-12 DUCTILE IRON
4	BODY SEAT	A240 TYPE 316 S/S
5	DISC	A536 GR.65-45-12 DUCTILE IRON
6	DISC SEAT	D2000 BUNA-N RUBBER
7	SEAT RETAINER	A240 TYPE 316 S/S
8	SEAT RET. BOLT	A193 TYPE 31/6 S/S
9	SEAT RETAINER	A193 TYPE 316 S/S
	SET SCREW	
10	O-RING	D2000 BUNA-N RUBBER
11	DISC PIN	A276 TYPE 316 S/S
12	DISC ARM SLEEVE	A276 TYPE 316 S/S
13	RETAINING RING	A564 17-7PH S/S
14	DISC SLEEVE	A276 TYPE 316 S/S
15	PIVOT SHAFT	A582 TYPE 303/A564 TYPE 17-4PH
16	R.H. END CAP BUSHING	B505, UNS C95400, AL-BRONZE
17	L.H. END CAP BUSHING	B505, UNS C95400, AL-BRONZE
18	END CAP FLANGE	A126 CL. B CAST IRON
19	PIVOT BUSHING	B505, UNS C95400, AL-BRONZE
20	DISC STOP	A193 TYPE 316 S/S
21	DISC STOP NUT	A194 TYPE 316 S/S
22	O-RING	D2000 BUNA-N RUBBER
23	O-RING	D2000 BUNA-N RUBBER
24	DISC SET SCREW	A193 TYPE 316 S/S
25	PIVOT KEY	A276 TYPE 316 S/S
26	COVER GASKET	KLINGER-SIL C-4401
27	COVER BOLT	A193 TYPE 316 S/S
28	END CAP BOLT	A193 TYPE 316 S/S
29	PLUG	A126 CL. B CAST IRON
32	LEVER ASSEMBLY	STEEL

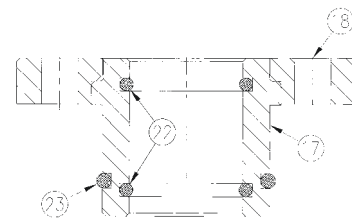

Diagram Reference

Flange Diameter
 Flange Thickness
 Bolt Circle Diameter
 Number of Bolts
 Bolt Hole Diameter

Dimension D
 Dimension E
 Dimension F
 Dimension G
 Dimension H

Swing Check Valve



Swing Check Valve

“SWC” Series Dimensions (LW—Lever and Weight*)

SIZE	MODEL # (125, 250)	A	B	C	D	E	F	BOLT SIZE	# OF BOLTS	APPROX. WEIGHT
2	SWC21-LW	8.00	16.50	18.25	6.00	0.625	4.750	0.625	4	145
2	SWC22-LW	8.00	16.50	18.25	6.50	0.75	5.000	0.625	8	153
2.5	SWC251-LW	10.00	17.50	18.50	7.00	0.688	5.500	0.625	4	147
2.5	SWC252-LW	10.00	17.50	18.50	7.50	1.000	5.875	0.750	8	147
3	SWC31-LW	11.00	17.50	15.50	7.50	0.938	6.000	0.625	4	150
3	SWC32-LW	11.00	17.50	15.50	8.25	1.125	6.625	0.750	8	160
4	SWC41-LW	13.00	18.00	20.25	9.00	0.938	7.500	0.625	8	200
4	SWC42-LW	13.00	18.00	20.25	10.00	1.250	7.875	0.750	8	215
6	SWC61-LW	17.50	20.25	25.25	11.00	1.000	9.500	0.750	8	300
6	SWC62-LW	17.50	20.25	25.25	12.50	1.438	10.625	0.750	12	343
8	SWC81-LW	19.50	22.25	25.50	13.50	1.125	11.750	0.625	8	400
8	SWC82-LW	19.50	22.25	25.50	15.00	1.625	13.000	0.875	12	463
10	SWC101-LW	24.50	28.50	30.75	16.00	1.188	14.250	0.875	12	550
10	SWC102-LW	24.50	28.50	30.75	17.50	1.875	15.250	1.000	16	654
12	SWC121-LW	28.00	35.75	33.25	19.00	1.250	17.000	0.875	12	1100
12	SWC122-LW	28.00	35.75	33.25	20.50	2.000	17.750	1.125	16	1206
14	SWC141-LW	31.00	27.50	40.00	21.00	1.375	18.750	1.000	12	1650
14	SWC142-LW	31.00	27.50	40.00	23.00	2.125	20.250	1.125	20	1827
16	SWC161-LW	36.00	43.25	41.75	23.50	1.438	21.250	1.000	16	1995
16	SWC162-LW	36.00	43.25	41.75	25.50	2.250	22.500	1.250	20	2415
18	SWC181-LW	40.00	45.75	46.00	25.00	1.563	22.750	1.125	16	2400
18	SWC182-LW	40.00	45.75	46.00	28.00	2.375	24.750	1.250	24	2760
20	SWC201-LW	40.00	50.25	49.75	27.50	1.688	25.000	1.250	20	2800
20	SWC202-LW	40.00	50.25	49.75	30.50	2.500	27.000	1.125	24	3135
24	SWC241-LW	48.00	55.75	53.25	32.00	1.875	29.500	1.250	20	6200
24	SWC242-LW	48.00	55.75	53.25	36.00	2.750	32.000	1.500	24	6875
30	SWC301-LW	56.00	68.00	62.25	38.75	2.125	36.000	1.250	28	8500
30	SWC302-LW	56.00	68.00	62.25	43.00	3.000	39.250	1.750	28	9480
36	SWC361-LW	63.00	80.00	68.25	46.00	2.375	42.750	1.500	32	14000
36	SWC362-LW	63.00	80.00	68.25	50.00	3.375	46.000	2.000	32	15055

SWC SERIES

* Consult Factory for sizes over 36". Bypass piping is available on valve sizes 14" and larger.

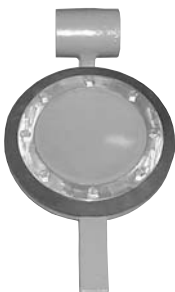

Pump side (left) view of the Swing Check's ductile iron disc arm, resilient disc seat and stainless steel seat retaining ring in the bottom dashpot configuration.



Downstream side view of the Swing Check's disc arm.



Swing Check Valve

Swing Check Valve

“SWC-AC” Series with Side Air Cushion

SWC SERIES

An external side mounted Air Cushion can be added to the standard Lever/Weight or Lever/Spring Unit to help reduce slamming of the valve. Easily adjustable and fully enclosed, the Bronze cylinder allows unrestricted opening and cushioned closure of the valve stroke. ■

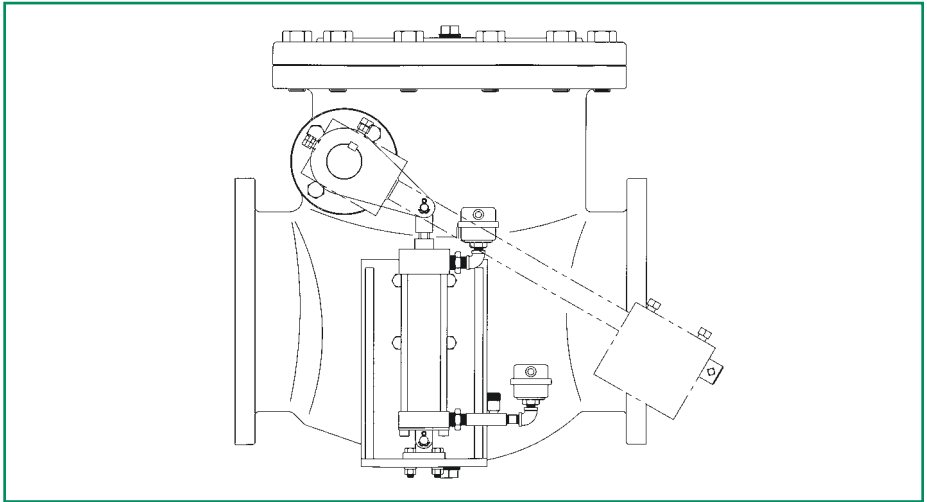

Swing Check Valve—Air Cushioned, Side Mounted

Available Sizes:	3"	4"	6"	8"	10"	12"	14"	16"	18"	20"	24"	30"	36"
# of Levers & Weights:	1	1	1	1	1	1	1	1	1	1	1	1	2
# of Cylinders:	1	1	1	1	1	1	1	1	1	1	1	1	2

“SWC-BD” Series with Bottom Oil Control (Dashpot)

This dashpot incorporates a rounded end shaft that projects into the valve, but not through the seat area. It is not physically attached to the disc itself. It therefore cannot control the rate at which the valve opens, but is designed to control the last 10% of the closing stroke.

Upon closure, the disc strikes the rounded end rod which is connected to the piston in the hydraulic cylinder. Oil in the cylinder is displaced into the pressurized accumulating tank. The rate at which this oil is displaced is the rate at which the valve closes during that last 10% of movement. This oil displacement is adjustable through the use of a needle valve. After closure, when the valve reopens, the pressurized accumulator is able to push the rod back into position, making it ready for the next closing cycle. ■

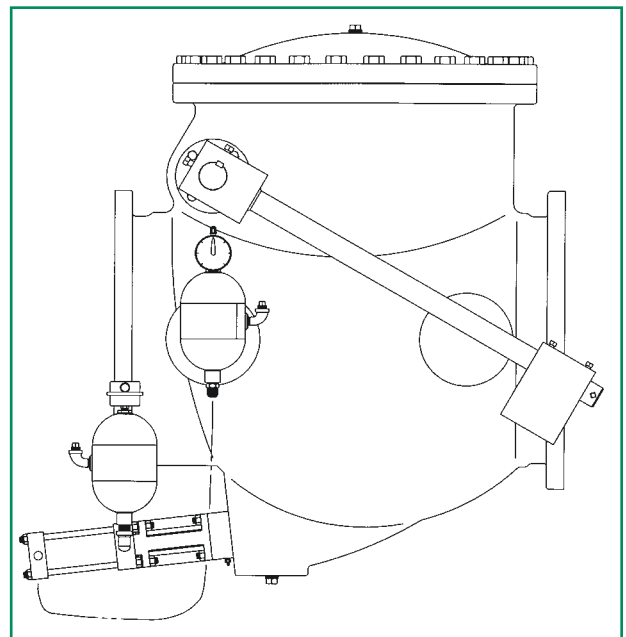

Swing Check Valve—Oil Cushioned, Bottom Buffer

Available Sizes:	6"	8"	10"	12"	14"	16"	18"	20"	24"	30"	36"
# of Levers & Weights:	1	1	1	1	2	2	2	2	2	2	2
# of Cylinders:	1	1	1	1	1	1	1	1	1	1	1



SWC SERIES

Swing Check Valve

“SWC-OC” Series with Side Oil Control (Dashpot)

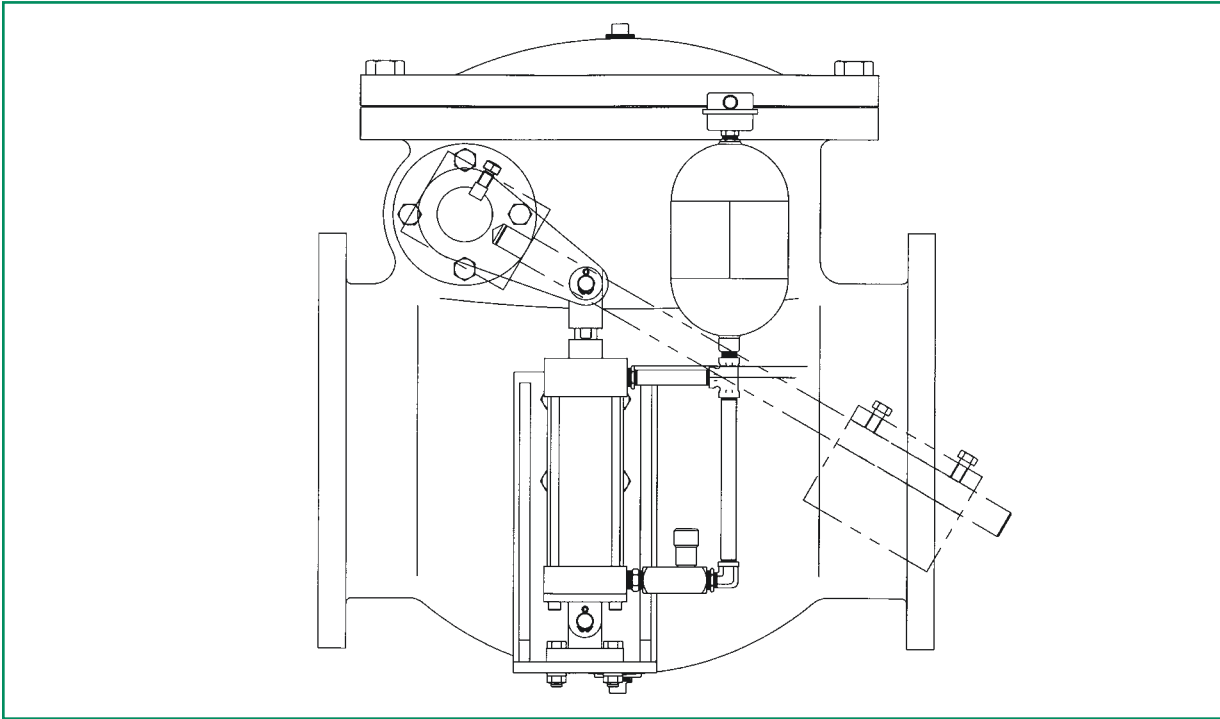

The operating principle of this mechanism is essentially the same as the bottom mounted unit except that the hydraulic cylinder is connected directly to the pivot shaft via a clevis, link, and rod eye. This is done so that both the opening and closing of the valve may be controlled. When the valve opens, oil is displaced into the pressurized accumulator and can be adjusted as above. This controls the full stroke of opening.

During closure, however, the design of the two chamber cylinder allows closing to be broken into two stages. The first stage of the closing stroke is able to be much quicker due to the pressurized air cushion in the accumulator. This air expands and forces the oil back into the chamber faster, creating pressure against the piston and closing the valve quicker. The actual closure rate of this first stage is achieved by the use of a needle valve.

The second, final stage of closure is controlled by a small internal valve and an oil flow channel that controls the last portion of the oil flow into the accumulator. Adjustment of this valve gives the disc a final “cushion” at the end of the closing stroke.

This option is also available with the addition of a **Timing Valve**. The optional timing valve allows the valve to close to an adjustable degree rapidly on pump shut off. This option provides a means of reducing the closing time, which is key to containing column reversal. This is accomplished all without the “slamming” associated with non-cushioned valves. ■

Swing Check Valve—Oil Cushioned, Side Mounted

Available Sizes:	3"	4"	6"	8"	10"	12"	14"	16"	18"	20"
# of Levers & Weights:	1	1	1	1	2	2	2	2	2	2
# of Cylinders:	1	1	1	1	2	2	2	2	2	2

Two Swing Check Valves From Crispin



SWC & SWL SERIES



With a flow area that is greater than or equal to the nominal valve size, Crispin Swing Check Valves have a lower head loss characteristic than Silent Check Valves.

They can also be mounted both horizontally and vertically.

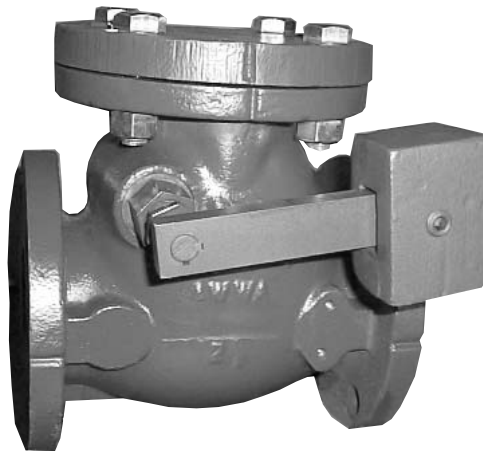

An ideal solution for standard check valve applications, the "SWL" from Crispin is designed as a cost-effective companion to our "SWC" valve.

SWC SERIES

- Large Diameter Pivot Shaft Construction
- Accepts Air Cushion and Oil Control Devices
- Meets AWWA C-508-01 Standards
- O-Ring Design
- Available in Class 125 and 250
- Stainless Steel Available
- Optional Dashpots and Cushions
- Ideal for Sewage and Slurry
- Sizes 2" thru 36"

SWL SERIES

- Cost-Effective for Standard Applications
- Standard AWWA-C-508-01 Compliant Shaft
- Accepts Air Cushions
- 316 Stainless Steel Seat Available
- Lever & Weight or Lever & Spring Configurations available
- Available in Class 125 only
- Meets AWWA C-508-01 Standards
- Sizes 2" thru 14"