



GC SERIES

Globe Style Silent Check Valve

Globe Style Silent Check Valve

Service Applications

Municipal Water Systems



Industrial Class HVAC-Liquid Service



Industrial Piping Systems



Irrigation Systems

Pressure/Temperature Rating

**Maximum Temperature Rating:
150°F (65°C)**



**Pressure Class:
ANSI B16.1
B.S. 4504 DIN PN 10
PN 16 & PN 25**

Sizes

**Available in sizes
2 1/2" to 36"**

NOTE: Crispin Globe Style Check Valves are intended for liquid service only. Please consult factory when applications other than liquid are required.

Globe Style Check Valves are designed to close before the pump stops completely. This prevents flow reversal, which eliminates water hammer and system surges associated with valve closure. Fully automatic, spring-loaded and double-guided, the valve opens as the pump starts, and closes just prior to flow reversal upon pump outage. With a standard cast iron body, bronze seat, disc and bushing, and a stainless steel spring, all internal parts of the Globe Style Check Valve are field replaceable for ease of maintenance. In addition, the Globe Style Check Valve is designed so that a butterfly valve may be used downstream without the use of a space flange or spool piece. This feature is available in sizes through 10".

Resilient seats are highly recommended for potable water or drip tight applications.

Standard and Optional Materials

NAME	MATERIAL (STANDARD)	MATERIAL (OPTIONAL)
BODY	CAST IRON ASTM A126 CLASS B	DUCTILE IRON ASTM A536 GR65-45-12
DISC	BRONZE ASTM B62	STAINLESS STEEL ASTM A743, CF8M, T316
SEAT RING*	BRONZE ASTM B62	STAINLESS STEEL ASTM A743 CF8M, T316
<small>*BUNA-N or VITON resilient seating available.</small>		
SPRING	S/S ASTM A313	S/S ASTM T316
BUSHING	BRONZE ASTM B584	SS/S ASTM A276, T316
SCREWS	STAINLESS STEEL 18-8	STAINLESS STEEL T316

u Consult factory for optional construction materials.

Pressure Testing

	CLASS 125	CLASS 250
2-1/2" (65mm) - 12" (300mm)		
NON SHOCK GAGE PRESSURE	200 psi (13.6 BAR)	400 psi (27.2 BAR)
SHELL TEST PRESSURE	300 psi (20.4 BAR)	750 psi (51.0 BAR)
SEAT TEST PRESSURE	300 psi (20.4 BAR)	400 psi (27.2 BAR)
14" (350mm) - 36" (400mm)		
NON SHOCK GAGE PRESSURE	150 psi (10.2 BAR)	300 psi (20.4 BAR)
SHELL TEST PRESSURE	230 psi (15.6 BAR)	450 psi (30.6 BAR)
SEAT TEST PRESSURE	230 psi (15.6 BAR)	300 psi (20.4 BAR)

Globe Style Silent Check Valve



Globe Style Silent Check Valve

Valve Dimensions

MODEL				ANSI CLASS FLANGE	VALVE SIZE in. (mm)	FACE TO FACE (B) in. (mm)	MAX. DIA. in. (mm)	WEIGHT lb. (kg.)	# OF BOLTS	BOLT SIZE in. (mm)
STD TRIM SEAT	STD TRIM RESILIENT SEAT	S/S TRIM	S/S TRIM RESILIENT SEAT							
GC251	GC251.R	GC251.2	GC251.2R	125	2 1/2 (65)	5 1/2 (140)	7 (178)	24 (11)	4	5/8 (16) x 2 1/2 (63.5)
GC252	GC252.R	GC252.2	GC252.2R	250	2 1/2 (65)	5 1/2 (140)	7 1/2 (190.5)	30 (14)	8	3/4 (20) x 3 1/4 (82.5)
GC31	GC31.R	GC31.2	GC31.2R	125	3 (80)	6 (152.5)	7 1/2 (190.5)	30 (14)	4	5/8 (16) x 3 (76)
GC32	GC32.R	GC32.2	GC32.2R	250	3 (80)	6 (152.5)	8 1/4 (209.5)	38 (17)	8	3/4 (20) x 3 1/2 (89)
GC41	GC41.R	GC41.2	GC41.2R	125	4 (100)	7 1/4 (184)	9 (229)	45 (21)	8	5/8 (16) x 3 (76)
GC42	GC42.R	GC42.2	GC42.2R	250	4 (100)	7 1/4 (184)	10 (254)	61 (28)	8	3/4 (20) x 3 3/4 (95)
GC51	GC51.R	GC51.2	GC51.2R	125	5 (125)	8 1/2 (216)	10 (254)	55 (25)	8	3/4 (20) x 3 (76)
GC52	GC52.R	GC52.2	GC52.2R	250	5 (125)	8 1/2 (216)	11 (279.5)	78 (36)	8	3/4 (20) x 4 (101.5)
GC61	GC61.R	GC61.2	GC61.2R	125	6 (150)	9 3/4 (248)	11 (279.5)	80 (37)	8	3/4 (20) x 3 1/4 (82.5)
GC62	GC62.R	GC62.2	GC62.2R	250	6 (150)	9 3/4 (248)	12 1/2 (317.5)	110 (50)	12	3/4 (20) x 4 (101.5)
GC81	GC81.R	GC81.2	GC81.2R	125	8 (200)	12 1/2 (317.5)	13 1/2 (343)	139 (64)	8	3/4 (20) x 3 1/2 (89)
GC82	GC82.R	GC82.2	GC82.2R	250	8 (200)	12 1/2 (317.5)	15 (381)	181 (83)	12	7/8 (24) x 4 1/2 (114)
GC101	GC101.R	GC101.2	GC101.2R	125	10 (250)	15 1/2 (394)	16 (406.5)	234 (107)	12	7/8 (24) x 3 3/4 (95)
GC102	GC102.R	GC102.2	GC102.2R	250	10 (250)	15 1/2 (394)	17 1/2 (444.5)	239 (109)	16	1 (27) x 5 1/4 (133.5)
GC121	GC121.R	GC121.2	GC121.2R	125	12 (300)	14 1/4 (362)	19 (482.5)	335 (152)	12	7/8 (24) x 3 3/4 (95)
GC122	GC122.R	GC122.2	GC122.2R	250	12 (300)	14 1/4 (362)	20 1/2 (521)	417 (192)	16	1 1/8 (28) x 5 1/2 (140)
GC141	GC141.R	GC141.2	GC141.2R	125	14 (350)	15 3/4 (400)	21 (533.5)	380 (175)	12	1 (27) x 4 1/4 (105)
GC142	GC142.R	GC142.2	GC142.2R	250	14 (350)	15 3/4 (400)	23 (561)	511 (230)	20	1 1/8 (28) x 6 (150)
GC161	GC161.R	GC161.2	GC161.2R	125	16 (400)	17 5/8 (448)	23 1/2 (575)	501 (237)	16	1 (27) x 4 1/2 (110)
GC162	GC162.R	GC162.2	GC162.2R	250	16 (400)	17 5/8 (448)	25 1/2 (625)	697 (316)	20	1 1/4 (31) x 6 1/4 (155)
GC181	GC181.R	GC181.2	GC181.2R	125	18 (450)	18 3/4 (460)	25 (610)	529 (240)	16	1 1/8 (30) x 4 3/4 (115)
GC182	GC182.R	GC182.2	GC182.2R	250	18 (450)	18 3/4 (460)	28 (685)	725 (329)	24	1 1/4 (31) x 6 1/2 (160)
GC 201	GC201.R	GC201.2	GC201.2R	125	20 (490)	20 5/8 (503)	31 1/4 (763)	890 (405)	20	1 1/4 (31) x 5 (122)
GC 202	GC202.R	GC202.2	GC202.2R	250	20 (490)	20 5/8 (503)	31 1/4 (763)	1150 (522)	24	1 1/4 (31) x 6 3/4 (165)
GC241	GC241.R	GC241.2	GC241.2R	125	24 (586)	24 (586)	37 1/4 (1290)	1220 (554)	20	1 1/4 (31) x 5 1/2 (140)
GC242	GC242.R	GC242.2	GC242.2R	250	24 (586)	24 (586)	37 1/4 (1290)	1650 (759)	24	1 1/2 (37) X 7 1/2 (183)

* Please contact the factory for information on additional sizes up to 36."

GC SERIES

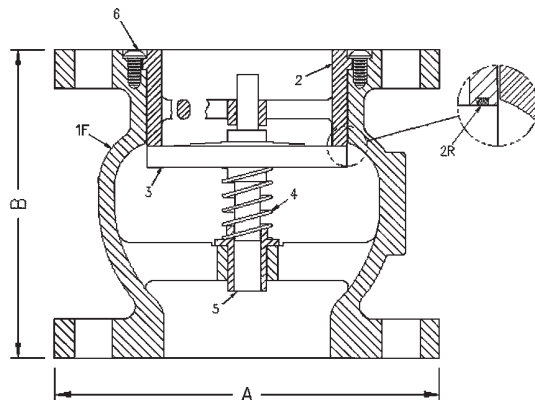

Parts List

ITEM	DESCRIPTION	MATERIAL (standard)
1	Body	Cast Iron
2*	Seat Ring	Bronze
3	Disc	Bronze
4	Spring	Stainless Steel
5	Bushing	Bronze
6	Screws	Stainless Steel

◆ Consult factory for optional construction materials.
*Resilient seating of BUNA-N or VITON available.
Materials and Prices Subject to Change Without Notice.



GC SERIES

Globe Style Silent Check Valve

Globe Style Silent Check Valve

Flow Velocity

These valves have a maximum recommended flow velocity of 10 feet per second. In addition, flow curves are based on the flow of clean water at an ambient temperature.

Valve Replacement

Existing swing check valves can easily be replaced with a Crispin Globe Style Check Valve. The replacement involves the addition of a spool piece to be bolted to the replacement valve. The entire assembly can be provided to conform to the existing valve's face-to-face dimension.

Line Placement

Preferred piping standards recommend placing check valves 5 to 10 pipe diameters from any turbulence producing devices (i.e. pumps, elbow, etc.). This installation recommendation should be followed to prevent increased valve wear or possible damage.

Head Loss Characteristics

Globe Style Check Valve Performance Curves

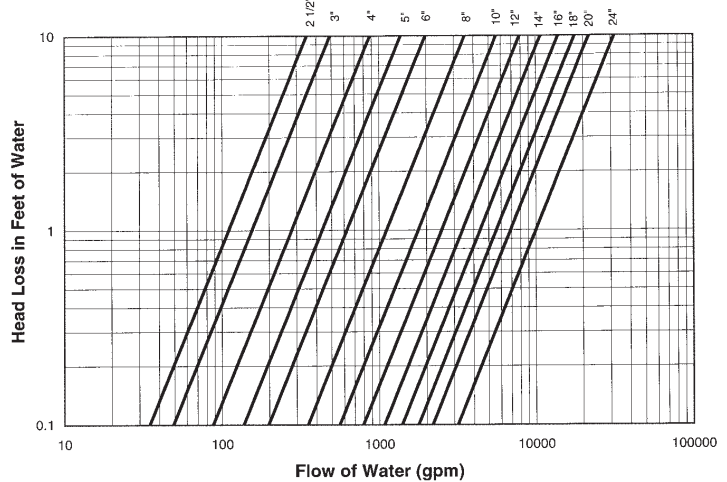

Special Maintenance Note:

The Globe Style Silent Check Valve should never be inspected by only removing the valve inlet flange piping. If this is done, seat damage to the valve or personal injury to the inspector may occur. If the valve must be serviced, it should be isolated and the line pressure relieved on both sides of the valve. For additional instructions, consult the Operation and Maintenance section of the Crispin Multiplex Manufacturing Company catalog.

These valves are intended for use on municipal water systems, or approved commercial and/or industrial applications only.

Order resilient seats for potable water or drip tight applications.

Additional Ordering Option:



The Globe Style Check Valve is designed so that a butterfly valve may be used downstream without the use of a space flange or spool piece.

Submittal Sheet for Crispin GC Series

2 1/2"–5" Globe Check Valve

Date: October, 2001



Specifications

The Silent Globe Check Valve(s) shall be fully automatic, spring loaded and double guided. The valve shall open as the pump starts, and close just prior to flow reversal upon pump outage.

The valve shall have a cast iron body, bronze seat, disc and bushing, and stainless steel spring. All internal parts shall be field replacable for east of maintenance.

The valve shall be model _____ as manufactured by Crispin-Multiplex Manufacturing Co., Crispin Valve Division, Berwick, PA.

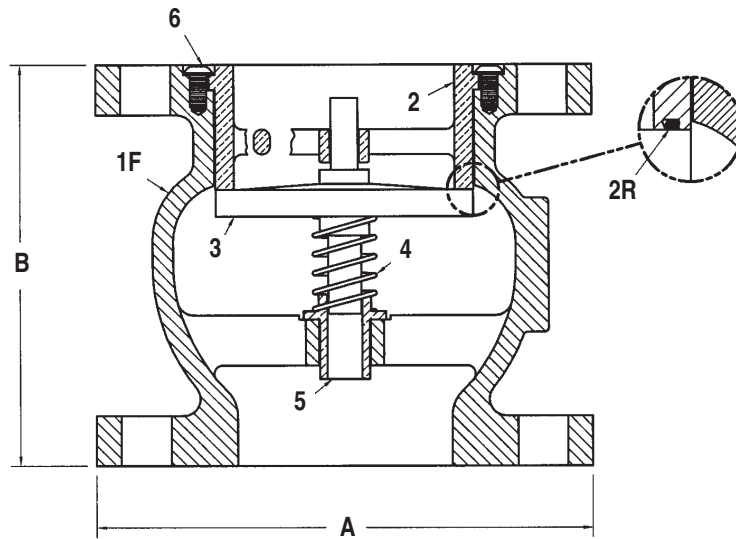

Size Specifications

MODEL	VALVE SIZE	A	B	WEIGHT
GC251	2 1/2" 125# FLG	7.00	5.50	24
GC252	2 1/2" 250 FLG	7.50	5.50	30
GC31	3" 125# FLG	7.50	6.00	30
GC32	3" 250# FLG	8.25	6.00	38
GC41	4" 125# FLG	9.00	7.25	45
GC42	4" 250# FLG	10.00	7.25	61
GC51	5" 125# FLG	10.00	8.50	55
GC52	5" 250# FLG	11.00	8.50	78

* Parts are interchangeable and optional at customer's request
For resilient seat, add .R to Model Number. Also available with stainless steel trim.

Parts List for Globe Check Valve

ITEM	DESCRIPTION	MATERIAL	ASTM
1	BODY	CAST IRON	A126 CL.B
*2	SEAT	CAST BRONZE	B62
*2R	RESILIENT SEAT	CAST BRONZE/BUNA-N RUBBER	B62/D2000
3	DISC	CAST BRONZE	B62
4	SPRING	STAINLESS STEEL	A313
5	BUSHING	BRONZE	B62
6	SCREW	STAINLESS STEEL	A193

SUBMITTAL SHEET FOR GC SERIES



Submittal Sheet for Crispin GC Series

6"-24" Globe Check Valve†

Date: October, 2001

Specifications

The Silent Globe Check Valve(s) shall be fully automatic, spring loaded and double guided. The valve shall open as the pump starts, and close just prior to flow reversal upon pump outage.

The valve shall have a cast iron body, bronze seat, disc and bushing, and stainless steel spring. All internal parts shall be field replaceable for ease of maintenance.

The valve shall be model _____ as manufactured by Crispin-Multiplex Manufacturing Co., Crispin Valve Division, Berwick, PA.

* Parts are interchangeable and optional at customer's request

For resilient seat, add .R to Model Number. For stainless steel trim, add .2 to model number.

† For sizes 24" thru 36", please contact the factory for additional information.

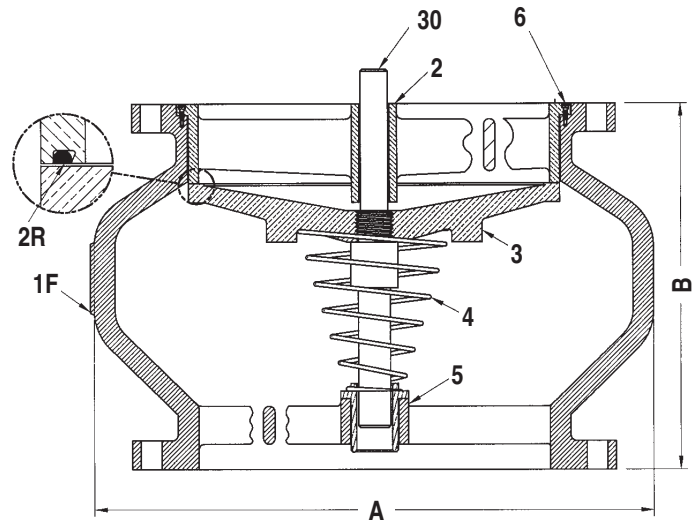

Size Specifications

MODEL	VALVE SIZE	A	B	WEIGHT
GC61	6" 125# FLG	11.00	9.75	80
GC62	6" 250# FLG	12.50	9.75	110
GC81	8" 125# FLG	13.50	12.50	139
GC82	8" 250# FLG	15.00	12.50	181
GC101	10" 125# FLG	16.00	15.50	234
GC102	10" 250# FLG	17.50	15.50	314
GC121	12" 125# FLG	19.00	14.25	335
GC122	12" 250# FLG	20.50	14.25	417
GC141	14" 125# FLG	21.00	15.75	380
GC142	14" 250# FLG	23.00	15.75	511
GC161	16" 125# FLG	23.50	17.75	501
GC162	16" 250# FLG	25.50	17.75	697
GC181	18" 125# FLG	25.00	18.75	529
GC182	18" 250# FLG	28.00	18.75	725
GC201	20" 125# FLG	31.25	20.75	860
GC202	20" 250# FLG	31.25	20.75	1150
GC241	24" 125# FLG	37.25	24.00	1220
GC242	24" 250# FLG	37.25	24.00	1650

Parts List for Globe Check Valve

ITEM	DESCRIPTION	MATERIAL	ASTM
1F	BODY	CAST IRON	A126 CL.B
*2	SEAT	CAST BRONZE	B62
*2R	RESILIENT SEAT	CAST BRONZE/BUNA-N RUBBER	B62/D2000
3	DISC	CAST BRONZE	B62
4	SPRING	STAINLESS STEEL	A313
5	BUSHING	BRONZE	B62
6	SCREW	STAINLESS STEEL	A193
30	SHAFT	BRONZE	B62

SUBMITTAL SHEET FOR GC SERIES