



FV SERIES

Foot Valves

Crispin Foot Valves

Valve Function

- Maintains pump prime upon pump outage

Features

- Resilient seat provides positive shut off
- Full flow area
- Stainless steel inlet screen
- Rugged construction for long life
- Available in sizes 2" to 36"



Installed on the pump suction, CRISPIN Foot Valves prevent the pump column from draining upon pump shutdown. Silent during operation and normally closed, the valve has a center guided disc with a Buna-N seat to provide a tight drip seal.

The minimum flow area, which is perpendicular to the direction of flow thru the valve, is equal to the pipe area. The inlet is fitted with a stainless steel screen over its opening to provide 3 to 4 times the area of the pipe.

Standard and Optional Materials

NAME	MATERIAL (Standard)	MATERIAL (Optional)
BODY	Cast Iron	Ductile Iron
SEAT	Bronze w/Buna-N Seat	316 Stainless Steel
DISC	Bronze	316 Stainless Steel
SCREEN	Stainless Steel	316 Stainless Steel
SCREEN RETAINING SCREWS	Stainless Steel	316 Stainless Steel
FLANGE	Cast Iron	Ductile Iron
BOLTS & NUTS	Galvanized Steel	Stainless Steel

*Consult factory for optional construction materials.

ANSI Class 125 Flanged Valves

MODEL	INLET SIZE	INLET CLASS	VALVE HEIGHT	O.D.	WEIGHT (LBS)
FV251	2 1/2"	125	8 3/4"	7 1/2"	31
FV31	3"	125	9 1/4"	8"	35
FV41	4"	125	10 1/2"	9 1/2"	47
FV51	5"	125	12 3/4"	10 1/2"	70
FV61	6"	125	16"	11 1/2"	100
FV81	8"	125	20 3/4"	14"	166
FV101	10"	125	25 3/4"	16 1/2"	276
FV121	12"	125	26 3/4"	19 1/2"	396
FV141	14"	125	29"	21 1/2"	465
FV161	16"	125	32 3/4"	23 1/2"	605
FV181	18"	125	28"	25"	725
FV201	20"	125	35"	31"	1059
FV241	24"	125	38 1/4"	37"	1600

*For 26" thru 36" dimensions, please consult the factory.

Submittal Sheet for Crispin FV Series

2"-4" Threaded Foot Valve

Date: October, 2001

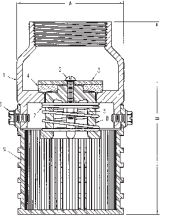

Specifications

Foot Valve(s) shall be installed on the pump suction to prevent the pump column from draining upon pump shutdown.

The valve(s) shall be silent operating and normally closed. A center guided disc with a Buna-N seat shall provide a drip tight seal. Minimum flow area perpendicular to the direction of flow thru the valve shall be equal to the pipe area. The inlet shall be fitted with a polypropylene screen with a clear opening adequate to provide 3 to 4 times the area of the pipe.

2"-4" threaded: The valve('s) materials of construction shall include a cast iron body, stainless steel spring, Delrin and stainless steel poppet, Nitrile seat, and polypropylene strainer. The pipe connection shall be _____" NPT.

The valve(s) shall be model _____ as manufactured by Crispin-Multiplex Manufacturing Co., Berwick, Pennsylvania.

Valve Parts List

ITEM	DESCRIPTION	MATERIAL	ASTM
1	BODY	CAST IRON	A126 CL.B
2	BOLT	STAINLESS STEEL	A193
3	DISC	STAINLESS STEEL	A240
4	SEAL	NITRILE	D2000
5	NUT	STAINLESS STEEL	A194
6	BOLT	STAINLESS STEEL	A193
7	SPRING	STAINLESS STEEL	A313
8	POPPET	DELIN	N/A
9	STRAINER	POLYPROPLYENE	N/A

Size Specifications

MODEL	INLET SIZE	OUTLET SIZE	A	B	WGHT.
FV20	2" NPT	2" NPT	3.50	6.25	3
FV30	3" NPT	3" NPT	5.50	9.25	8
FV40	4" NPT	4" NPT	6.75	11.25	15

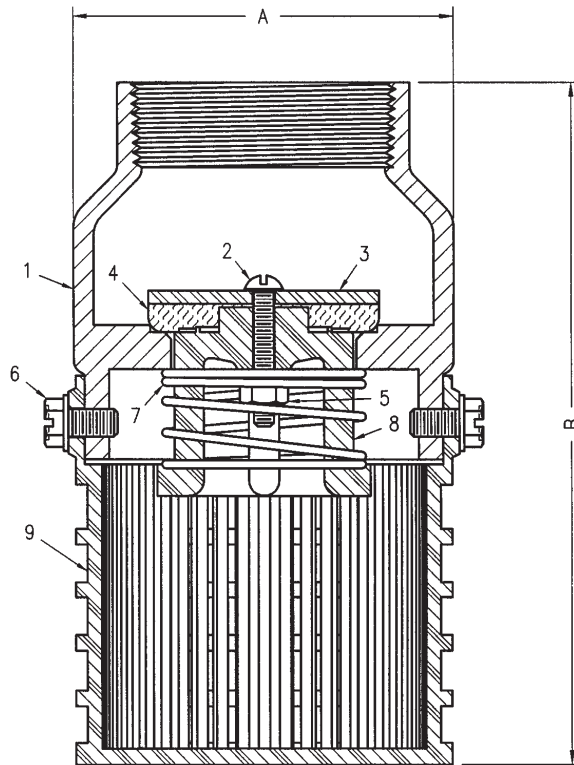

SUBMITTAL SHEET FOR FV SERIES



Submittal Sheet for Crispin FV Series

2 1/2"–5" Flanged Foot Valve

Drawing Date: October, 2001

Valve Parts List

ITEM	DESCRIPTION	MATERIAL	ASTM
1	BODY	CAST IRON	A126 CL.B
2R	RESILIENT SEAT	BRONZE/BUNA-N RUBBER	B62/D2000
3	DISC	BRONZE	B62
5	BUSHING	BRONZE	B62
6	SCREW	STAINLESS STEEL	A193
8	RETAINING RING	STAINLESS STEEL	A240
9	MOUNTING FLANGE	CAST IRON	A126 CL.B
11	BOLT	STAINLESS STEEL	A193
12	NUT	STAINLESS STEEL	A194
14	SCREEN	STAINLESS STEEL	A240
24	GASKET	ARMSTRONG N-8092	N/A
50	SCREEN RETAINING SCREW	STAINLESS STEEL	A193

Specifications

Foot Valve(s) shall be installed on the pump suction to prevent the pump column from draining upon pump shutdown.

The valve(s) shall be silent operating and normally closed. A center guided disc with a Buna-N seat shall provide a drip tight seal. Minimum flow area perpendicular to the direction of flow thru the valve shall be equal to the pipe area. The inlet shall be fitted with a stainless steel screen with a clear opening adequate to provide 3 to 4 times the area of the pipe.

2 1/2"-16" flanged: The valve(s) materials of construction shall include a cast iron body, bronze disc, bushing and seat ring with a Buna-N seal; and stainless steel inlet screen. The flanged pipe connection shall be AN SI Class 125.

The valve(s) shall be model _____ as manufactured by Crispin-Multiplex Manufacturing Co., Berwick, Pennsylvania.

Option: Internal materials of construction will include stainless steel disc, seat ring, and bushing.

Size Specifications

MODEL	INLET SIZE	OUTLET SIZE	A	B	WGHT.
FV251	2 1/2" 125# FLG	2 1/2" 125# FLG	7.50	8.75	31
FV31	3" 125# FLG	3" 125# FLG	8.00	9.25	35
FV41	4" 125# FLG	4" 125# FLG	9.50	10.50	53
FV51	5" 125# FLG	5" 125# FLG	10.50	12.75	70

Also available with stainless steel trim.

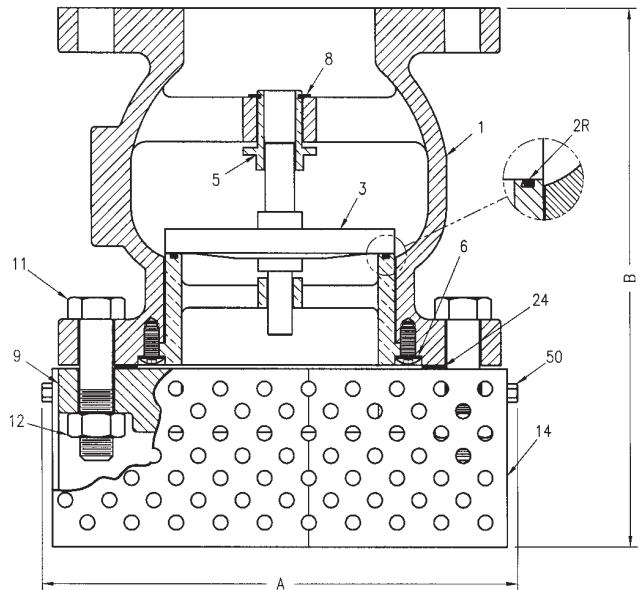

Submittal Sheet for Crispin FV Series



6"-16" Class 125 Foot Valve

Date: October, 2001

Specifications

Foot Valve(s) shall be installed on the pump suction to prevent the pump column from draining upon pump shutdown.

The valve(s) shall be silent operating and normally closed. A center guided disc with a Buna-N seat shall provide a drip tight seal. Minimum flow area perpendicular to the direction of flow thru the valve shall be equal to the pipe area. The inlet shall be fitted with a stainless steel screen with a clear opening adequate to provide 3 to 4 times the area of the pipe.

2 1/2"-16" flanged: The valve(s) materials of construction shall include a cast iron body, bronze disc, bushing and seat ring with a Buna-N seal; and stainless steel inlet screen. The flanged pipe connection shall be AN SI Class 125.

The valve(s) shall be model _____ as manufactured by Crispin-Multiplex Manufacturing Co., Berwick, Pennsylvania.

Option: Internal materials of construction will include stainless steel disc, seat ring, and bushing.

Size Specifications

MODEL	INLET SIZE	OUTLET SIZE	A	B	WGHT.
FV61	6" 125# FLG	6" 125# FLG	11.50	16.00	100
FV81	8" 125# FLG	8" 125# FLG	14.00	20.75	166
FV101	10" 125# FLG	10" 125# FLG	16.50	25.75	276
FV121	12" 125# FLG	12" 125# FLG	19.50	26.75	396
FV141	14" 125# FLG	14" 125# FLG	21.50	29.00	465
FV161	16" 125# FLG	16" 125# FLG	23.50	32.75	605

Also available with stainless steel trim.

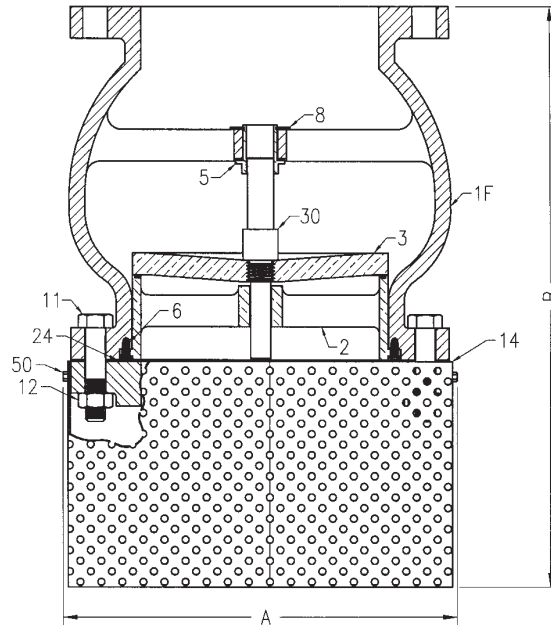

Valve Parts List

ITEM	DESCRIPTION	MATERIAL	ASTM
1	BODY	CAST IRON	A126 CL.B
2	RESILIENT SEAT	BRONZE/BUNA-N RUBBER	B62/D2000
3	DISC	BRONZE	B62
5	BUSHING	BRONZE	B62
6	SCREW	STAINLESS STEEL	A193
8	RETAINING RING	STAINLESS STEEL	A240
9	MOUNTING FLANGE	CAST IRON	A126 CL.B
11	BOLT	ZINC PLATED	A193
12	NUT	ZINC PLATED	A194
14	SCREEN	STAINLESS STEEL	A240
24	GASKET	ARMSTRONG N-8092	N/A
30	SHAFT	BRONZE	B62
50	SCREEN RETAINING SCREW	STAINLESS STEEL	A193

SUBMITTAL SHEET FOR FV SERIES



Submittal Sheet for Crispin FV Series

18"-24" Flanged Foot Valve

Drawing Date: October, 2001

SUBMITTAL SHEET FOR FV SERIES

Valve Parts List

ITEM	DESCRIPTION	MATERIAL	ASTM
1	BODY	CAST IRON	A126 CL.B
2	RESILIENT SEAT	BRONZE/BUNA-N RUBBER	B62/D2000
3	DISC	BRONZE	B62
5	BUSHING	BRONZE	B62
6	SCREW	STAINLESS STEEL	A193
8	RETAINING RING	STAINLESS STEEL	A240
9	MOUNTING FLANGE	CAST IRON	A126 CL.B
11	BOLT	CAD. PLATED STEEL	A193
12	NUT	CAD. PLATED STEEL	A194
14	SCREEN	STAINLESS STEEL	A240
24	GASKET	ARMSTRONG N-8092	N/A
30	SHAFT	BRONZE	B62
30A	SHAFT	BRONZE	B62
31	NUT	STAINLESS STEEL	194
50	SCREEN RETAINING SCREW	STAINLESS STEEL	A193

Specifications

Foot Valve(s) shall be installed on the pump suction to prevent the pump column from draining upon pump shutdown. The valve(s) shall be silent operating and normally closed. A center guided disc with a Buna-N seat shall provide a drip tight seal. Minimum flow area perpendicular to the direction of flow thru the valve shall be equal to the pipe area. The inlet shall be fitted with a stainless steel screen with a clear opening adequate to provide 3 to 4 times the area of the pipe.

18"-24" flanged: The valve(s) materials of construction shall include a cast iron body, bronze disc, bushing and seat ring with a Buna-N seal; and stainless steel inlet screen. The flanged pipe connection shall be AN SI Class 125.

The valve(s) shall be model _____ as manufactured by Crispin-Multiplex Manufacturing Co., Berwick, PA.

Option: Internal materials of construction will include stainless steel disc, seat ring, and bushing.

Size Specifications

MODEL	INLET SIZE	OUTLET SIZE	A	B	WGHT.
FV181	18" 125# FLG	18" 125# FLG	25.00	28.00	725
FV201	20" 125# FLG	20" 125# FLG	31.00	35.00	1059
FV241	24" 125# FLG	24" 125# FLG	37.00	38.28	1600

