



Gas Springs & Hydraulic Dampers



ACE Controls Inc.
World leader in deceleration technology
ISO 9001:2000 Certified

ACE Controls, Inc.
World Headquarters
Farmington, Michigan U.S.A.
800-521-3320

ACE Stossdampfer GMBH
Langenfeld, Germany
0-2173-922610

ACE Controls Japan Ltd.
Chiba Prefecture, Japan
0-436-246711

ACE Controls International
Merseyside, United Kingdom
1-925-227171

Founded over 35 years ago, ACE Controls, Inc. is recognized as the world leader in the design and manufacture of deceleration devices for a wide variety of industries. Facilities are located in the United States, England, Germany and Japan together with extensive distribution throughout the world. ACE is able to provide an excellent and responsive sales and support network.

The ACE Controls product line includes gas springs, hydraulic dampers, industrial shock absorbers, stacker crane shocks as well as crane and heavy industrial shock absorbers, velocity controls, rotary dampers and TUBUS elastomer bumpers.

ACE's innovations include adjustable and self-compensating shock absorbers as well as CAD files and simulation software for shock absorber

applications and product selection. ACE Controls, Inc. is a certified ISO 9001:2000 manufacturer.

The ACE line of gas springs is ideal for counterbalancing loads to provide assistance in both lifting and lowering covers, guards and panels, as well as limiting the rate at which heavy covers, etc. can be moved.

ACE Controls' Applications Department is one of the most advanced in the industry. Engineers are available to assist you by providing full technical support for your gas spring and hydraulic damper application requirements. The ACE Controls Applications Department can be reached at 800-521-3320.

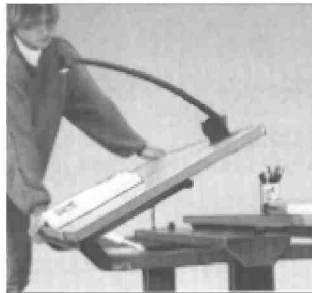

Additional Gas Spring Applications Include:

Computers
 Photocopiers
 Aircraft Overhead Compartments
 Aircraft Galley Equipment
 Truck Engine Covers
 Truck Side Panels
 Electrical Enclosure Cabinets

Boat Engine Hatches
 Bus/Coach Engine Covers
 Bus/Coach Courier Seats
 Fork Lifts
 Conveyor Belt Tensioning
 Roof Ventilation Hatches
 Manhole/Access Covers

Molding Machines
 Executive Desks
 Smoke Vents
 Stair Lifts
 Security Cabinets
 Washing Machine Lids
 Automatic Cash Dispensers

Function

In every action involving a lifting or lowering motion, e.g. when opening a hatch lid, there are masses in movement which must be controlled.

If this is ignored, then the kinetic energy caused by the mass in motion can result in considerable damage. There are several ways that ACE offers to control this motion.

a) Shock absorbers - used when no return assistance is required and no restriction of the velocity is required, control being provided shortly before the mechanical components make contact.

b) Velocity controls - used when no return assistance is required, and control of velocity throughout the motion is required.

c) Rotary dampers - used in light load situations requiring no return assistance and controlled velocity throughout the motion.

d) Gas springs - used when return assistance or load support (counterbalance) is required throughout the motion.

The gas springs can be provided in a wide range of body sizes, stroke lengths and the force provided can be specified to suit the specific application. The extension and compression velocities can also be customized on request.

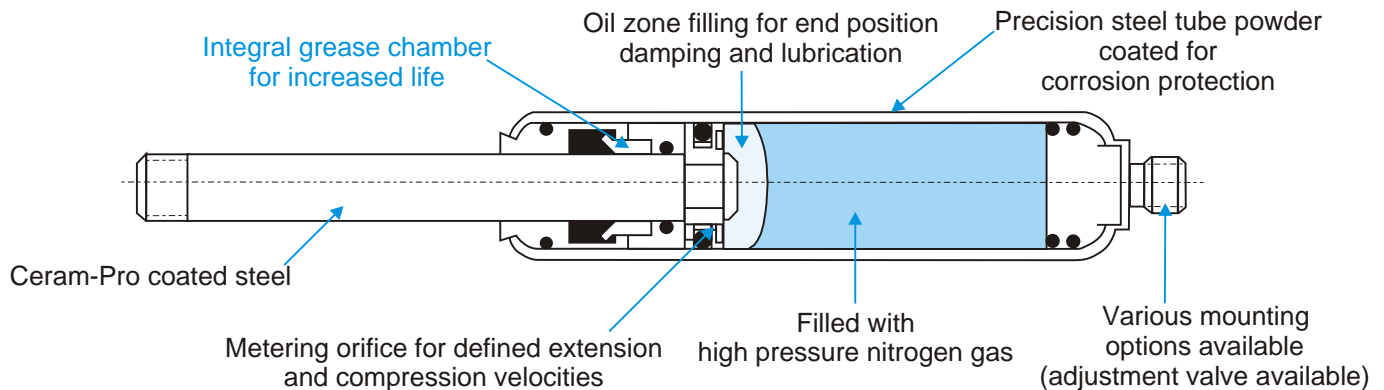

Construction and Operation

ACE gas springs are maintenance free self-contained systems which are filled with high pressure nitrogen gas to a defined pressure. They also contain a small quantity of oil to provide end position damping.

During operation, the nitrogen gas flows through the metering orifice and allows the load to be lowered in a controlled manner. The force of the gas spring works against the weight and prevents it from accelerating and damaging mechanical components on closure.

Upon reversal the nitrogen flows back through the piston orifice and the gas spring force assists the action, reducing the effort required to reset the mechanism.

The opening and closing speeds can be varied by altering the size of the metering orifice to order.

For cushioning on the extension stroke, mount with the rod down. For cushioning on the compression stroke, mount with the rod up.

An integral grease chamber behind the rod seals ensures lasting lubrication which can increase the life of ACE gas springs by at least 100% more than other products on the market.

The Ceram-Pro coated steel piston rod and powder coated precision steel body ensure excellent corrosion protection and provide a long maintenance free working life.

The wide variety of available mounting accessories provide mounting versatility and options.

Use the following application parameters to calculate a suitable ACE gas spring:

1. Weight of the lid or flap **lbs (kg)**
2. Position of the center of gravity **in (mm)**
3. Sketch of the application layout

Symbols used:

- | | | |
|----------------|-----------------------------------|-----------------|
| W | Force due to weight of the lid | lbs (kg) |
| R _w | Radius of center of gravity | in (mm) |
| L _G | Number of gas springs in parallel | in (mm) |
| s | Center of gravity | - |
| D | Pivot point | - |

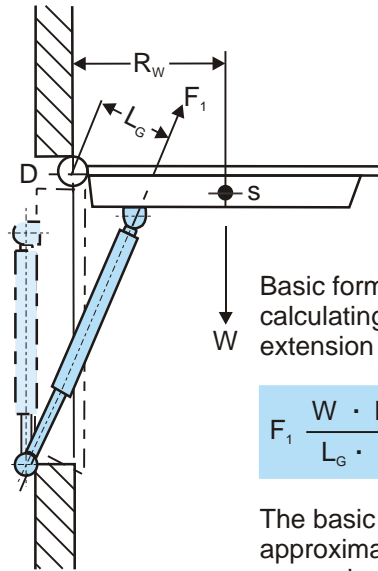

Example

$$\begin{aligned}
 W &= 90 \text{ lbs (41 kg)} \\
 R_w &= 30 \text{ in (762 mm)} \\
 L_G &= 6 \text{ in (152.4 mm)} \\
 n &= 2 \\
 F_1 &= \frac{90 \cdot 30}{6 \cdot 2} \\
 F_1 &= 225 \text{ lbs (1000 N)}
 \end{aligned}$$

Basic formula for calculating required extension force:

$$F_1 = \frac{W \cdot R_w}{L_G \cdot n} \text{ lbs (N)}$$

Chosen force:
 $F_1 = 225 \text{ lbs (1000 N)}$
 Chosen gas spring:
 GS-22-200-AA-1000

The basic formula given enables an approximate calculation of the required gas spring force for one mounting position geometry.

In order to save time we recommend that the calculation and selection of the most suitable gas spring be completed by ACE.

With our sophisticated selection software we can quickly determine the resultant opening or closing forces throughout the complete movement and recommend the optimum mounting points, gas spring model and nominal force.

Please fax us the completed Application Data form on page 10.

ACE gas springs are self contained, maintenance free devices and are supplied ready for installation. The following points should be noted to ensure the longest possible working life:

Gas spring force F_1 : Gas springs are filled with nitrogen at very high pressures and under no circumstances should they be opened or subjected to excessive tensile loads.

External force F_H : for example manual (hand) force to close the flap.

Weight force W : due to mass acting at center of gravity.

Gas spring orientation as desired:
 With piston rod downwards => damping effective at end of extension stroke.
 With piston rod upwards => damping effective at end of compression stroke.

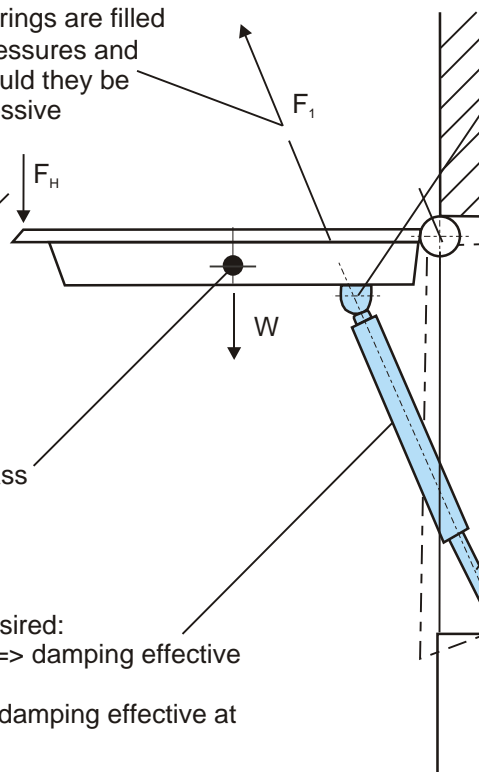

Choose a standard available gas spring from the ACE range featured in this catalog before determining the mounting position coordinates, or preferably allow ACE to do the calculations and provide a printout suggesting the most suitable model and mounting positions.

Where possible arrange the mounting positions so that the effective torque provided by the gas spring positively holds the flap in its closed position.

Protect the piston rod from impact damage, scratches, dirt or paint contamination. The gas spring barrel must not be deformed or damaged.

The gas spring must not be exposed to bending forces or side loads. If using eyelet fittings support the eye on both sides and allow some float. We recommend using ball joints on most applications as these help to eliminate any misalignment.

Gas Spring Force - Stroke Characteristics

Gas Spring - Push Type

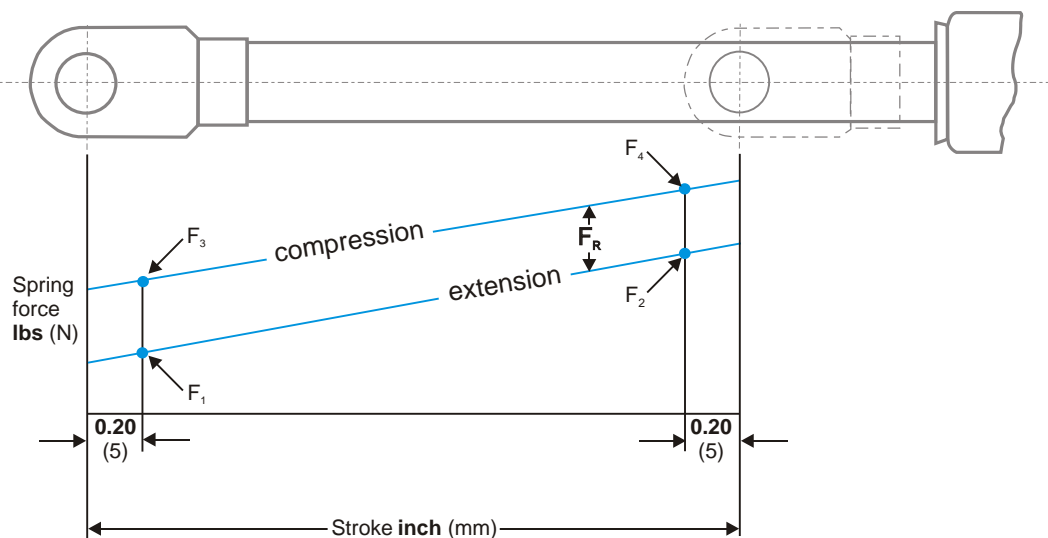

Type	Progression* approximate %	Friction F_R approximate lbs (N)
GS-15	27	4 (20)
GS-19	33	7 (30)
GS-22	38	7 (30)
GS-28	52	9 (40)

F_1 = Nominal Force at 68° F (20° C) (this figure is normally used when specifying gas springs)

F_1 to F_2 = Force on extension stroke

F_3 to F_4 = Force on compression stroke

*The progression (slope of the force line in the characteristic diagram above) is due to the reduction of the internal gas volume as the piston rod moves from its initial position to its fully stroked position. The approximate progression values given above for standard springs can be altered upon request.

Effect of temperature: The nominal F_1 force figure is given at 68° F (20° C).

An increase in temperature of 18° F or 10° C will result in approximately a 3.4% increase in the force.

General extension force tolerance is (+40N/-20N).

Note: Initial breakaway force may be higher if units are stored for a long period without use.

Additional Gas Spring Available Options

1. Lockable gas springs: GBF-28/GBS-28
2. Gas springs (push type): GS-40
3. Gas springs (pull type): GZ-28, GZ-40

Note: GS and GZ gas springs are available as fixed force options. See page 10 for additional information.

Extension force range **2 to 90 lbs** (10 to 400 N)

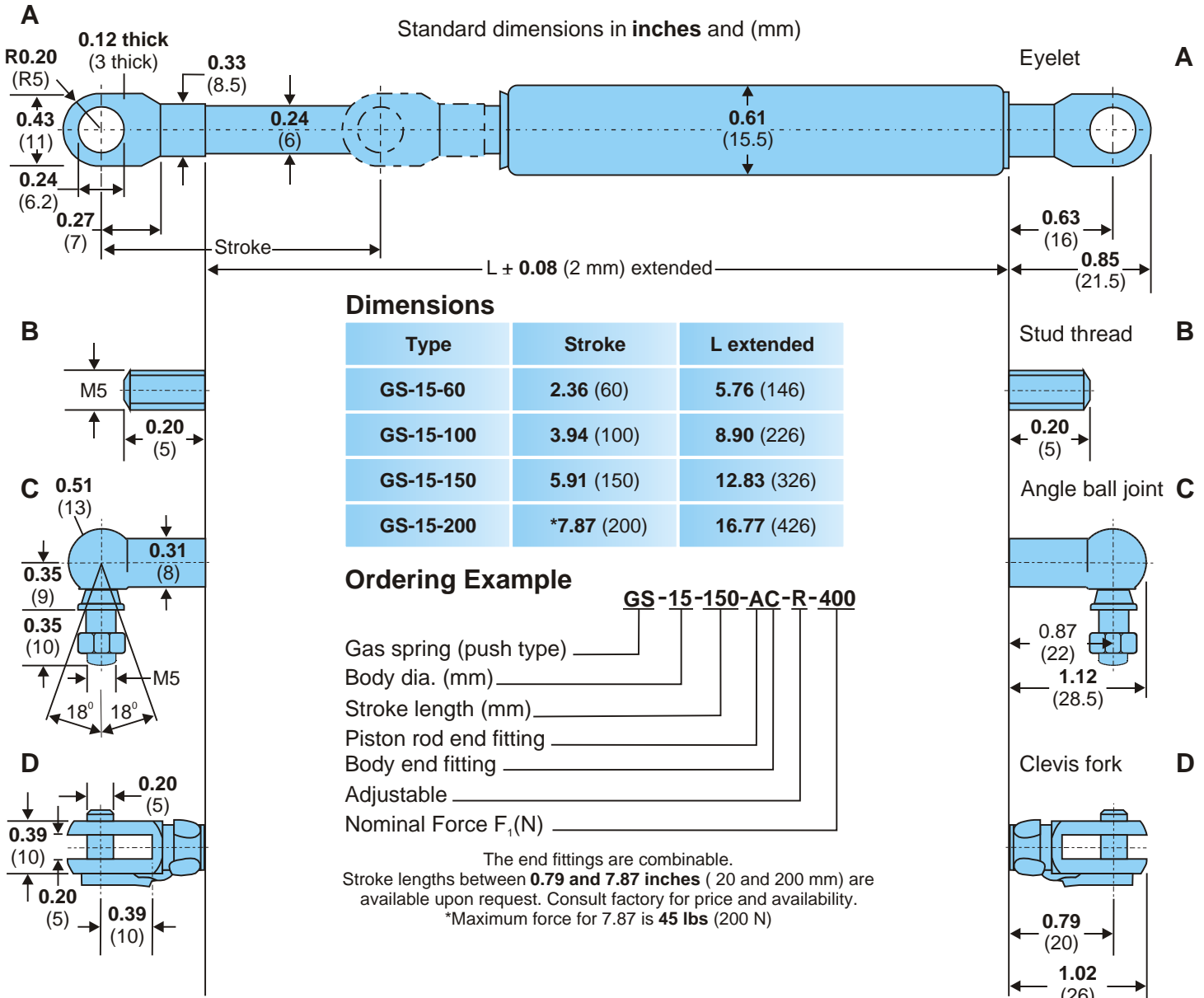

Technical Data

ACE Gas springs are self contained and maintenance free.

Mounting position: Can be mounted in any position, but we recommend mounting with piston rod downwards so that damping is effective at end of extension stroke.

End position damping length: approximately 0.39 (10 mm)

Force progression: approximately 27%

Temperature range: -22 to +176° F (-30 to +80° C)

Fluid: nitrogen gas and oil (for end position damping)

Force range: 2 to 90 lbs (10 to 400 N)

Material: Ceram-Pro coated steel piston rod for corrosion protection, body: powder coated steel

End fittings: zinc plated steel or aluminum

Options: without damping, extended length damping, special force curves, special lengths, alternative end fittings, M5 adjusting knob

Mounting Brackets (zinc plated steel)

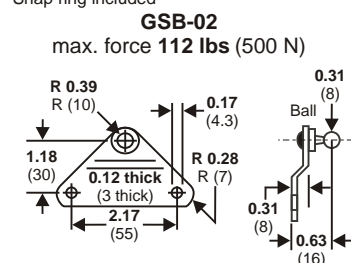
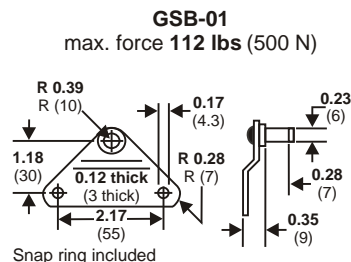

Note: Remember rising force curve on compression.

Extension force range **11 to 157 lbs** (50 to 700 N)

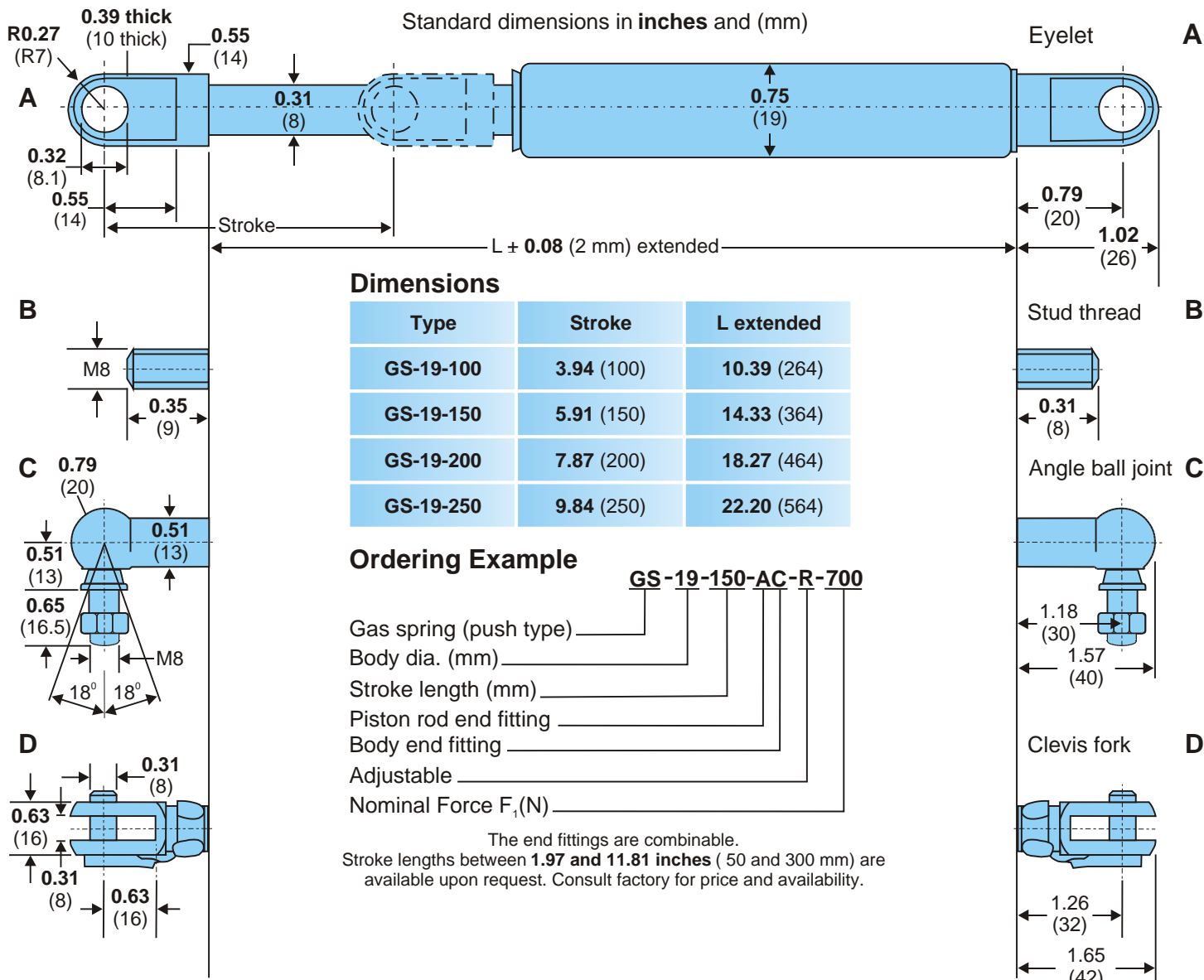

Dimensions

Type	Stroke	L extended
GS-19-100	3.94 (100)	10.39 (264)
GS-19-150	5.91 (150)	14.33 (364)
GS-19-200	7.87 (200)	18.27 (464)
GS-19-250	9.84 (250)	22.20 (564)

Ordering Example

GS-19-150-AC-R-700

- Gas spring (push type) _____
- Body dia. (mm) _____
- Stroke length (mm) _____
- Piston rod end fitting _____
- Body end fitting _____
- Adjustable _____
- Nominal Force F_1 (N) _____

The end fittings are combinable.
Stroke lengths between **1.97 and 11.81 inches** (50 and 300 mm) are available upon request. Consult factory for price and availability.

Technical Data

ACE Gas springs are self-contained and maintenance free.

Mounting position: Can be mounted in any position, but we recommend mounting with piston rod downwards so that damping is effective at end of extension stroke.

End position damping length: approximately 0.39 (10 mm)

Force progression: approximately 33%

Temperature range: -22 to +176° F (-30 to +80° C) with special seals up to + 392° F (+200° C)

Fluid: nitrogen gas and oil (for end position damping)

Force range: 11 to 157 lbs (50 to 700 N)

Material: Ceram-Pro coated steel piston rod for corrosion protection, body: powder coated steel

End fittings: zinc plated steel or aluminum

Options: without damping, extended length damping, special force curves, special lengths, alternative end fittings, M8 adjusting knob

Mounting Brackets (zinc plated steel)

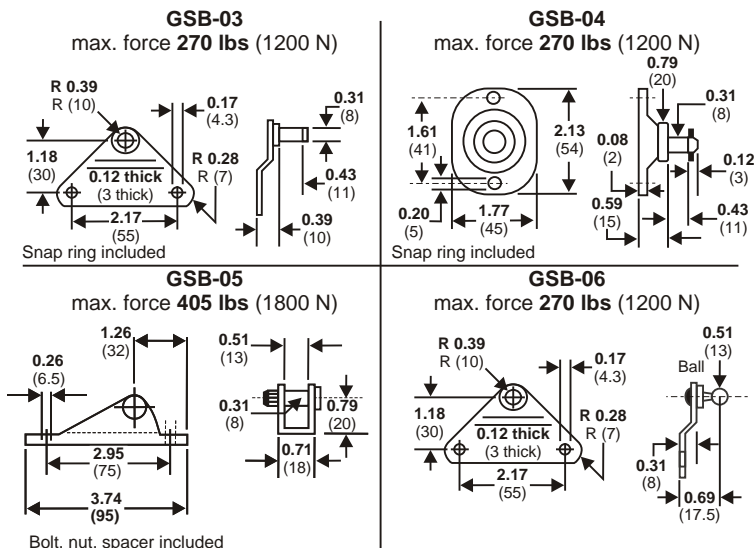

Note: Remember rising force curve on compression.

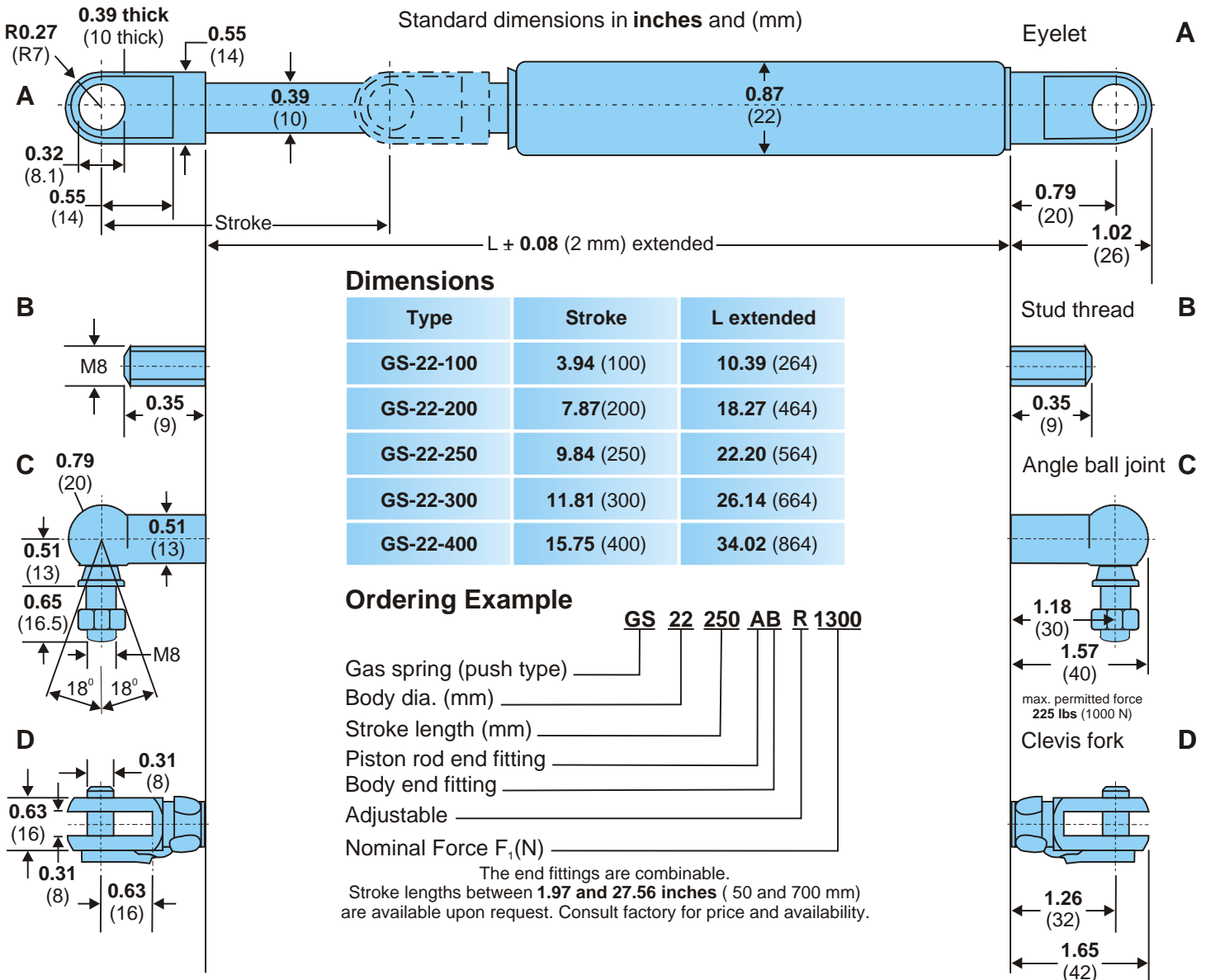

Technical Data

ACE Gas springs are self-contained and maintenance free.

Mounting position: Can be mounted in any position, but we recommend mounting with piston rod downwards so that damping is effective at end of extension stroke.

End position damping length: approximately 0.39 (10 mm)

Force progression: approximately 38%

Temperature range: -22 to +176° F (-30 to +80° C) with special seals up to +392° F (+200° C)

Fluid: nitrogen gas and oil (for end position damping)

Force range: 18 to 292 lbs (80 to 1300 N)

Material: Ceram-Pro coated steel piston rod for corrosion protection, body: powder coated steel

End fittings: zinc plated steel or aluminum

Options: without damping, extended length damping, special force curves, special lengths, alternative end fittings, M8 adjusting knob

Mounting Brackets (zinc plated steel)

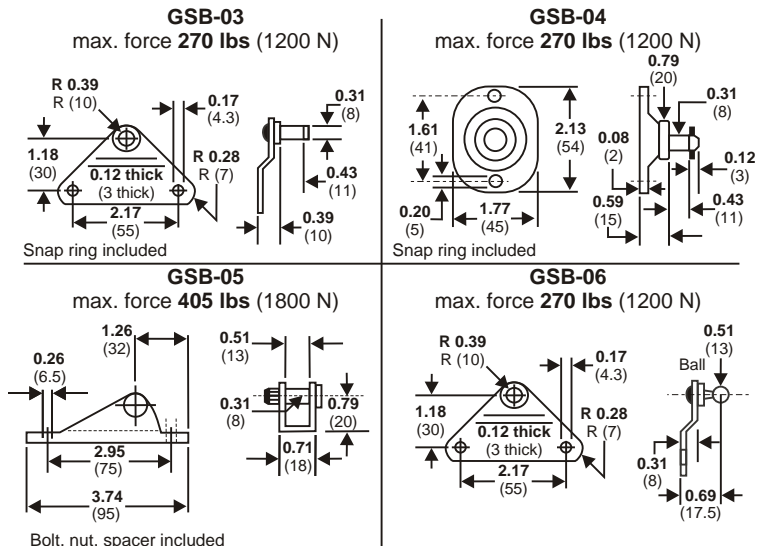

Note: Remember rising force curve on compression.

Extension force range **22 to 562 lbs** (100 to 2,500 N)

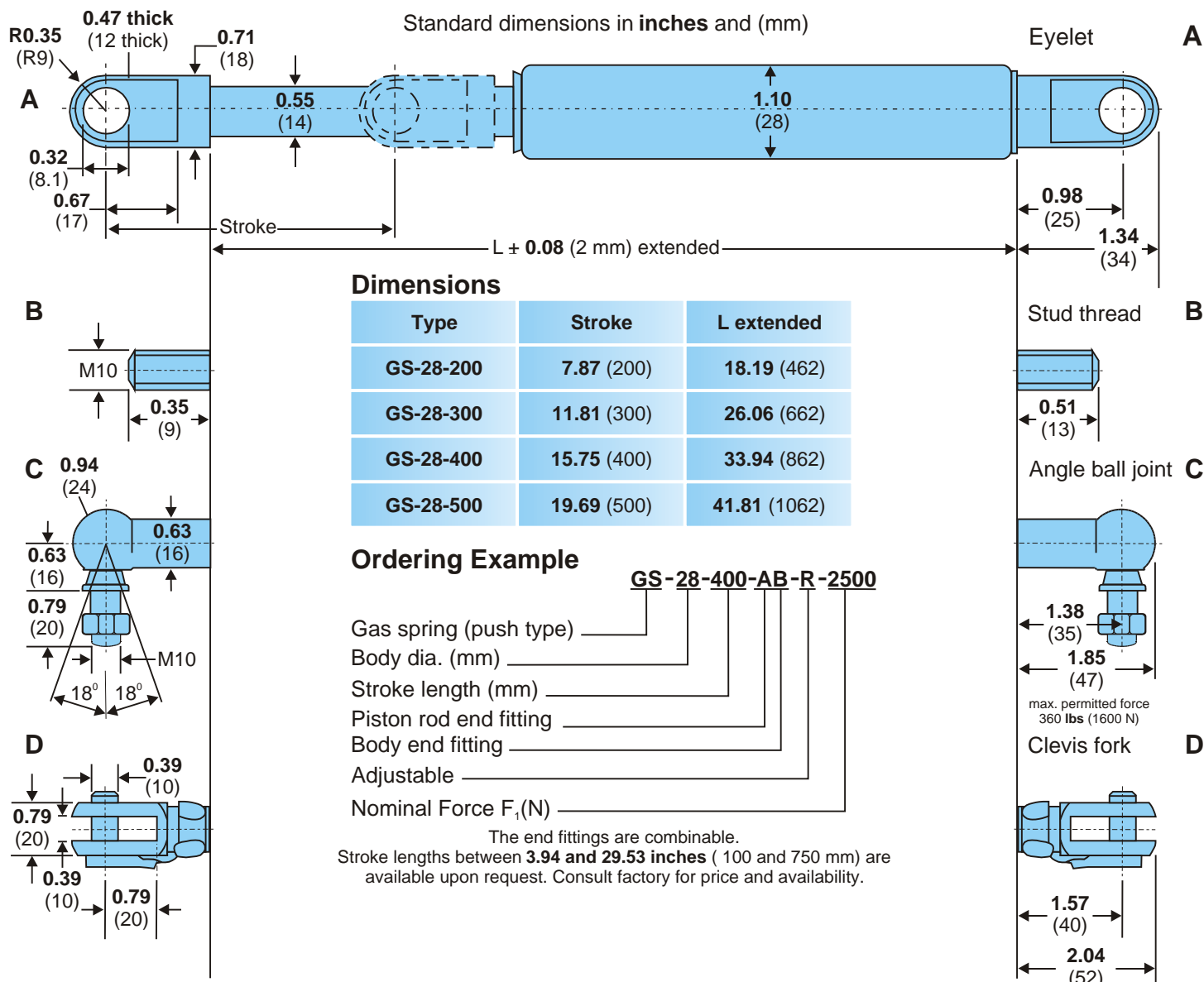

Technical Data

ACE Gas springs are self-contained and maintenance free.

Mounting position: Can be mounted in any position, but we recommend mounting with piston rod downwards so that damping is effective at end of extension stroke.

End position damping length: approximately 0.39 (10 mm)

Force progression: approximately 52%

Temperature range: -22 to +176° F (-30 to +80° C) with special seals up to +392° F (+200° C)

Fluid: nitrogen gas and oil (for end position damping)

Force range: 22 to 562 lbs (100 to 2500 N)

Material: Ceram-Pro coated steel piston rod for corrosion protection, body: powder coated steel

End fittings: zinc plated steel or aluminum

Options: without damping, extended length damping, special force curves, special lengths, alternative end fittings, M10 adjusting knob

Mounting Brackets (zinc plated steel)

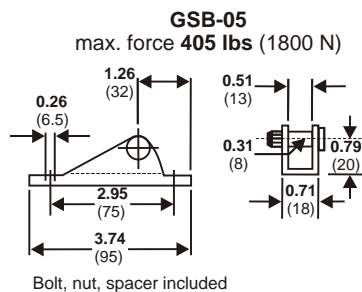

Note: Remember rising force curve on compression.

Requirement per year _____

Name _____
 Company _____
 Address _____
 Telephone _____
 Fax _____
 E-mail _____
 Comments _____

Gas Spring Type



Input Data

Radius of center of gravity	R_w	_____	in (mm)
Moving weight	w	_____	lbs (kg)
Radius of hand force	R_H	_____	in (mm)
Desired max. handforce	F_H	_____	lbs (N)
No of gas springs in parallel	n	_____	pcs
Starting angle (0 to 360°)		_____	°
Opening angle (-360 to +360°)	a	_____	°

Gas Spring fixing points (complete if desired)

Fixed point	(x-coord.) x_1	_____	in (mm)
Fixed point	(y-coord.) y_1	_____	in (mm)
Moving point	(x-coord.) x_2	_____	in (mm)
Moving point	(y-coord.) y_2	_____	in (mm)

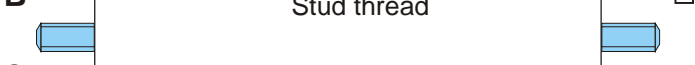
Desired Mounting Fittings

- | | | | |
|----------------------------|---|------------------|----------------------------|
| <input type="checkbox"/> A |  | Eyelet | <input type="checkbox"/> A |
| <input type="checkbox"/> B |  | Stud thread | <input type="checkbox"/> B |
| <input type="checkbox"/> C |  | Angle ball joint | <input type="checkbox"/> C |
| <input type="checkbox"/> D |  | Clevis fork | <input type="checkbox"/> D |

Please fax to:
ACE Controls, Inc.
248-476-2470

ACE Controls is dedicated to continuous improvement. We therefore reserve the right to change models, dimensions or specifications without notice or obligation.

© ACE Controls, Inc. 2003. No portion of this catalog, except where specified, may be reproduced without ACE Controls' written permission.

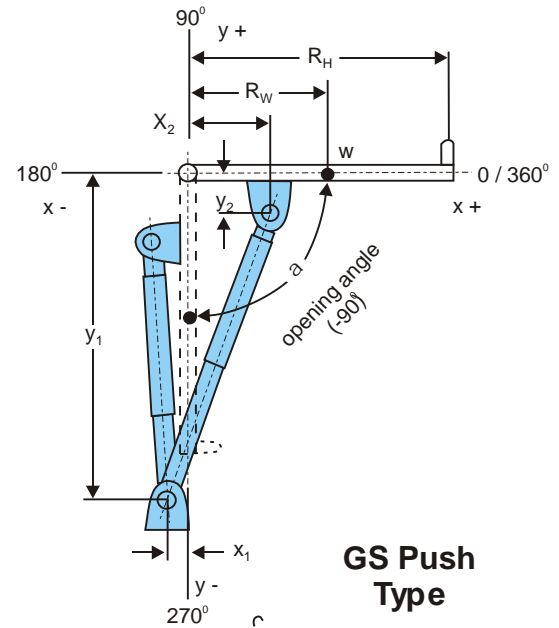

GS Push Type

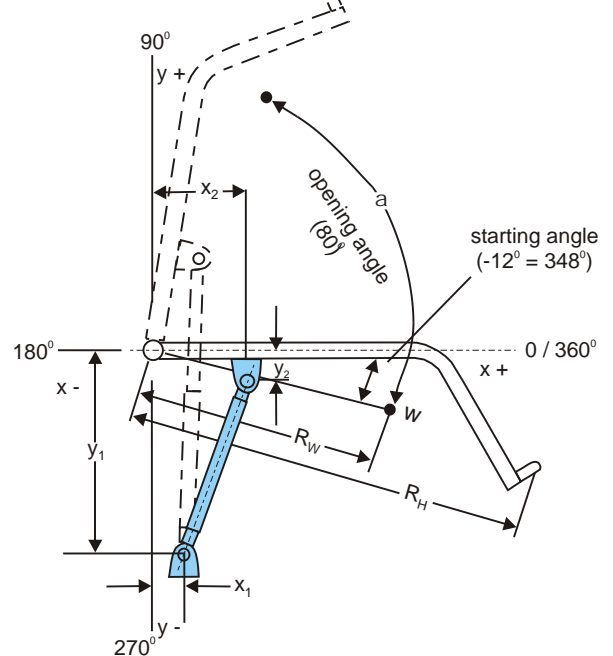

Lockable GBF/GBS Type

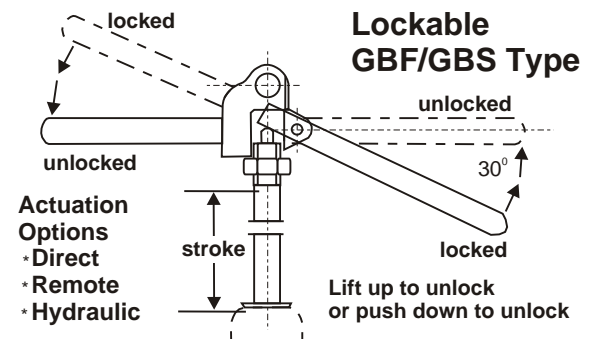

GS, GZ types are available in 19 - 28 mm diameters with optional lengths. GBF and GBS types are available in 22 mm, 28 mm and 40 mm diameters with optional lengths. For range of types not shown in this catalog consult your local distributor or ACE Controls directly.
NOTE: GZ units are pull type and are a special order.

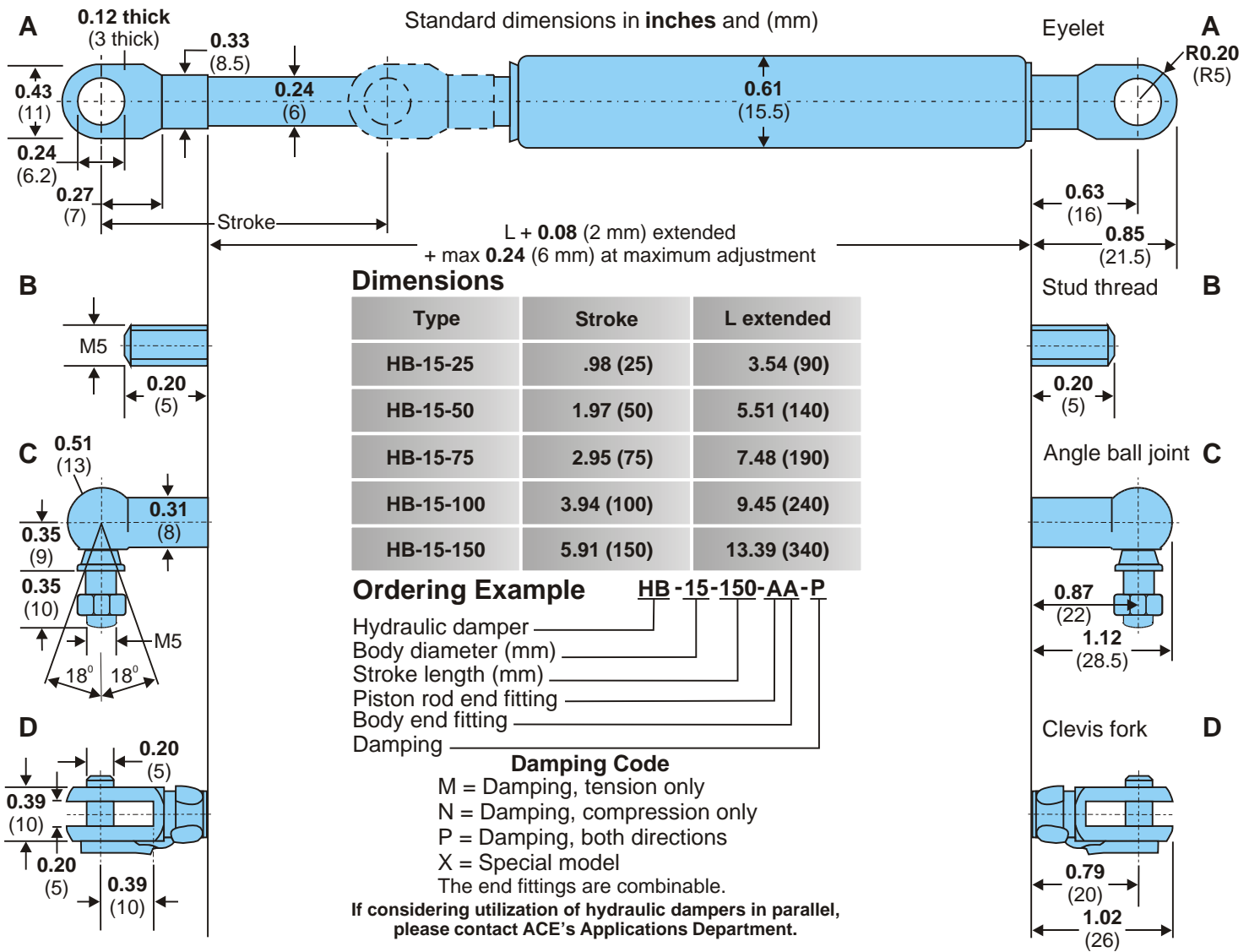

Technical Data

ACE hydraulic dampers are self-contained and maintenance free.

Mounting position: can be mounted in any position

Adjustment: pull the piston rod out to its fully extended position. While pulling on the rod, turn it clockwise or counter-clockwise until the desired damping is achieved. The adjustment is multi-turn and correct damping may require several trial and error adjustments.

Attention: dampers have free travel accounting for approximately 20% of stroke

Mechanical stop: required 1 to 1.5 mm before end of stroke

Temperature range: -22° to +176° F (-30° to +80° C), with special seals up to 248° F (120° C)

Fluid: hydraulic oil

Minimum force: 4 lbs (20 N)
Maximum force: 180 lbs (800 N)

Material: Ceram-Pro coated steel piston rod for corrosion protection, body: powder coated steel

End fittings: zinc plated steel or aluminum

Options: units with other damping characteristics, other stroke lengths, special seal materials, alternative end fittings and protective rod sleeves

Mounting Brackets (zinc plated steel)

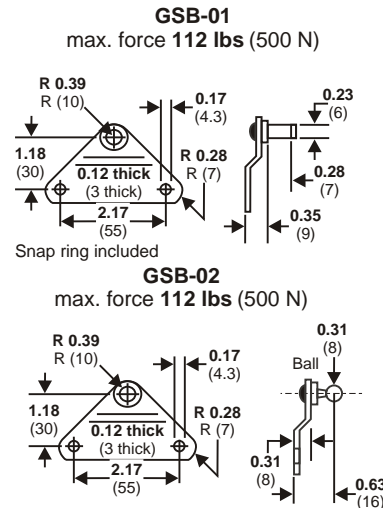

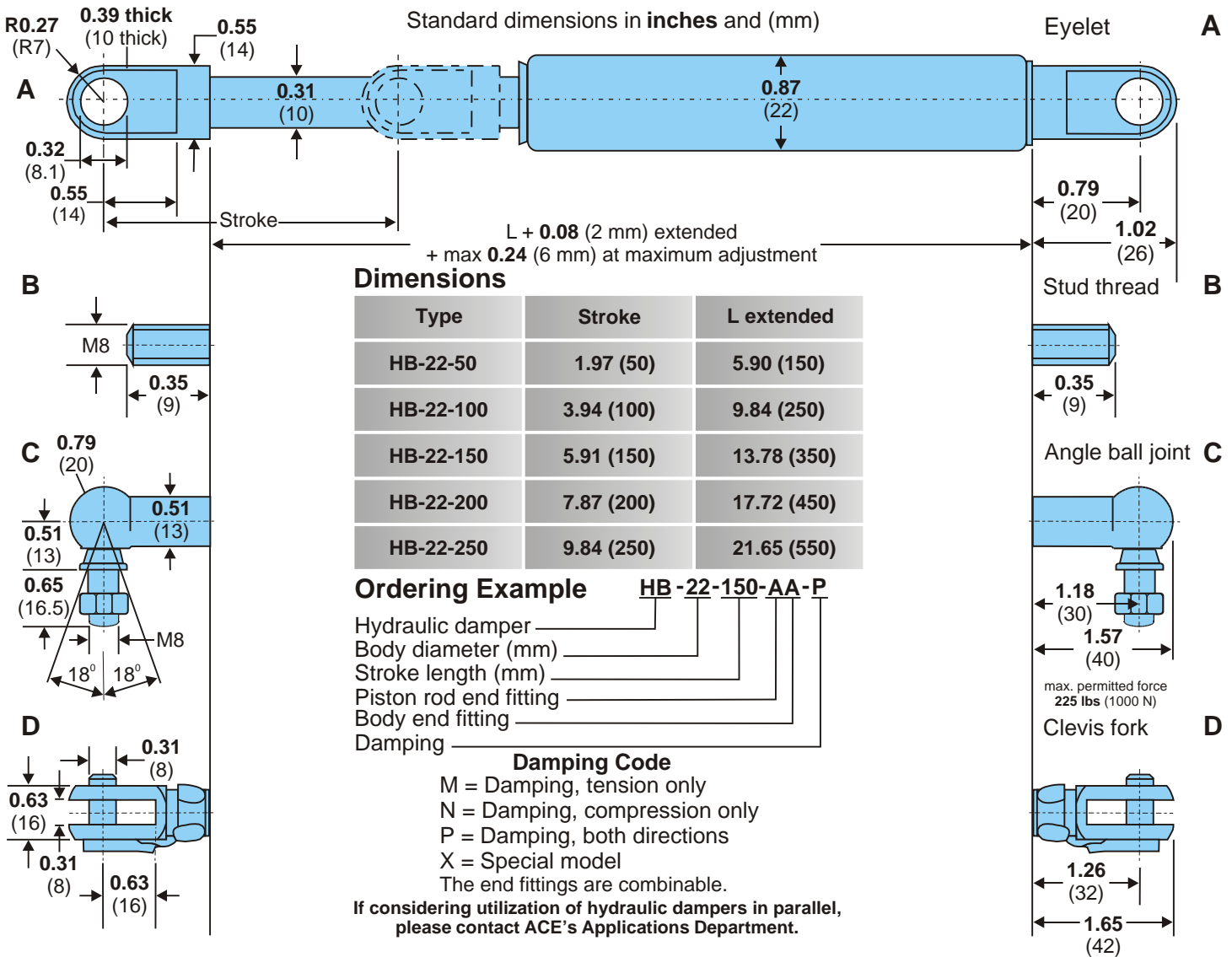

Technical Data

ACE hydraulic dampers are self-contained and maintenance free.

Mounting position: can be mounted in any position

Adjustment: pull the piston rod out to its fully extended position. While pulling on the rod, turn it clockwise or counter-clockwise until the desired damping is achieved. The adjustment is multi-turn and correct damping may require several trial and error adjustments.

Attention: dampers have free travel accounting for approximately 20% of stroke

Mechanical stop: required 1 to 1.5 mm before end of stroke

Temperature range: -22° to +176° F (-30° to +80° C), with special seals up to 248° F (120° C)

Fluid: hydraulic oil

Minimum force: 7 lbs (30 N)
Maximum force: 405 lbs (1,800 N)

Material: Ceram-Pro coated steel piston rod for corrosion protection, body: powder coated steel

End fittings: zinc plated steel aluminum

Options: units with other damping characteristics, other stroke lengths, special seal materials, alternative end fittings and protective rod sleeves

Mounting Brackets (zinc plated steel)

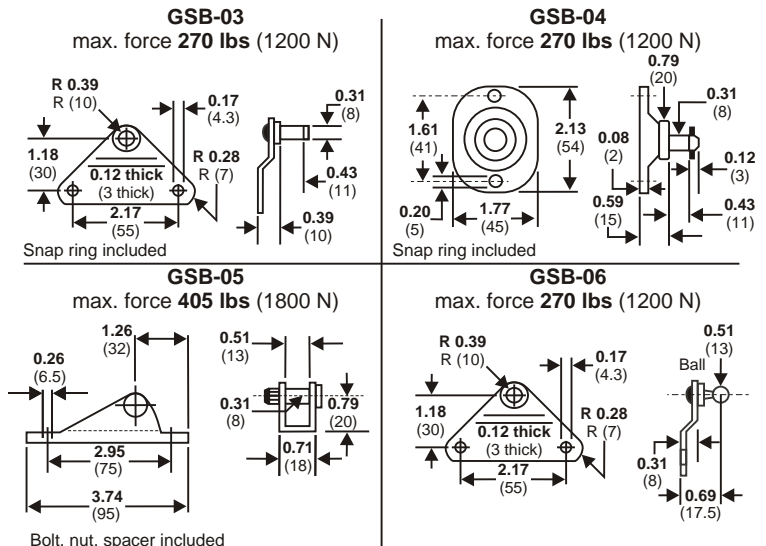

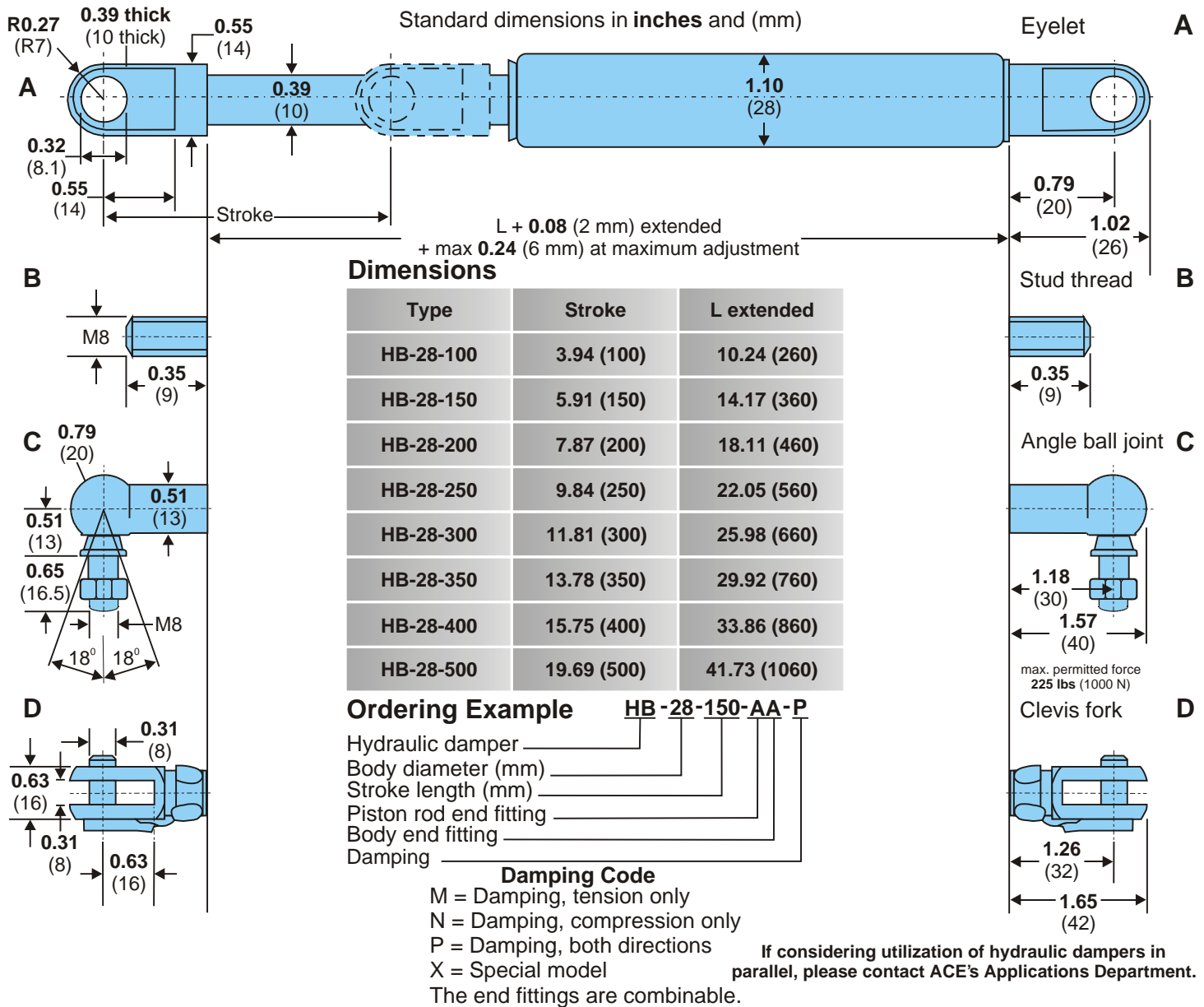

Technical Data

ACE hydraulic dampers are self-contained and maintenance free.

Mounting position: can be mounted in any position

Adjustment: pull the piston rod out to its fully extended position. While pulling on the rod, turn it clockwise or counter-clockwise until the desired damping is achieved. The adjustment is multi-turn and correct damping may require several trial and error adjustments.

Attention: dampers have free travel accounting for approximately 20% of stroke

Mechanical stop: required 1 to 1.5 mm before end of stroke

Temperature range: -22° to +176° F (-30° to +80° C), with special seals up to 248° F (120° C)

Fluid: hydraulic oil

Minimum force: 7 lbs (30 N)
Maximum force: 674 lbs (3,000 N)

Material: Ceram-Pro coated steel piston rod for corrosion protection, body: powder coated steel

End fittings: zinc plated steel or aluminum

Options: units with other damping characteristics, other stroke lengths, special seal materials, alternative end fittings and protective rod sleeves

Mounting Brackets (zinc plated steel)

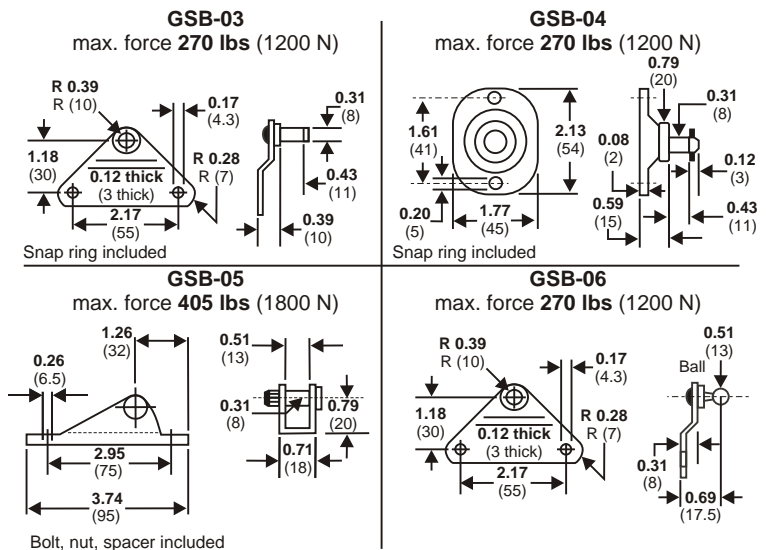

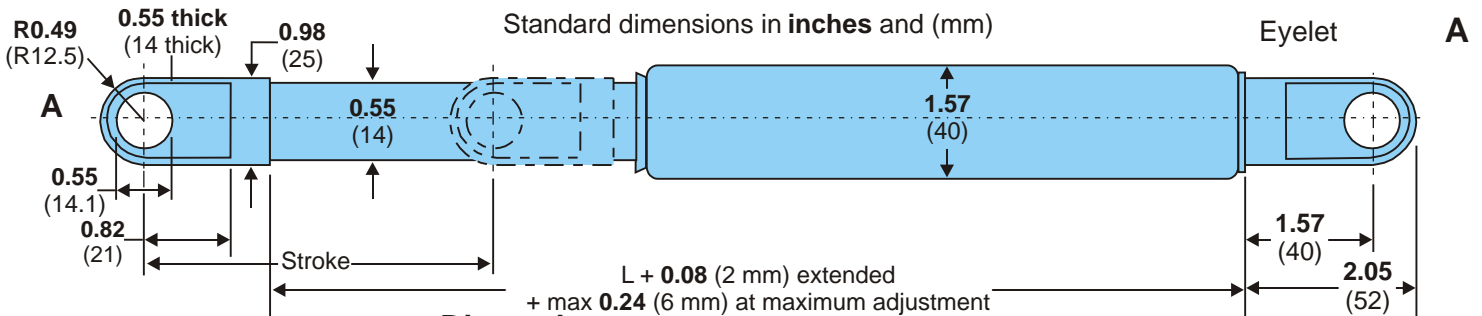

Dimensions

Type	Stroke	L extended
HB-40-100	3.94 (100)	10.83 (275)
HB-40-150	5.91 (150)	14.76 (375)
HB-40-200	7.87 (200)	18.70 (475)
HB-40-300	11.81 (300)	26.57 (675)
HB-40-400	15.75 (400)	34.45 (875)
HB-40-500	19.69 (500)	42.32 (1075)
HB-40-600	23.62 (600)	50.20 (1275)
HB-40-700	27.56 (700)	58.07 (1475)
HB-40-800	31.50 (800)	65.94 (1675)

Ordering Example

HB - 40 - 300 - AA - P
 Hydraulic damper _____
 Body diameter (mm) _____
 Stroke length (mm) _____
 Piston rod end fitting _____
 Body end fitting _____
 Damping _____

Damping Code

- M = Damping, tension only
 - N = Damping, compression only
 - P = Damping, both directions
 - X = Special model
- If considering utilization of hydraulic dampers in parallel, please contact ACE's Applications Department.
 The end fittings are combinable.

Technical Data

ACE hydraulic dampers are self-contained and maintenance free.

Mounting position: can be mounted in any position

Adjustment: pull the piston rod out to its fully extended position. While pulling on the rod, turn it clockwise or counter-clockwise until the desired damping is achieved. The adjustment is multi-turn and correct damping may require several trial and error adjustments.

Attention: dampers have free travel accounting for approximately 20% of stroke

Mechanical stop: required 1 to 1.5 mm before end of stroke

Temperature range: -22° to +176° F (-30° to +80° C), with special seals up to 248° F (120° C)

Fluid: hydraulic oil

Minimum force: 7 lbs (30 N)
Maximum force: 2,248 lbs (10,000 N)

Material: Ceram-Pro coated steel piston rod for corrosion protection, body: powder coated steel

End fittings: zinc plated steel or aluminum

Options: units with other damping characteristics, other stroke lengths, special seal materials, alternative end fittings and protective rod sleeves

Mounting Bracket (zinc plated steel)

ME14

max. force **2,248 lbs (10,000 N)**

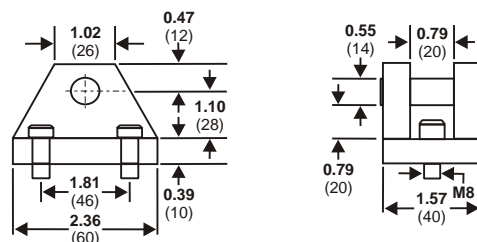

ACE Hydraulic Dampers

ACE Controls hydraulic dampers are the economical choice for solving your automation damping problems. These maintenance free controls are ideal for drilling and tapping equipment, pick and place automation, swinging loads, tooling fixtures, lids, slides and more.

ACE hydraulic dampers are versatile and feature single or double-acting designs. Adjustment is easily achieved by pulling and turning the rod until the desired damping speed is attained.

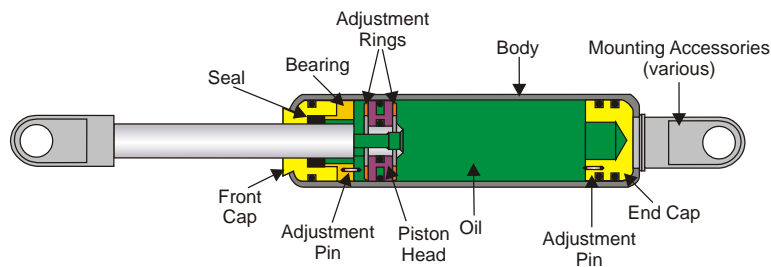

ACE Stocking Distributor Locations - USA, Canada and Latin America

United States

Location	City	Distributor	Telephone
Alabama	Birmingham	Fluid Power Systems, Inc.	205-798-9440
Arizona	Phoenix	Hei-Tek Automation	602-269-7931
	Tempe	Barkley Playman Co.	800-525-8592
Arkansas	Fort Smith	Franklin Electrofluid Co.	800-264-7406
	Little Rock	Franklin Electrofluid Co.	800-272-5665
California	Costa Mesa	Clayton Controls Co.	714-556-9446
	Santa Clara	Nor-Cal Controls, Inc.	408-727-5756
Colorado	Denver	Advanced Air Products Co.	303-778-0800
Connecticut	Bloomfield	Pearse Pearson Co., Inc.	860-242-7777
Florida	Tampa	Gulf Controls Corporation	800-282-9125
Georgia	Alpharetta	Power Systems, Inc.	770-475-1680
	Stone Mountain	TSI Solutions	770-879-3500
Hawaii	Honolulu	Hawaiian Fluid Power	808-833-4516
Illinois	Elk Grove Village	Fluid Power Engineering Co.	847-364-7455
	St. Louis, MO	Air Specialists	314-298-7400
Indiana	Evansville	Neff Engineering Co., Inc.	812-476-7500
	Fort Wayne	Neff Engineering Co., Inc.	219-489-6007
	Indianapolis	Neff Engineering Co., Inc.	317-841-9244
	South Bend	Neff Engineering Co., Inc.	219-272-8282
Kansas	Kansas City	Powerflow Systems, Inc.	913-342-7024
	Overland Park	Fluid Systems & Comp., Inc.	800-747-2552
Kentucky	Elizabethtown	Air Hydro Power, Inc.	270-763-0259
	Glaskow	Air Hydro Power, Inc.	270-651-1353
	Henderson	Air Hydro Power, Inc.	270-827-8008
	Lexington	Air Hydro Power, Inc.	859-255-6155
	Louisville	Air Hydro Power, Inc.	502-451-1000
Louisiana	Shreveport	The Weston Co., Inc.	318-227-1871
	New Orleans	The Weston Co., Inc.	504-486-6653
Michigan	Detroit	ACE Controls, Inc.	800-521-3320
	Flint	Neff Engrg/Kober Sales	810-232-9350
	Grand Rapids	Neff Engineering Co., Inc.	616-554-1974
	Grandville	Michigan Fluid Power, Inc.	616-538-5700
Minnesota	Eden Prairie	Braas Company	612-937-8902
Mississippi	Jackson	AHC Fluid Power	601-969-7022
Missouri	St Louis	Air Specialists	314-298-7400
Nebraska	Omaha	Powerflow Systems, Inc.	402-331-3104
New Jersey	Maplewood	Airoyal Company	973-761-4150
New York	Buffalo	Callahan Motion Control	716-741-8321
	Rochester	Vickers-Warnick	585-426-2510
	Hauppauge, LI	Airoyal Company	631-434-1892
North Carolina	Concord	C.F.T.	704-784-8101
Ohio	Cleveland	ACE Controls, Inc.	800-521-3320
	Dayton	Voelker Controls Co.	937-433-8128
	Toledo	ACE Controls, Inc.	800-521-3320
Oklahoma	Oklahoma City	Shepherd Controls	800-533-1866
	Tulsa	Southwestern Controls	918-663-6777
Pennsylvania	Exton	Dev-Air Corporation	610-524-9927
	Mainland	Air-Oil Systems	800-333-5520
	Pittsburgh	Pennsylvania Controls, Inc.	800-247-9425
	York	RG Group/Dev-Air	717-849-0307
Tennessee	Memphis	Action Fluid Power, Inc.	901-794-0857
	Nashville	Meredith Air Controls, Inc.	615-256-1888
Texas	Auston	Shepherd Controls & Assoc.	800-533-1866
	Dallas	Shepherd Controls & Assoc.	800-533-1866
	Dallas	Southwestern Controls	800-444-9367
	(East Texas)	Shepherd Controls & Assoc.	800-533-1866
	Houston	Shepherd Controls & Assoc.	800-533-1866
	Houston	Southwestern Controls	713-777-2626
	San Antonio	Southwestern Controls	800-444-9369
Utah	Salt Lake City	Advanced Air Products	801-466-1111

United States

Location	City	Distributor	Telephone
Virginia	Fredericksburg	Advanced Pneumatics	540-898-4511
Washington	Seattle	Warden Fluid Dynamics	206-633-0382
	Spokane	Warden Fluid Dynamics	800-234-8265
	Vancouver	Warden Fluid Dynamics	360-696-4946
Wisconsin	Appleton	Neff Engr. of Wisconsin	920-738-5900
	Mequon	Neff Engr. of Wisconsin	262-834-6300

If you are located in one of the following states, please refer to the column on the right for the nearest state with an ACE Controls stocking distributor, and select from the list above and to the left.

State

Alaska
Delaware
Idaho
Iowa
Maine
Maryland
Massachusetts
Montana
Nevada
New Hampshire
New Mexico
North Dakota
Rhode Island
Oregon
South Carolina
South Dakota
Vermont
Washington D.C.
West Virginia
Wyoming

ACE Stocking Distributor State

Washington
Pennsylvania
Washington
Illinois, Kansas, Minnesota
Connecticut
Pennsylvania & Virginia
Connecticut
Washington
California
Connecticut
Arizona, Colorado
Minnesota
Connecticut
Washington
North Carolina
Minnesota
Connecticut
Pennsylvania
Pennsylvania & Virginia
Colorado

Canada

Alberta	Edmonton	Peerless Engrg. Sales Ltd.	780-439-3322
British Columbia	Burnaby	Peerless Engrg. Sales Ltd.	604-659-4100
	Prince George	Peerless Engrg. Sales Ltd.	250-563-2130
New Brunswick	St. John	Cowper	506-634-7763
Nova Scotia	Dartmouth	Cowper	902-468-8036
Ontario	Kingston	Cowper	613-547-9991
	Waterloo	Vickers-Warnick	519-884-8946
	London	Cowper	519-681-0430
	Markham	Cowper	905-294-0204
	Mississauga	Cowper	905-607-2508
	Stoney Creek	Vickers-Warnick	905-662-7737
	Mississauga	Vickers-Warnick	905-564-0188
	Lachine	Cowper	514-637-6746

Latin America

Mexico	Mexico City	Atlas Industrial Supply, Inc.	52-55-5148-8104
	Mexico City	Kopar	52-55-5207-8688
	Monterrey	Atlas Industrial Supply, Inc.	52-11-8342-5260
	Monterrey	Kopar	52-81-8348-7383
Puerto Rico	Saltillo	Atlas Industrial Supply, Inc.	52-844-439-3263
	Canovanas	P & C Company	787-768-5033



ACE Controls Inc.
World leader in deceleration technology

23435 Industrial Park Drive Farmington Hills, MI 48335 Phone: 800-521-3320 Phone: 248-476-0213 Fax: 248-476-2470

e-mail: shocks@acecontrols.com www.acecontrols.com