

New Higher Pressure Rating



Swing Check Valve

Standard Features (Sizes 3/4" – 8")

- Minimum flow resistance - Low pressure drop
- Horizontal or vertical installation
- All sizes rated for full vacuum service
- Minimum back pressure to seat disc tightly
- Top access cover facilitates maintenance without body removal from pipeline
- All thermoplastic body
- All PVC parts made of high impact PVC
- PVC and PP Valves come with EPDM seals (Part #'s 5j, 5k, 6 and 7) as standard
- PVDF Valves, Part #'s 5j and 7 of PTFE and 6 of PVDF bonded EPDM
- 3/4" PP Valves supplied with Ring 1a

Options:

- External lever and weight to assist disc in closing faster
- External spring to assist disc in closing faster
- PTFE or FKM Seat and O-Rings



Specifications

Sizes: 3/4" – 8"
Models: Flanged (ANSI) Connection Only
 Lever and Weight Option
Bodies: HI-PVC, PP and PVDF
Seats: EPDM, FKM, PTFE
Seal: EPDM, FKM, PTFE

Parts List (Sizes 3/4" – 8")

PARTS			
NO.	DESCRIPTION	PCS.	MATERIAL
1	Body	1	PVC, PP, PVDF
2	Bonnet	1	PVC, PP, PVDF
3	Shaft	1	PVC, PP, PVDF
4	Bolt	1	PVC, PP, PVDF
5a	Disc	1	PVC, PVDF
5b	Seat Holder	1	PVC, PP, PVDF
5c	Bolt (A)	-	PVC, PP, PVDF
5d	Arm	1	PVC, PP, PVDF
5e	Washer	1	PVC, PVDF
5f	Nut (A)	1	PVC, PVDF
5g	Pin	1	PVC, PVDF
5h	Bolt (B)	1	PVC, PP, PVDF
5i	Nut (B)	1	PVC, PP, PVDF
5j	Seat	1	EPDM, PTFE, Others
5k	O-Ring (A)	1	EPDM, PTFE, Others
6	Gasket (A)	1	EPDM, PTFE, Others
7	Gasket (B)	1	EPDM, PTFE, Others
8	O-Ring (B)	Set	EPDM, PTFE, Others
9	Bolt, Nut, Washer	Set	Stainless Steel 304
1a	Ring	1	Stainless Steel 304

Parts List (Lever and Weight)

PARTS			
NO.	DESCRIPTION	PCS.	MATERIAL
1	Fitting	1	PVC, PP, PVDF
2	Nut	1	PVC, PP, PVDF
3	Shaft	1	Stainless Steel 316
4	Counter Weight	1	PVC
5	Spacer	1	PVC, PP, PVDF
6	O-Ring	1	EPDM, FKM
7	Hex Cap Bolt	Set	Stainless Steel 316
8	Set Screw	1	Stainless Steel 316

Swing Check Valves

PVC&PP
(Elastomeric Seals)

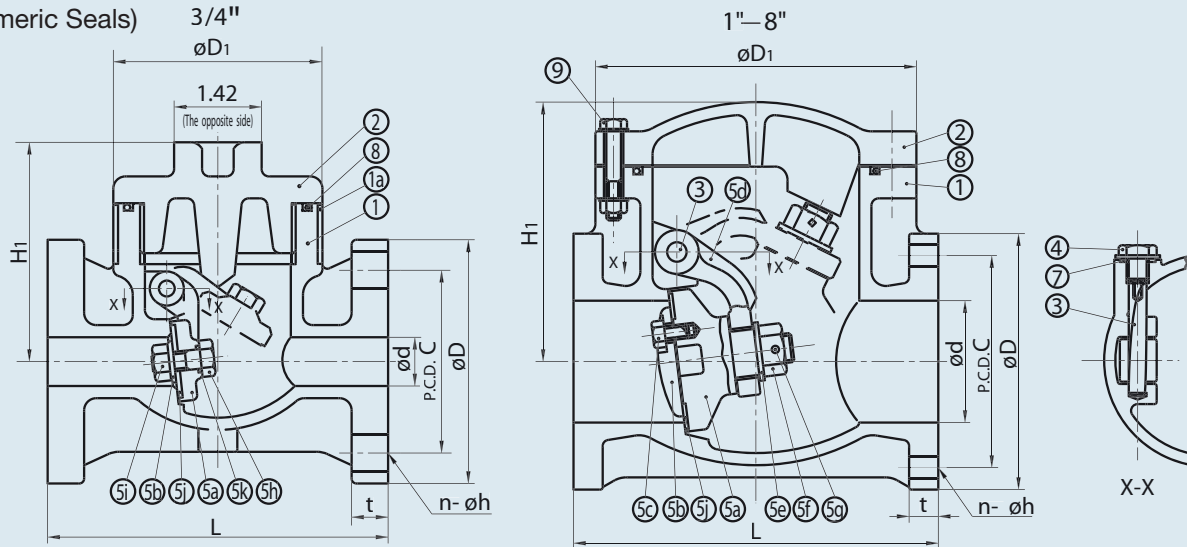

PVDF

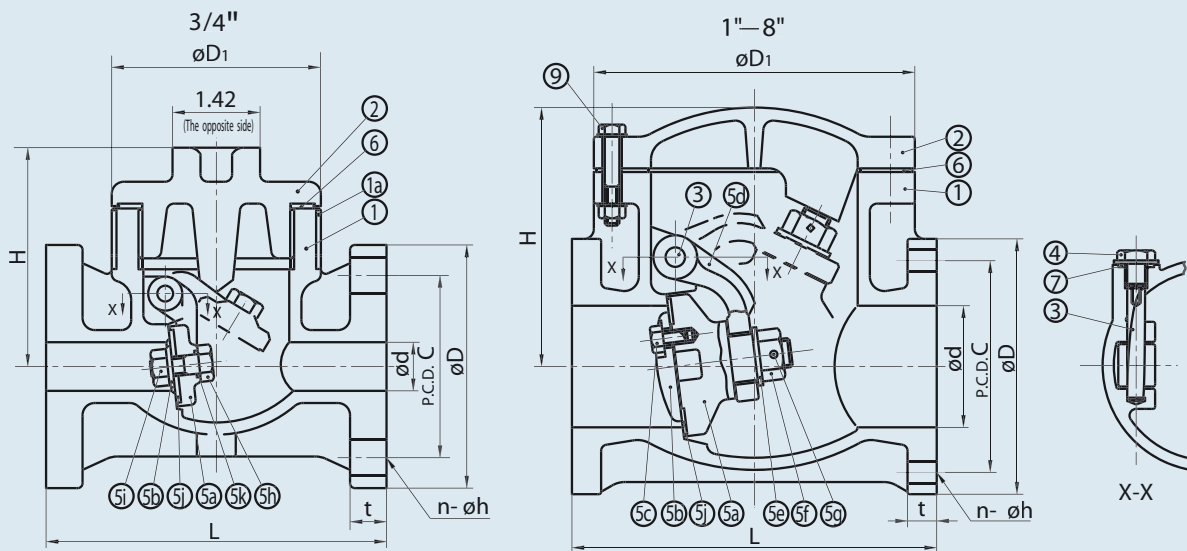

Dimensions (Sizes 3/4" - 8")

NOMINAL SIZE		ANSI CLASS 150					D1	L	t		H1	H
INCHES	mm	d	C	D	h	n			PVC	PP,PVDF		
3/4	20	0.79	2.75	3.88	0.62	4	3.39	5.51	0.59	0.59	3.43	3.54
1	25	0.98	3.12	4.25	0.62	4	5.12	6.30	0.63	0.63	4.61	4.72
1 1/2	40	1.57	3.88	5.00	0.62	4	5.71	7.09	0.71	0.71	5.31	5.43
2	50	1.97	4.75	6.00	0.75	4	7.09	7.87	0.79	0.83	6.34	6.46
2 1/2	65	2.56	5.50	7.00	0.75	4	7.87	9.45	0.87	0.91	6.50	6.61
3	80	3.15	6.00	7.50	0.75	4	8.07	10.24	0.87	0.98	6.61	6.73
4	100	3.94	7.50	9.00	0.75	8	10.43	11.81	0.94	1.02	8.27	8.39
5	125	4.92	8.50	10.00	0.88	8	12.99	13.78	0.94	1.06	9.65	9.76
6	150	5.91	9.50	11.00	0.88	8	14.57	15.75	0.98	1.06	11.02	11.14
8	200	7.87	11.75	13.50	0.88	8	16.73	19.69	1.18	1.34	13.11	13.23

Swing Check Valve

LEVER AND WEIGHT
(OPTION)
PVC, PP, PVDF

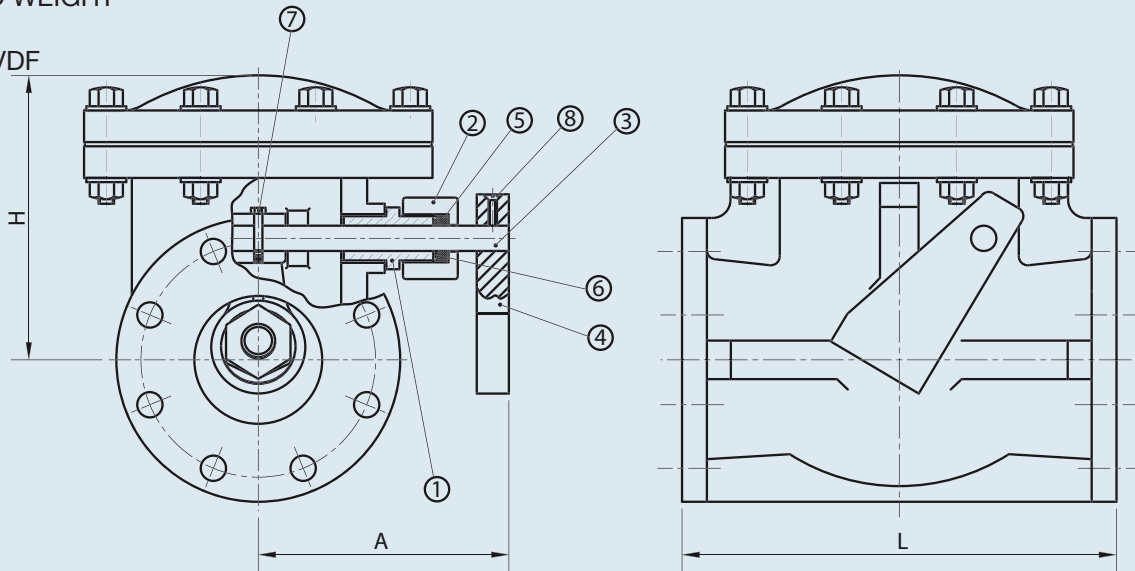

Dimensions (Lever & Weight/External Spring)

NOMINAL SIZE		A	H	
INCHES	mm		PVC,PP	PVDF
3/4	20	4.0	3.43	3.54
1	25	4.5	4.72	4.72
1 1/2	40	5.0	5.43	5.43
2	50	5.5	6.46	6.46
2 1/2	65	6.0	6.61	6.61
3	80	6.5	6.73	6.73
4	100	8.0	8.39	8.39
5	125	10.0	9.76	9.76
6	150	10.5	11.14	11.14
8	200	12.0	13.23	13.23

SPRING ASSIST
(OPTION)
PVC, PP, PVDF

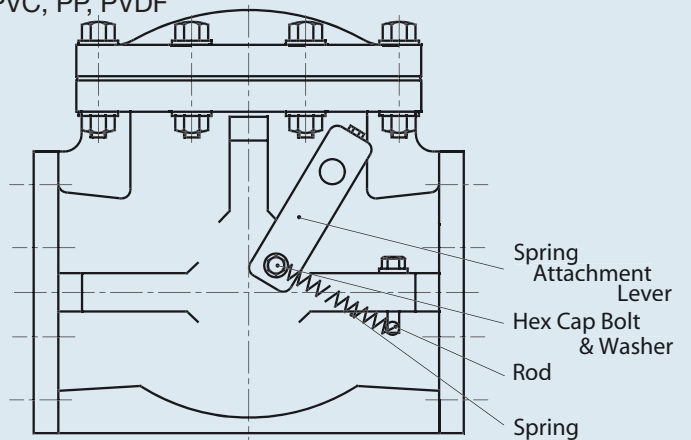

Sample Specification

All Swing Check valves shall be of solid thermoplastic construction, having no metal that comes in contact with media. (Except when Lever & Weight or SS spring option is installed) Valves shall incorporate a single disc design suitable for either horizontal or vertical installations. Valves shall be of top entry bonnet design for maintenance purposes. PVC shall conform to ASTM D1784 Cell Classification 12454-A, PP conforming to ASTM D4101 Cell Classification PP0210B67272 and PVDF conforming to ASTM D3222 Cell Classification Type II. Valves shall be rated to 150 psi sizes 3/4" thru 3", 100 psi sizes 4" thru 6", 75 psi size 8" for PVC or PP with EPDM or FKM seals, 90 psi sizes 3/4" thru 2-1/2", 75 psi sizes 3" & 4", 60 psi size 5" and 45 psi sizes 6" & 8" for PVC with Teflon® seals, 90 psi sizes 3/4" thru 2-1/2", 75 psi sizes 3" & 4", 60 psi size 5" and 45 psi sizes 6" & 8" for PP or PVDF with Teflon® seals all at 70 degrees F, as manufactured by Asahi/America, Inc.

Swing Check Valves

Pressure vs. Temperature (PSI, WATER, NON-SHOCK)

NOMINAL SIZE		PVC			PP				PVDF		
		ELASTOMERS			ELASTOMERS				ELASTOMERS		
		30° F 80° F	81° F 85° F	86° F 120° F	-5° F 85° F	86° F 95° F	96° F 140° F	141° F 175° F	-30° F 140° F	141° F 175° F	176° F 210° F
INCHES	mm										
3/4	20	150	135	100	150	150	100	85	90	75	60
1	25	150	135	100	150	150	100	85	90	75	60
1 1/2	40	150	135	100	150	150	100	85	90	75	60
2	50	150	135	100	150	150	100	85	90	75	60
2 1/2	65	150	135	100	150	150	100	85	90	75	60
3	80	150	135	100	150	150	100	85	75	60	45
4	100	100	100	75	100	90	75	55	75	60	45
5	125	100	100	75	100	90	75	55	60	45	40
6	150	100	100	75	100	90	75	55	45	40	30
8	200	75	75	55	75	65	40	30	45	40	30

Pressure vs. Temperature (PSI, WATER, NON-SHOCK)

NOMINAL SIZE		PVC	PP		PVDF		
		PTFE	PTFE		PTFE		
		30° F 120° F	-5° F 140° F	141° F 175° F	-30° F 140° F	141° F 175° F	176° F 210° F
INCHES	mm						
3/4	20	90	90	75	90	75	60
1	25	90	90	75	90	75	60
1 1/2	40	90	90	75	90	75	60
2	50	90	90	75	90	75	60
2 1/2	65	90	90	75	90	75	60
3	80	75	75	60	75	60	45
4	100	75	75	60	75	60	45
5	125	60	60	45	60	45	40
6	150	45	45	30	45	40	30
8	200	45	45	30	45	40	30

Minimum Back Pressure to Close Valve (PSI)

NOMINAL SIZE		SEAT	
INCHES	mm	ELASTOMERS	PTFE
3/4	20	2.8	5.0
1	25	5.0	8.5
1 1/2	40	5.0	8.5
2	50	5.0	8.5
2 1/2	65	5.0	8.5
3	80	5.7	8.5
4	100	5.7	9.2
5	125	5.7	9.2
6	150	6.4	10.0
8	200	6.4	10.0

Weight

NOMINAL SIZE		LBS.
INCHES	mm	
3/4	20	2.20
1	25	4.40
1 1/2	40	6.61
2	50	10.14
2 1/2	65	14.33
3	80	16.53
4	100	26.45
5	125	44.00
6	150	59.52
8	200	92.59

Cv Values

NOMINAL SIZE		Cv
INCHES	mm	
3/4	20	14
1	25	24
1 1/2	40	81
2	50	140
2 1/2	65	250
3	80	280
4	100	510
5	125	750
6	150	1100
8	200	1900

Troubleshooting

What if valve leaks through the seat?

1. Sediment build-up around disc and seat. Clean disc and seat.
2. Disc or seat broken or damaged. Replace disc or seat.
3. Insufficient back pressure. Check the pressure.

What if valve leaks between bonnet and body?

1. Bolts not tightened properly. Tighten firmly per specified torque.
2. Seal chemically attacked or worn. Replace seal.
3. Exceeds maximum allowable pressure rating