



Multiport® Ball Valve Type 23

Standard Features (Sizes 1/2" – 6")

- True Union design on all three ports
- Double O-ring seals on stem for added protection
- Integrally molded ISO mounting pad for both manual and actuated operations
- Blow-out proof, solid mold bottom entry design
- Blocks from left or right union ports, leaving full pressure on the opposite end of valve
- Standard "L" port ball permits flow from common port to either left or right port or to "OFF" position
- PTFE seats with elastomeric backing cushions ensure bubble-tight shut-off and a low fixed torque, while at the same time compensating for wear
- Built-in spanner wrench on the handle for valve disassembly and assembly
- All sizes rated for full vacuum service
- Eliminates need for additional valve and "Tee"

Options

- Pneumatic and electric actuators & accessories
- Stem extensions
- 2" square operating nut or "T" nut
- Locking handles
- Limit switches
- "T" port, Double "L" port

Cross Port Ball Options (1/2" - 2" only)

- 4 different flow patterns through 3 separate ports are possible because of the crossed flow patterns within the ball
- Changing position of handle changes flow pattern. Handle rotates 360°

Specifications

- Sizes:** 1/2" – 6"
Models: PVC & CPVC: Socket, Threaded and Flanged (ANSI)
Bodies: PVC, CPVC, PP, PVDF
Seats: PTFE backed with EPDM or FKM
Seals: EPDM or FKM or AFLAS®†

Sizes 1/2" - 4" PVC/EPDM/FKM Models
 NSF-61 Certified

† Trademark of Asahi Glass Co., Ltd.

Parts List (Sizes 1/2" – 6")

PARTS			
NO.	DESCRIPTION	PCS.	MATERIAL
1	Body	1	PVC, CPVC, PP, PVDF
2	Ball	1	PVC, CPVC, PP, PVDF
3	Carrier	2	PVC, CPVC, PP, PVDF
4	End Connector	3	PVC, CPVC, PP, PVDF
5	Union Nut	3	PVC, CPVC, PP, PVDF
6	Stem	1	PVC, CPVC, PP, PVDF
7	Seat	2	PTFE
8	O-Ring (A)	3	EPDM, FKM, Others
9	O-Ring (B)	2	EPDM, FKM, Others
10	Cushion*	2	EPDM, FKM, Others
	O-Ring (C)**		
11	O-Ring (D)	1	EPDM, FKM, Others
12	O-Ring (E)	1	EPDM, FKM, Others
13	Stop Ring***	3	PVDF
14	Handle	1	ABS
15	Screw	1	304 Stainless Steel
4a	Ring****	3	304 Stainless Steel

* Used for size 1/2" – 2", ** Used for size 3" and 4"

*** Used for flanged end

**** Used for CPVC body, threaded end, 1/2" – 1"



Type 23

Multiport® Ball Valves

FLANGED END ("L" PORT: STANDARD)

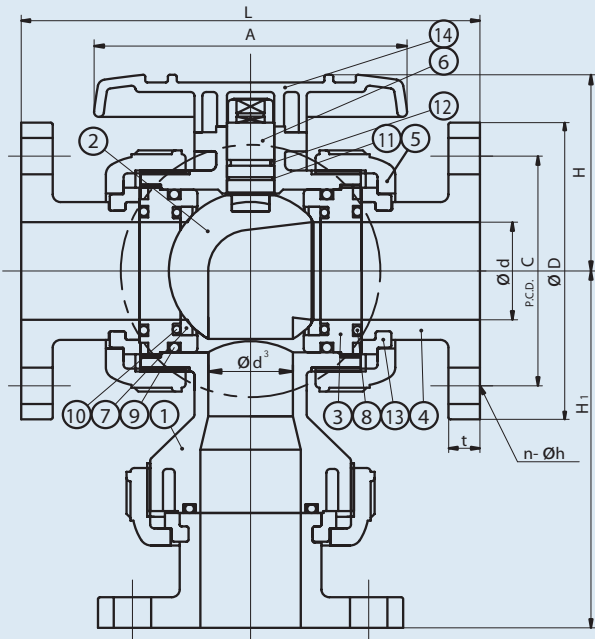

3" & 4"

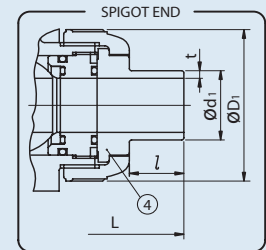
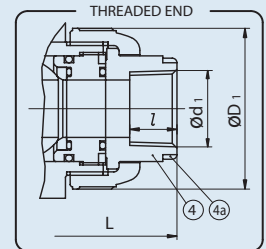
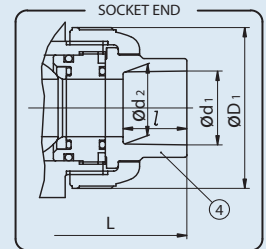
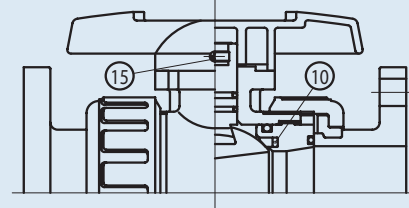

DOUBLE "L" PORT DETAIL

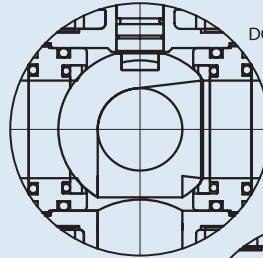

CROSS PORT DETAIL

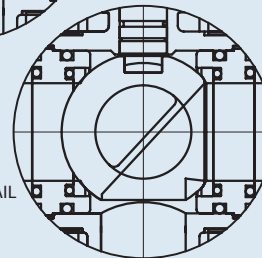

Dimensions (Sizes 1/2" - 4") For 6" size consult factory.

NOMINAL SIZE		FLANGED									THREADED						
		ANSI CLASS 150									PP, PVDF (IPS)						
INCHES	mm	d	d ³	D	C	n	h	L	t	H ₁	d ₁	l	L	H ₁	d ₁	l	t
1/2	15	0.59	0.59	3.50	2.38	4	0.62	5.63	0.47	3.70	1/2-14 NPT	0.59	4.02	2.89	1.89	2.03	3.62
3/4	20	0.79	0.79	3.88	2.75	4	0.62	6.77	0.55	4.50	3/4-14 NPT	0.67	4.72	3.48	2.36	2.34	3.94
1	25	0.98	0.98	4.25	3.12	4	0.62	7.36	0.55	5.24	1-11 1/2 NPT	0.79	5.16	4.13	2.76	2.68	4.33
1 1/2	40	1.57	1.26	5.00	3.88	4	0.62	8.35	0.63	6.50	1 1/2-11 1/2 NPT	0.98	6.42	5.53	3.94	3.50	5.16
2	50	2.01	1.69	6.00	4.75	4	0.75	9.21	0.63	7.34	2-11 1/2 NPT	1.10	7.76	6.61	4.96	4.04	6.26
3	80	3.07	2.70	7.50	6.00	4	0.75	11.97	0.71	10.06	3-8 NPT	1.38	10.39	9.25	5.98	5.51	9.45
4	100	3.94	3.54	9.00	7.50	4	0.75	14.65	0.71	12.01	4-8 NPT	1.77	14.17	11.77	8.27	7.01	12.01

NOMINAL SIZE		SOCKET													SPIGOT (BUTT END)										
		PVC, CPVC						PP, PVDF (DIN)						PP, PVDF (IPS)						PP, PVDF					
		ANSI SCH 80/40						DIN 16962												DIN 3442					
INCHES	mm	d ₁	d ₂	l	L	H ₁	d ₁	d ₂	l	L	H ₁	d ₁	l	L	H ₁	d ₁	l	t	t	L	H ₁				
1/2	15	0.848	0.836	0.875	4.45	3.08	0.768	0.760	0.57	3.90	2.80	0.83	0.87	4.45	3.09	0.787	0.728	0.098	0.075	4.88	3.27				
3/4	20	1.058	1.046	1.000	5.08	3.56	0.965	0.957	0.63	4.49	3.27	1.03	1.00	5.08	3.61	0.984	0.866	0.106	0.075	5.67	3.90				
1	25	1.325	1.310	1.125	5.75	4.32	1.240	1.232	0.71	4.84	3.94	1.30	1.13	5.75	4.37	1.260	0.886	0.118	0.094	6.06	4.53				
1 1/2	40	1.912	1.894	1.375	7.24	5.71	1.947	1.937	0.93	5.83	5.16	1.89	1.37	7.24	5.85	1.969	1.260	0.181	0.118	6.85	6.02				
2	50	2.387	2.369	1.500	8.23	6.66	2.461	2.445	1.08	6.93	6.06	2.36	1.50	8.23	6.76	2.480	1.417	0.228	0.118	8.82	7.01				
3	80	3.516	3.492	1.875	11.10	9.59	3.512	3.498	1.40	9.88	8.82	3.48	1.87	11.10	11.10	3.543	1.496	0.323	0.169	11.61	9.69				
4	100	4.518	4.491	2.000	13.90	11.58	4.293	4.278	1.63	12.20	10.98	4.48	2.25	14.37	14.37	4.331	1.752	0.394	0.209	12.72	11.85				

Type 23

Multiport® Ball Valves

Pressure vs. Temperature (PSI, WATER, NON-SHOCK)

NOMINAL SIZE		PVC			CPVC				PP			PVDF			
		30° F 70° F	71° F 105° F	106° F 120° F	30° F 120° F	121° F 140° F	141° F 175° F	176° F 195° F	-5° F 85° F	86° F 140° F	141° F 175° F	-5° F 140° F	141° F 175° F	176° F 195° F	196° F 210° F
INCHES	mm														
1/2-2	15-50	150	150	150	150	120	85	55	150	90	60	150	120	110	85
3-4	80-100	150	150	150	150	85	55	45	150	75	45	150	100	85	70

Available Flow Patterns

L-Port

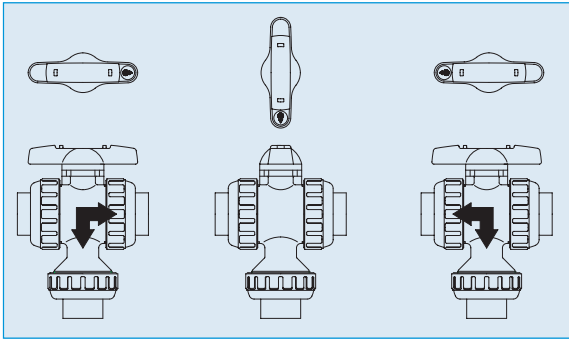

Double L-Port

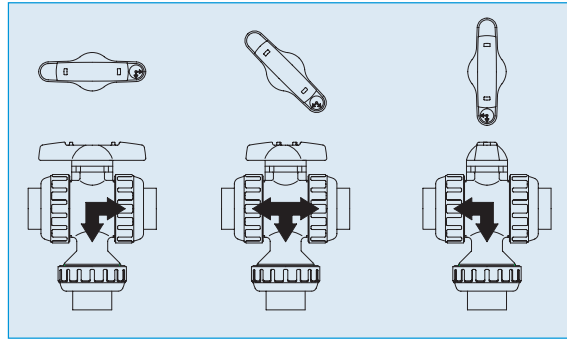

T-Port

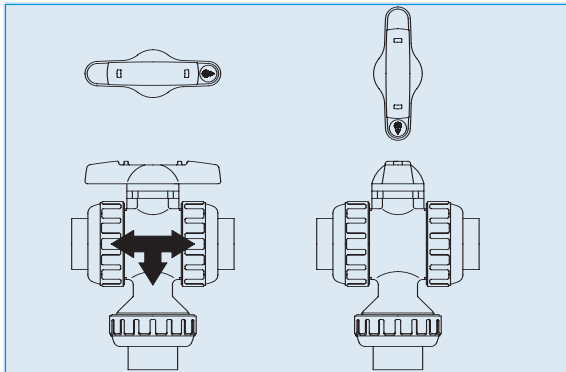

Cross Port (1/2" - 2" only)

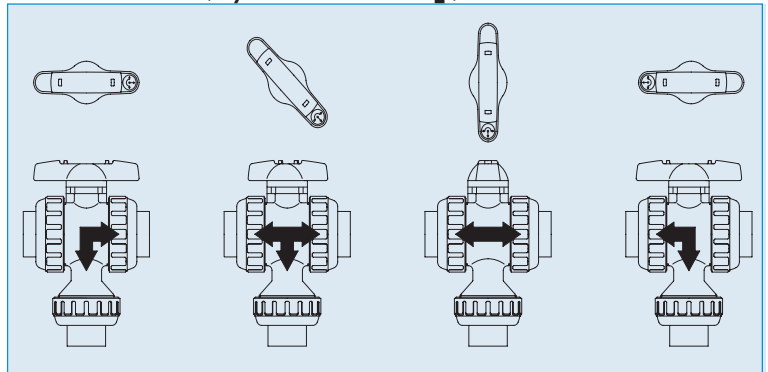

Automation

For Pneumatic Actuation:

"Double L-Port" ball is supplied as a standard feature. Other configurations available as options. Pneumatic actuators are 2 position, 90° Rotation.

For Electrical Actuation:

"L-Port" ball is supplied as a standard feature. All other ball configurations are available as options. Electrical actuators are 2 position, 180° Rotation with the option for a third "Center" position.

Type 23

Multiport® Ball Valves

Sample Specification

All Type 23 Multiport ball valves shall be of molded thermoplastic construction with union end on all three ports. Carriers must thread into the body in order to provide blocking capabilities in OFF position. Stem shall have double O-Rings and be of blow out proof design. The valve handle shall double as carrier removal and/or tightening tool. ISO mounting pad shall be integrally molded to valve body. PVC conforming to ASTM D1784 Cell Classification 12454-A, CPVC conforming to ASTM D1784 Cell Classification 23567-A, PP conforming to ASTM D4101 Cell Classification PPO210B67272 and PVDF conforming to ASTM D3222 Cell Classification Type II. The valves shall be rated to 150 psi at 70° F. PTFE seats must have elastomeric backing cushion of the same material as the valve seals, as manufactured by Asahi/America, Inc.

Caution

- Never remove valve from pipeline under pressure.
- Always wear protective gloves and goggles.
- Watch out for trapped fluid in valve.
- Only L-port and T-port valves are closed when Handle is positioned perpendicular (90 degrees).
- Even if handle is perpendicular, valve is not closed if the ball is in the following positions, based upon the following porting configurations:
 - (a.) *Double L-Port* – Flow is to right or left
 - (b.) *Cross-Port* – Flow is horizontal as in regular ball valve.

Troubleshooting

What if the fluid still flows when valve is closed?

1. Carrier is not properly tightened. Tighten it firmly.
2. PTFE seat is damaged or worn. Replace seat.
3. Foreign material is caught between ball and PTFE seat. Remove material and clean.
4. Ball is damaged or worn. Change ball.

What if fluid leaks between body and nuts?

1. Carrier or face O-ring is damaged, worn, or missing. Replace O-ring.

What if stem leaks?

1. Stem is damaged. Replace stem.
2. O-ring is damaged. Replace O-ring.

What if handle does not rotate smoothly?

1. Foreign material has formed on the ball or seat. Clean both.
2. Internal part(s) chemically attacked or swollen. Refer to Asahi/America Chemical Resistance Chart for compatibility. Replace part(s) as required.
3. Carrier over-tightened. Tighten properly.

What if handle rotates too freely?

1. Stem is damaged. Replace stem.
2. Handle is not engaged with stem. Disassemble and reengage. Inspect.

Cv Values

NOMINAL SIZE		Cv	
INCHES	mm	L-PORT	DBL-L
1/2	15	7.4	6.3
3/4	20	10	8.5
1	25	23	20
1 1/2	40	43	36
2	50	59	45
3	80	130	99
4	100	260	200

Weight (POUNDS)

NOMINAL SIZE		SOCKET THREADED	FLANGED
INCHES	mm		
1/2	15	0.66	1.76
3/4	20	1.10	2.42
1	25	1.76	3.52
1 1/2	40	4.18	6.36
2	50	5.73	8.59
3	80	15.43	18.95
4	100	35.27	39.90