

Improve Workflow...Increase Productivity and Profits with Bunting Material Handling Systems and Tools

Bunting Material Handling Equipment...The Perfect Fit For Your Plant

If you work with metal, Bunting Magnetics has tools and systems to make your operation more productive and more profitable. We offer a wide variety of products for the metalworking industries – from simple electromagnets that hold ferrous material for faster machining or assembly to devices that stack or unstack ferrous parts and move them from station to station with precise timing and placement.

Our Material Handling Products save time, labor, and expense in a wide range of industrial applications. Bunting engineers can integrate appropriate technology within your plant to improve material handling, speed up assembly and production, and reduce labor and maintenance costs.

At every point where you handle or fabricate ferrous materials, we have innovative magnet-based tools and automated systems that enable you to run your operation more smoothly, safely, and efficiently.



Standard Models – Plus Custom Solutions

Whether you are planning a plant-wide update or streamlining a specific operation, we can supply standard tools and modules or design and build custom “packages” to meet your objectives. Our magnetic components and systems can be integrated into new or existing production lines that use material handling equipment and controls from other manufacturers. Our magnetic Stacking/Destacking and Timing Belt Conveyor Modules are built from the ground up to fit your application and plant layout – each installation is engineered to match your specific needs. Whatever you require, you get single-source convenience and single-source responsibility. We offer engineering assistance and manufacturing capabilities that can deliver everything from pre-engineered modular conveyors to completely customized installations.



On the following pages, you'll see some of our most widely used material handling products and discover what they can do for you. To see more photographs, equipment drawings, and specifications, we invite you to visit our web site at www.buntingmagnetics.com or request product catalogs. For more complete and detailed information, call us toll free at 1-800-835-2526 (outside the U.S. and Canada 1-316-284-2020) and ask to speak with a material-handling specialist to get the full story on moneysaving tools for your trade.

CONTENTS PAGES

INTRODUCTION 2

THE PERFECT METALWORKING PLANT™ 4-5

**STANDARD PRE-ENGINEERED
MAGNETIC CONVEYORS 6-7**

MAGNETIC CONVEYOR COMPONENTS 8-9

LOW-PROFILE CONVEYORS 10

HEAVY-DUTY LOW-PROFILE CONVEYORS 11

MEDIUM-FRAME CONVEYORS 12

CAN CONVEYORS 13

**STACKING/DESTACKING & TIMING BELT
CONVEYORS 14-15**

MAGSLIDE® BELTLESS CONVEYORS 16-17

MAGNETIC SHEET FANNERS 18

MAGNETIC LAWNCHAIR CONVEYORS 19

CUSTOM MAGNETIC CONVEYING SYSTEMS . . . 20-21

**POWERTRAC® ALUMINUM FRAME
CONVEYORS 22-23**

“MOVE-IT”™ SYSTEMS CONVEYORS 24-25

GRINDER/SHREDDER FEED CONVEYORS 26-27

PERFECT METAL WORKING PLANT™

LET BUNTING ENGINEERS HELP YOU PLAN THE PERFECT PLANT

We have one of the most extensive conveyor lines in the industry. Our Standard Frame Conveyors are modular in design so that you can assemble complete conveying systems quickly and economically from pre-fabricated sections. Bunting compact Low-Profile Conveyors and trim Medium Frame Conveyors handle tight spaces and tough jobs. Our beltless MagSlide® Conveyors stand up to highly abrasive scrap and parts. Versatile PowerTrac® Conveyors have V-guide belts and strong aluminum frames custom fit to your operation.

Our Portable “Move-It”™ Conveyors go where you need them. Grinder/Shredder Feed Conveyors help remove metal debris from plastics recycling applications. Our Magnetic Conveyor Components convert ordinary belt conveyors into efficient magnetic conveyors. Bunting automated Stacking/Destacking and Timing Belt Conveyors feed your production machinery, index for precise positioning, and stack or deliver parts to the next workstation.

Bunting Electromagnets, Magnetic Lifters, Sheet Fanners, and Workholding Tools make handling ferrous parts and sheet stock easier, faster, and safer. Our Bunting Magnetic Sweepers are the fast, safe, economical way to clean up metal debris. For information on these products please request our Magnetic Materials and Assemblies catalog #3000.

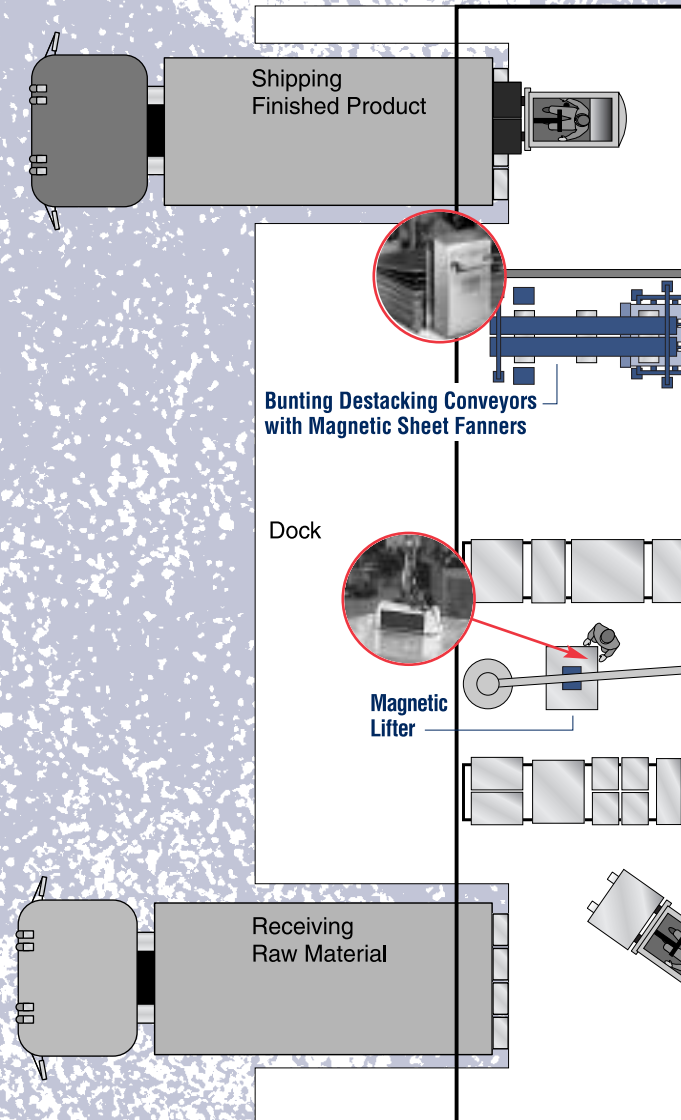

CUT TO LENGTH LINE

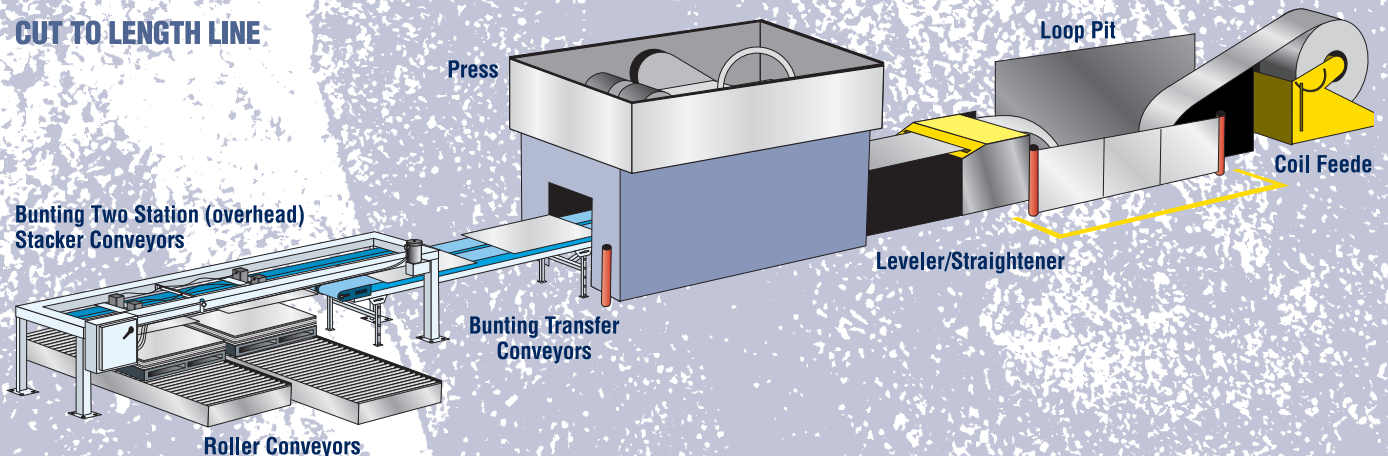

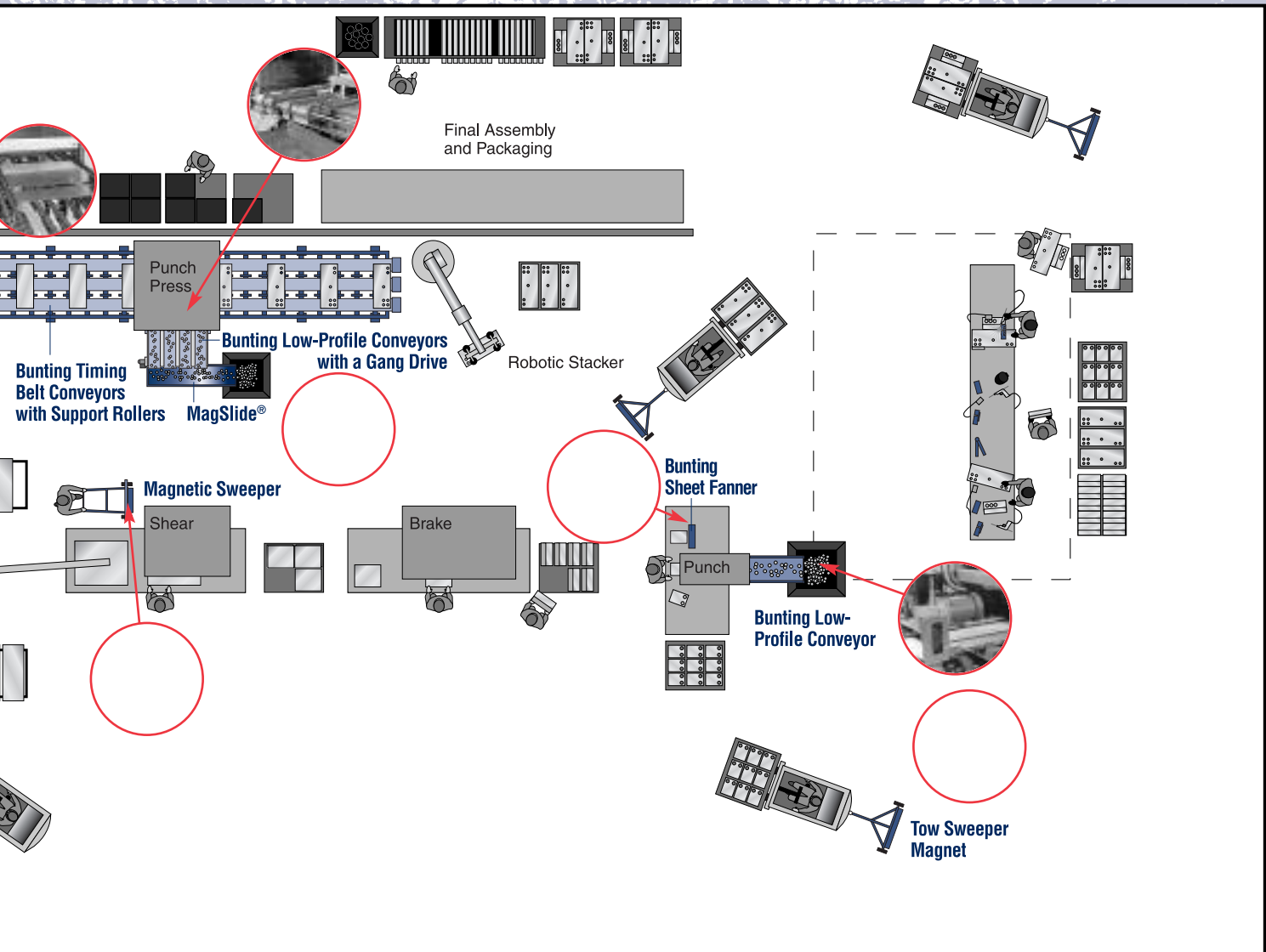

DESTACKING-PUNCH OR FORM-STACKING LINE

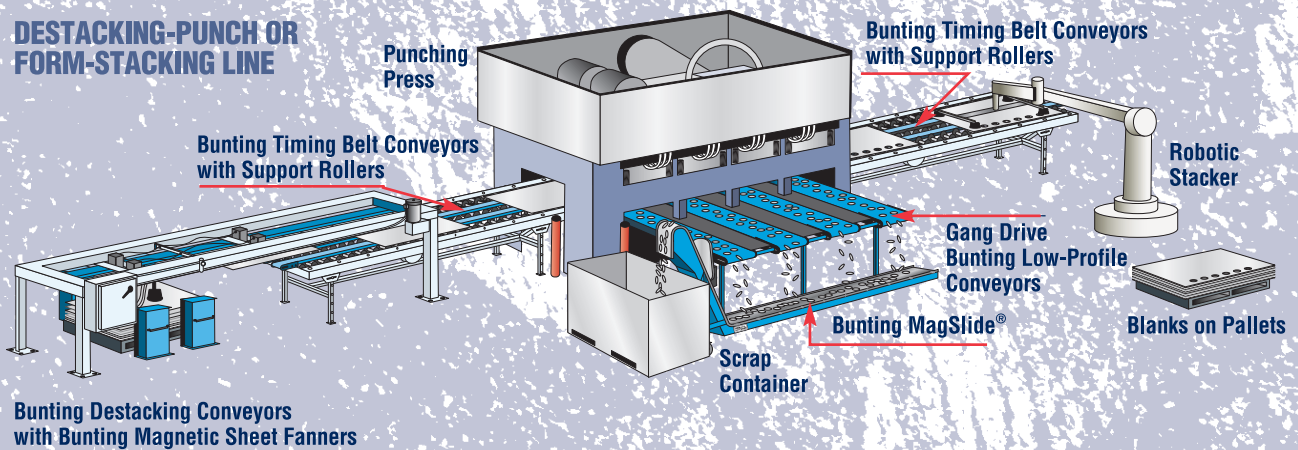

STANDARD PRE-ENGINEERED MAGNETIC CONVEYORS FOR CUSTOM SOLUTIONS WITH MODULAR ECONOMY AND CONVENIENCE

Bunting Pre-Engineered Standard Frame Magnetic Conveyors offer low cost, low maintenance, and compatibility with other conveying equipment and production lines – including production lines that use material handling equipment and controls from other manufacturers.

Our Pre-Engineered Magnetic Conveyors come in modular sections that enable you to configure a complete conveying system quickly and economically. The number, size, strength, and reach-out of your conveyor's



Ceramic or Rare Earth magnetic elements can be matched to your application. They can handle just about any wholly or partially ferrous product that can be transported on a conveyor and many types of ferrous scrap.

Modular construction simplifies assembly, installation, and maintenance. Standard Frame Conveyors can be up and running in surprisingly little time.

They give you control of spacing, sequence, position, elevation, and release points. Standard modules can be combined with custom conveyors and custom conveying systems to reduce initial costs and save construction expense. Bunting's engineering staff will be glad to assist you in designing a system that fits your needs, budget, and plant layout.



Bunting offers the options you need for a complete custom engineered solution

- Select straight and curved sections, floor mounts, and ceiling hangers to match your layout.
- Order drives, magnets, and belts suited to your materials.
- Choose accessory hoppers, chutes, and guide rails to collect and feed parts where you want them.
- Move ferrous materials up, over, and around production machinery.
- Elevate parts on inclines up to 90 degrees.
- Convey materials overhead to save valuable floor space.
- Keep material flow jam free.
- Stabilize even irregularly shaped parts.
- Maintain spacing, orientation, and feed rate for orderly delivery to production machinery.
- Keep finished parts free of scratches and other impact damage.
- Safely and continuously remove scrap.

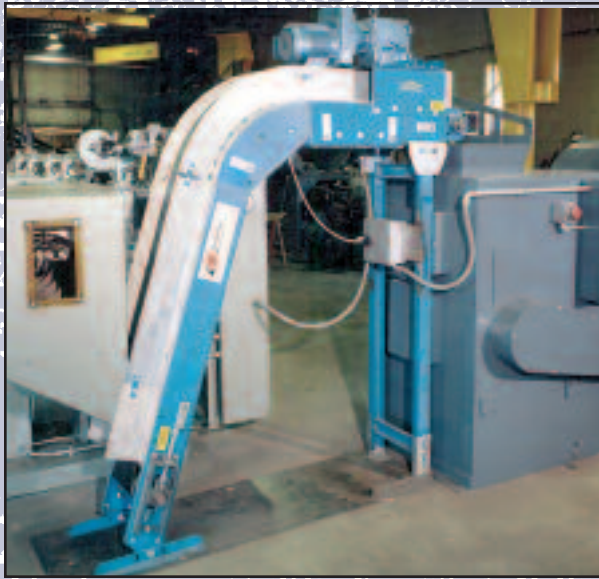

Standard Pre-Engineered Magnetic Conveyors

MAGNETIC CONVEYOR COMPONENTS TO MAKE OR MODIFY YOUR SYSTEM

Retrofit or Design Your Own Conveyor

Our wide selection of Permanent Magnetic Conveyor Components includes everything you need to design your own system from the ground up or to modify and *magnetize* an existing belt conveyor system. With these components you can capture, stabilize, space, sequence, turn, lift, separate, and feed materials, parts, and assemblies. In short, you can achieve essentially the same control

provided by factory-built units. You get the same proven Bunting conveyor components that we use in many of our own conveyors and that we sell to OEMs.

We even offer an all-stainless-steel test bath conveyor to carry pressurized products such as aerosol cans through liquid baths to check for gas leaks.

Magnetic Drive Rollers

Magnetic Drive Rollers and Drive Roller Assemblies are engineered for trouble-free, efficient handling of sheet stock ranging from .010-inch tin plate to sheets over 1/4-inch thick. Mild steel pole pieces and stainless steel encased magnets result in a highly scratch- and nick-resistant drive surface for moving and controlling ferrous sheets. Recessed areas between pole pieces collect metal fines to help keep contact surfaces scrap-free.

Magnetic Pulleys

Magnetic Pulleys can be used with Magnetic Take-Off Rails to separate ferrous debris from conveyed material. They are also used to turn over ferrous parts and feed them into machinery.

Magnetic Plate Rails

Magnetic Plate Rails are used in applications where high magnetic strength is required. They mount behind conveyor belts and provide the holding force that keeps ferrous parts in place as belts move them to their destination.

Magnetic Channels

Magnetic Channels are used where space is limited and where high magnetic strength is not required.

Magnetic T-Rail Straight Sections

T-Rail Straight Sections come in a variety of sizes and 3 magnetic strengths to hold parts on moving belts.

Magnetic Curved Sections

Magnetic Curved Sections are available in both Plate Rail and T-Rail configurations which dimensionally and magnetically mate with Straight Sections and come in the same widths and magnetic strengths.

Magnetic Take-Off Rail Assemblies

Magnetic Take-Off Rail Assemblies are designed with gradually decreasing magnetic force along their length to remove ferrous material from the conveyor's magnetic field. They are often used with wider Magnetic Pulleys.

UP-STACKER PULLEYS REORIENT ROUND FLAT DISKS

Up-Stacker Pulleys position flat circular ferrous parts for further processing. The Up-Stacker's magnetic field and surface contour are designed to orient such parts radially around the pulley. Metal disks fed from a horizontal conveyor to an Up-Stacker Pulley reposition themselves for stacking or other

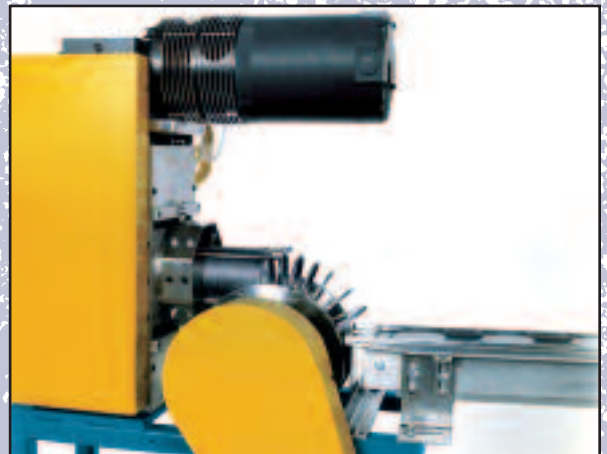

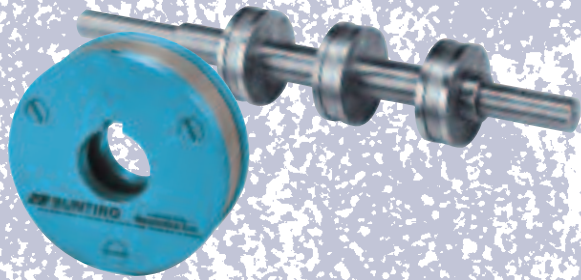

Magnetic Drive Rollers

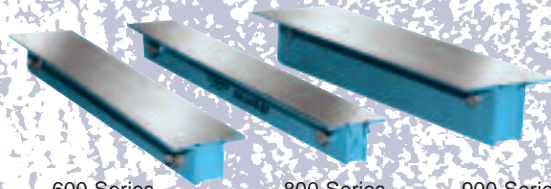

600 Series 800 Series 900 Series
Magnetic T-Rail Straight Sections



Magnetic Pulleys

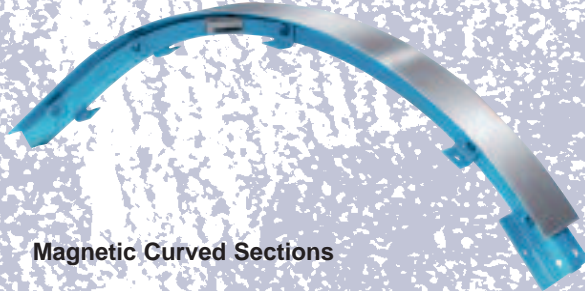

Magnetic Curved Sections

700 HD Series

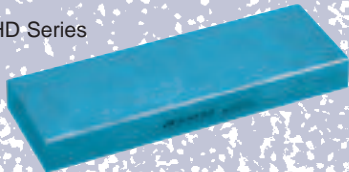

700 XHD Series



Magnetic Plate Rails

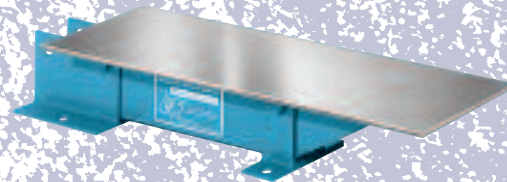

Magnetic Take-Off Rail Assemblies

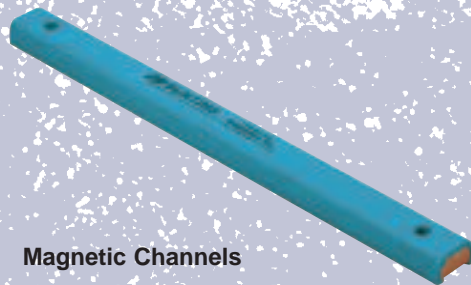

Magnetic Channels

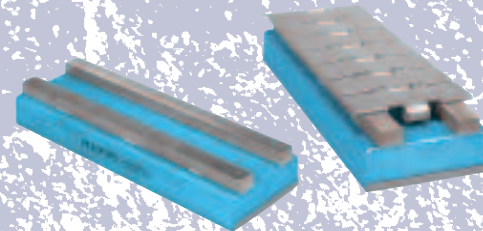

BM700HD Special with Lugs

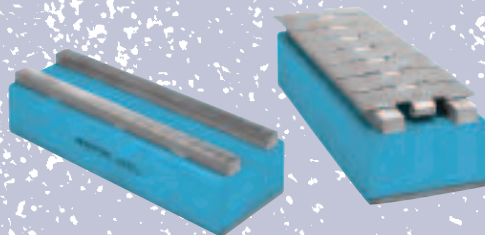

BM700XHD Special with Lugs

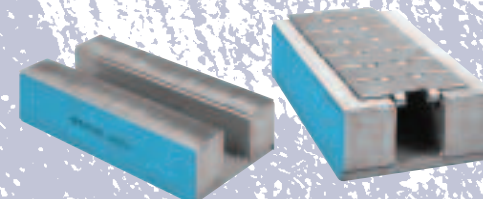

Aerosol Test Bath Rails

STANDARD-DUTY LOW-PROFILE CONVEYORS

Transfer Parts and Remove Scrap from Under Press and Other Tight Spaces

Compact Bunting Low-Profile Conveyors need less than 2 inches of vertical clearance to remove parts and scrap from punch presses and from other confined spaces. They fit a wide range of applications that preclude the use of conventional conveyors. Where several Low-Profile Conveyors are installed in tandem, a single motor can provide gang drive power. Standard models are magnetic to provide continuous control of small-to-medium size ferrous parts and scrap. But both magnetic and nonmagnetic models reduce labor costs, minimize downtime, and increase productivity.



- Compact profile requires just 1 11/16-inch vertical clearance to fit where other conveyors cannot.
- Formed channel body frame is made from 11-gauge stainless steel.
- Standard widths range from 2 to 12 inches. Lengths from 1 to 10 feet.
- Standard endless urethane belts are oil-, puncture-, and abrasion-resistant. Belts are available in other materials and with cleats.
- Belts travel up to 120 fpm at constant or variable speeds.
- All-steel, crowned-face drive pulley measures 1 9/16-inch and has knurled surface for added traction.
- Bunting's exclusive Full-Width Magnetic Platen holds parts and scrap in place across the entire width of the belt.
- Magnetic element provides decreasing force at each end of conveyor for smooth product release.
- Quick-change belt design minimizes downtime for belt replacements and allows for easy on-line tension and tracking adjustments.
- Options include individual and gang drives, specialized belts, floor supports, and side guards.
- Reliable small parts transfer conveyor.

HEAVY-DUTY LOW-PROFILE CONVEYORS

Handle part and scrap removal in high-speed, heavy-load, and other demanding applications

When you need a conveyor designed to handle the toughest under-press jobs day after day with minimum maintenance, Bunting's Heavy-Duty Low-Profile Conveyor is the right choice. The rugged frame and components are built for extra-heavy loads, high belt speeds, and applications where heavily oiled parts and scrap are conveyed. Formed-channel outer body is 11-gauge CRS with 16-gauge stainless steel formed-channel slider bed. For extra traction, there's an extra-large 3 1/2 -inch drive pulley.

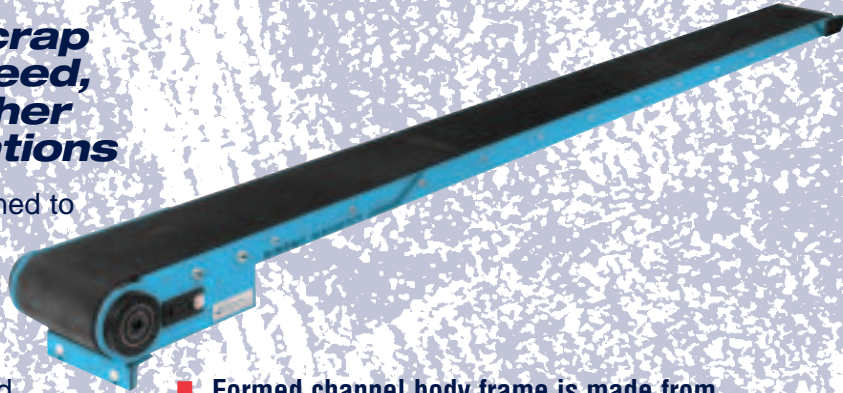

- Formed channel body frame is made from 11-gauge CRS with 16-gauge stainless steel formed channel slider bed. Drive panel is 3/16" CRS for extra rigidity.
- Compact profile requires just 1 11/16-inch vertical clearance — fits where other conveyors cannot.
- Standard widths range from 2 to 12 inches. Lengths from 18 inches to 10 feet.
- Standard endless urethane belts are oil-, puncture-, and abrasion-resistant. Belts are available in other materials.
- HD belts travel at constant or variable speeds up to 250 fpm.
- Robust, crowned-face 3 1/2-inch drive pulley has knurled surface for added traction.
- Bunting's exclusive Full-Width Magnetic Platen holds parts and scrap in place across the entire width of the belt.
- Magnetic element provides decreasing force at each end of conveyor for smooth product release.
- Quick-change belt design minimizes downtime for belt replacements and allows for easy on-line tension and tracking adjustments.
- Options include individual and gang drives, specialized belts, floor supports, and side guards.

Medium-Frame Conveyors

MEDIUM-FRAME CONVEYORS BRIDGE THE GAP BETWEEN LOW-PROFILE AND STANDARD FRAME CONVEYORS

Bunting Medium-Frame Conveyors come in magnetic and nonmagnetic models and offer the added options of portability plus adjustable height and incline. The rugged MFC frame is only 3 1/2" high and just 2 3/4" wider than the conveyor belt, so these conveyors can fit where space is limited and handle a broad range of jobs. Belt widths range from 2 to 36 inches, conveyor lengths from 2 to 12 feet and more. Like other Bunting conveyors, they can be equipped with a variety of magnetic elements for positive control of different weights and shapes of parts. For stationary use, Medium-Frame Conveyors are offered as fixed-base units.

- **Medium height frame lets you handle big jobs where space is limited.**
- **Frame design gives you more working width to convey larger parts.**
- **Set constant or variable belt speeds up to 250 fpm.**
- **Heavy-duty frame, pulleys, rollers, and take ups handle demanding applications.**
- **Mobile base available with adjustable incline for added versatility.**
- **Build your MFC with an exceptionally wide choice of options.**
- **Select drive motor, belt, and magnet strength to fit your requirements.**



CAN CONVEYORS

Bunting Magnetic Can Conveyors move and control full and empty cans safely and efficiently. They are designed to convey today's thinner-walled cans without damage and to eliminate the downtime associated with grippers and other mechanical handling devices.

Our Can Conveyors use powerful Bunting magnetic plate rails to hold cans against the conveyor belt while non-marring can guides stabilize cans as they are elevated, lowered, or simply conveyed horizontally by the motor-driven belt. They are engineered to withstand the punishment of high-capacity systems in both wet and washdown environments.

Bunting Can Conveyors are built for optimum moisture control and corrosion resistance. The open-top frame design channels water to the inside of the frame, and optional drip covers can be used to prevent water from dripping down to floor

- **Conveyors are available for both wet and washdown service.**
- **Powerful plate rail magnets are tailored to your application.**
- **Structural rigidity allows long, unsupported, space-saving runs.**
- **Belting options match a wide range of applications.**



AUTOMATED MAGNETIC CONVEYING SYSTEMS STACK, DESTACK, AND TRANSFER SHEET STOCK

Increase Production Capacity and Efficiency

Bunting brings the economy, reliability, and safety of dependable permanent magnet power to the automated handling of ferrous stock, parts, and scrap. Designed to boost production capacity and cut handling costs, Bunting Magnetic Conveying Systems can easily be adapted to a wide range of applications. Our engineers use the latest computer-aided design technology and CNC production techniques to “custom fit” our automated conveyors and integrate them into new or existing lines. They can be configured to transport, stack, and destack a wide variety of ferrous materials in many shapes and sizes. Whether you are planning plant-

wide automation or just streamlining a specific operation, we can design what you need, including all necessary switches, drives, electronic controls, and high-capacity conveyors.

- **Control transfer of sheets and blanks.**
- **Feed machines for optimum utilization.**
- **Stack parts, transfer parts, and feed presses.**
- **Control speed and direction of travel.**
- **Control part spacing and position.**
- **Accumulate and move parts into storage.**
- **Destack parts to feed presses.**

Bunting Stacking/Destacking Conveyors Reduce Production Bottlenecks

Bunting Permanent Magnetic Stacking/Destacking Conveying Systems move sheet metal components to and from existing conveyors, punch presses, stamping or blanking operations, and other production machinery. They transfer, index, and stack the sheet metal components at preselected destination points, and they can be configured to destack sheets ready for the next stage of production.

Powerful permanent magnets inside these conveyors securely hold each ferrous sheet

while it is transported to the stacking point. There, the sheet triggers a sensor that activates a rotary magnetic switch or permanent electro magnet to release the sheet above the stacking area. The magnetic switch returns to its initial position upon release of the sheet, ready to convey and stack the next part. The released parts can be stacked on a pallet, conveyor, or other surface, in any desired quantity. Rejected parts can be conveyed to a separate location.

Timing Belt Conveyors Position and Index Sheets and Blanks

Bunting Timing Belt Conveyors give you the advantage of precise speed control. Work pieces stay synchronized with production line operations and robotics. These conveyors let you process parts as they are being conveyed and allow indexing and multiple pick-up options. Precise conveyor belt timing maintains the spacing of sheets, blanks, and parts from initial placement on the conveyor until they are removed by robotic devices, transferred to another conveyor, or stacked.

Sheets touch only the conveyor belts, avoiding damage to delicate parts and finished surfaces. Painted or oily parts require no special handling. Permanent magnets never wear out and won't send parts flying or create jams during power failures. Material handling time is greatly reduced. With fast, automated sheet handling, production machinery can be used more efficiently. Consequently, production costs per unit drop significantly.



Sheet Stacker Drive (side view)

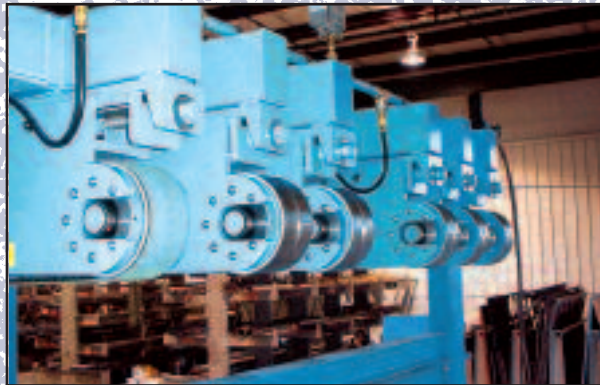

Take Ups

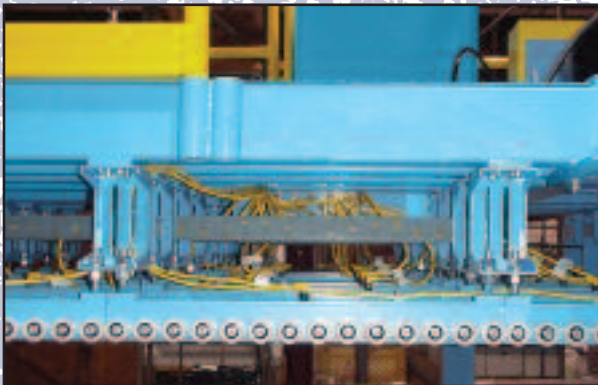

Stacker Permelectro Circuitry

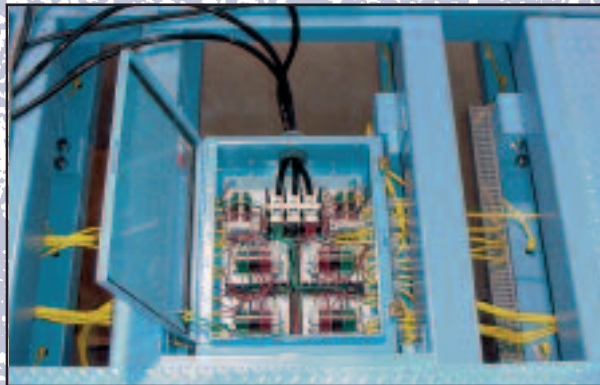

Junction Box



Sheet Stacker Drive (end view)



Cinch Roller

MAGSLIDE® MAGNETIC SLIDE CHIP AND PARTS CONVEYORS MOVE ABRASIVE FERROUS MATERIAL

Bunting MagSlide® Chip and Parts Conveyors are built to handle sharp, abrasive ferrous parts and scrap that can damage conventional belt conveyors. Instead of a moving belt, they have moving magnets that pull ferrous materials along from behind a stationary stainless steel slider bed. MagSlide Conveyors are ideal for use anywhere you need to transfer ferrous chips, turnings, and small parts from lathes, mills, or stamping presses – or from slitting, forming, or other metalworking operations. Designed to be economical to operate and easy to maintain, MagSlide Conveyors are made for trouble-free operation. The rugged twin-roller drive chains that hold and move the conveyor magnets travel in oil-impregnated Bunting SlideTrack™ channels that provide continuous lubrication. Friction and noise are minimized. To further extend chain life, optional built-in oil fittings permit manual or automatic supplemental



Permanently lubricated drive chains move permanently charged high-energy Ceramic or Rare Earth magnets inside the conveyor housing. These magnets, in turn, move ferrous materials along the conveyor's heavy-gauge stainless steel slider bed.

lubrication.

MagSlide Conveyors are CAD engineered and manufactured on advanced CNC punching, milling, and turning equipment for precision fit and long-term reliability. Models include horizontal, inclined, and angled units with both fixed and mobile bases, as well as low-profile conveyors. Except for the electric motor, all moving parts are totally enclosed. Optional watertight housings can be submerged.



- **High-energy Ceramic and Rare Earth magnets handle a wide range of shapes and weights.**
- **Precision manufacturing and rugged construction ensure long and reliable service.**
- **Oil-impregnated SlideTrack made from ultra-high-molecular-weight polyethylene provides continuous chain lubrication.**
- **MagSlide design minimizes maintenance and service requirements.**

Two surface styles are available.

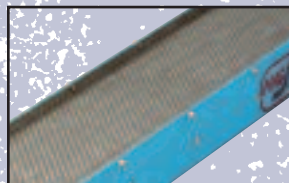

Optional rigidized (textured) stainless steel sliderbed is for oily slugs and scrap.

Available on low-profile models only.

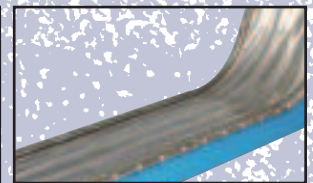

Standard Sliderbed can be upgraded to thicker material and impact plates are optional.

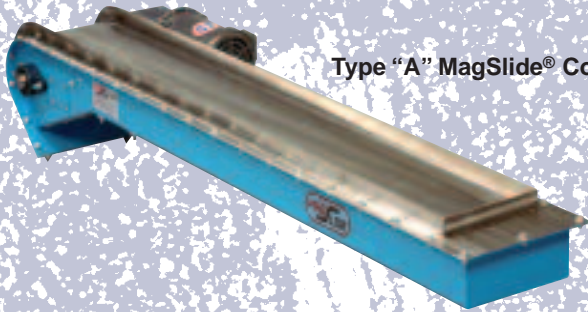

Type "A" MagSlide® Conveyor

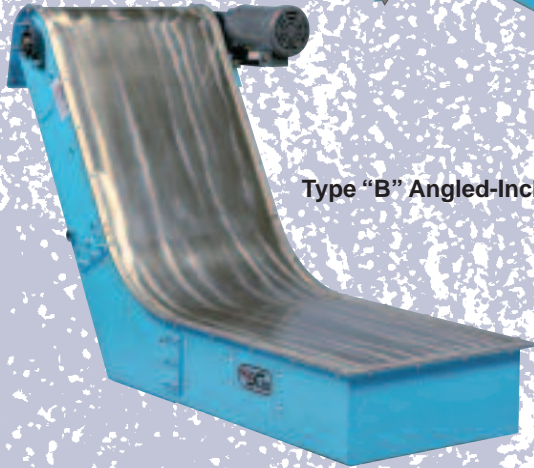

Type "B" Angled-Incline MagSlide®

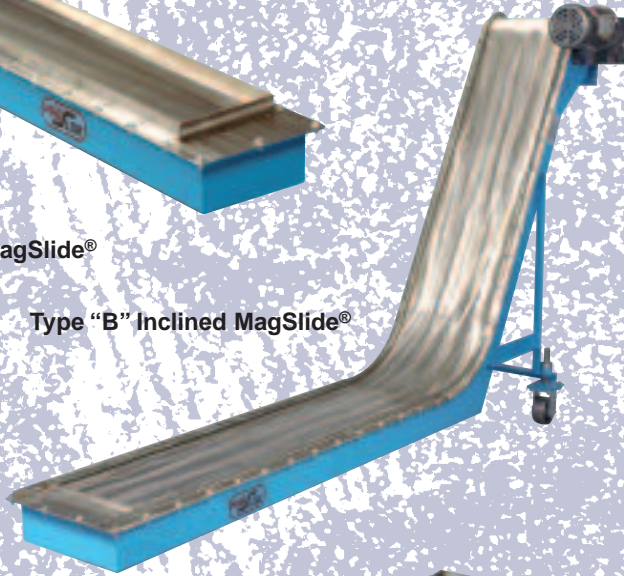

Type "B" Inclined MagSlide®

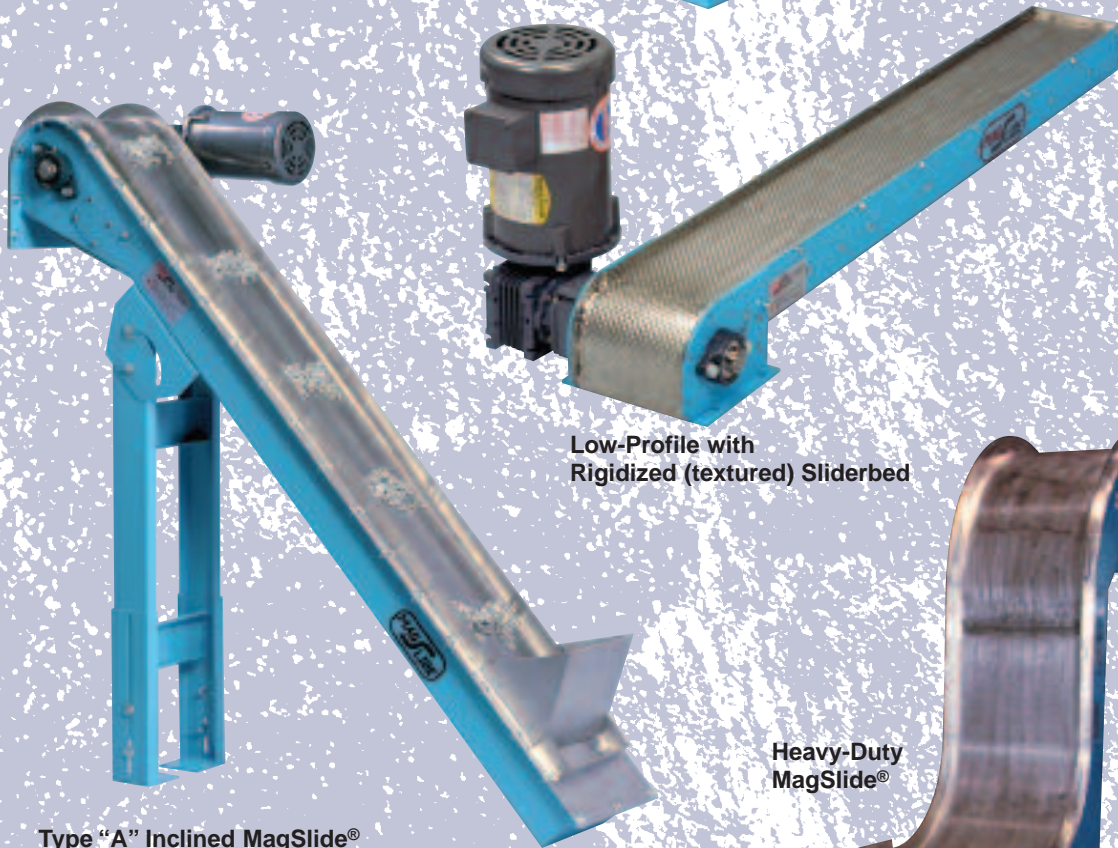

Low-Profile with Rigidized (textured) Sliderbed



Type "A" Inclined MagSlide®

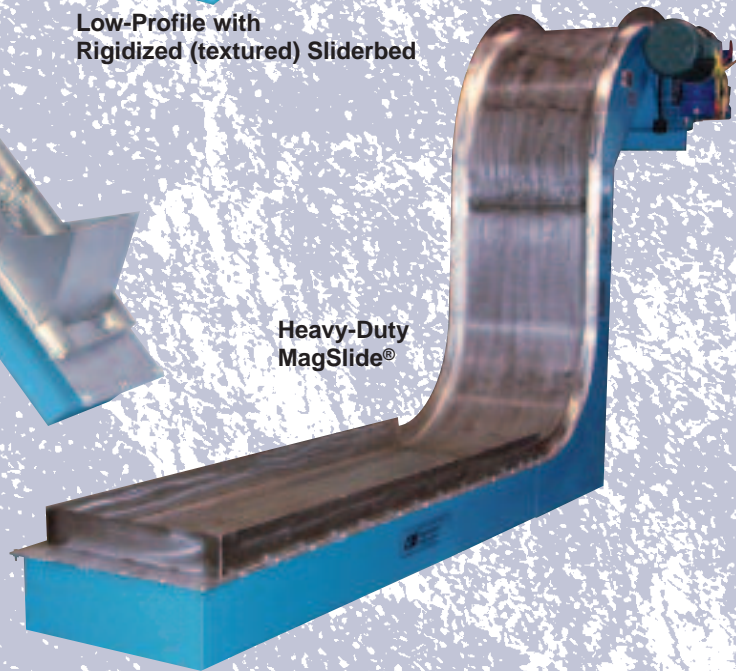

Heavy-Duty MagSlide®

MagSlide® Beltless Conveyors

BUNTING SHEET FANNERS

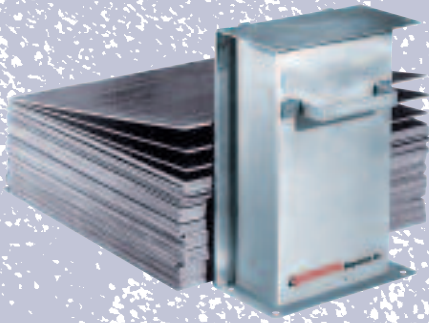

Stainless steel Sheet Fanners separate stacks of oily, jagged-edged sheets magnetically for faster, safer handling. Both

standard and pneumatic models are available in a variety of sizes and can be used in tandem to handle larger sheets. Permanent magnets provide a constant, powerful magnetic force that automatically “fans” sheets apart. Operators can safely handle one sheet at a time, eliminating the chance of jamming “doubles” into production equipment.

These rugged all-stainless-steel units stand up to rough daily usage next to presses, shears, and other machines. They come with carrying handles for moving from one workstation to another and with holes for permanent mounting, if desired. Units can be ganged to handle larger sheets.

Bunting magnetic Pneumatic Sheet Fanners add on/off control for faster sheet handling. Operation is controlled by a pneumatic rotary magnetic element that rotates the magnetic field. This brings the magnetic field into contact with the stacks of ferrous sheets and fans them apart. When released, the magnetic element is rotated into a safe position, effectively turning the magnetic force off.

“U.S. Patent No. 6,481,706”

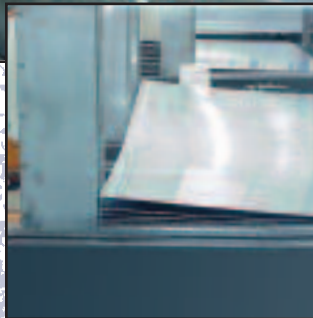
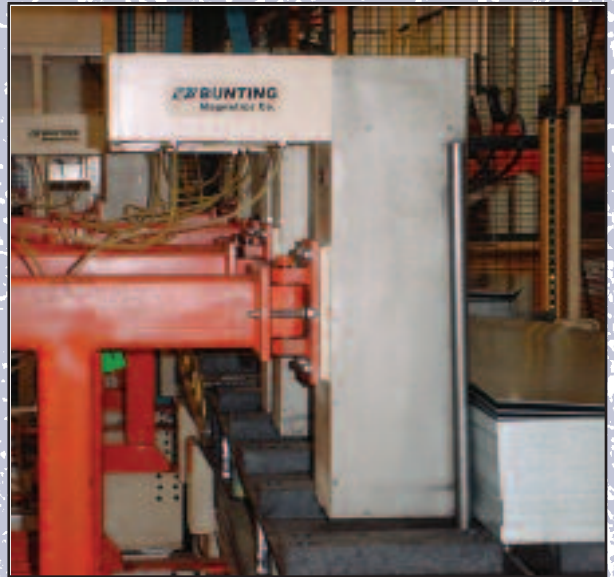
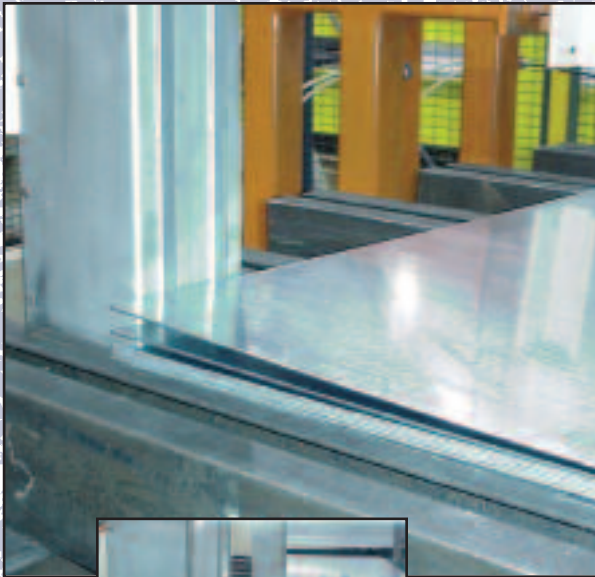

MAGNETIC LAWNCHAIR CONVEYORS ELIMINATE MANUAL HANDLING OF TOTE PANS

Bunting Magnetic Lawnchair Conveyors have been built specifically to automate removal of ferrous parts and scrap that drop through bolster plates and frame chutes of punch presses and other machinery. Their lawn-chair-like profile features a long, low horizontal extension that can be positioned under machinery to retrieve ferrous materials. Operators no longer have to bend and reach to remove heavy collection totes.

Our MLCs also eliminate the common problem of part and scrap overflow on the production line. They maintain positive control and movement of ferrous materials and feed into hoppers or containers.

Magnetic Lawnchair Conveyors are made in four standard sizes and two styles – plus custom models. Heavy-duty, lockable castors allow these conveyors to be moved from one machine to another. A skid-base model can be ordered to handle especially low infeed heights.



- **Standard portable model can serve multiple machines.**
- **Retrieve ferrous material from deep under presses and other machinery.**
- **Save downtime and labor costs.**
- **Select model, size, drive motor, belt options, and magnetic elements suited to your application.**
- **Single-Belt MLC handles parts and scrap 2 inches in diameter or larger.**
- **Double-Belt MLC is designed for removing smaller knockouts and scrap.**

CUSTOM CONVEYORS HANDLE UNIQUE APPLICATIONS

Custom Conveyors from Bunting Magnetics Co. give you highly specialized control of conveyed ferrous materials and enable you to reduce labor costs, minimize downtime, and improve throughput. Whether you are planning plant-wide automation or just streamlining a specific operation, we can design what you need, including all necessary switches, drives, electronic controls, and high-capacity options.

Just as with our stock units, permanent magnets in our custom conveyors are matched to your specific application to hold ferrous materials securely against conveyor belts or slider beds. A wide range of parts

- Increase plant safety, efficiency, and productivity.
- Control the movement of ferrous and partially ferrous material.
- Feed machinery and remove processed parts.
- Orient and sequence work pieces.
- Elevate material up, over, and around machinery.
- Accumulate and stack parts for processing, storage, or shipment.
- Save space, time, and expense handling ferrous material.

and scrap can be moved up inclines as steep as 90 degrees, providing positive control of spacing, orientation, direction, and release points.

Our engineers use the latest computer-aided design technology and CNC production techniques to “custom fit” conveyors and integrate them into new or existing lines. They can be configured to transport, order, and release a wide variety of ferrous materials in many shapes and sizes.

Look over the photographs on these pages to see how we can handle unique production problems with custom conveying solutions.



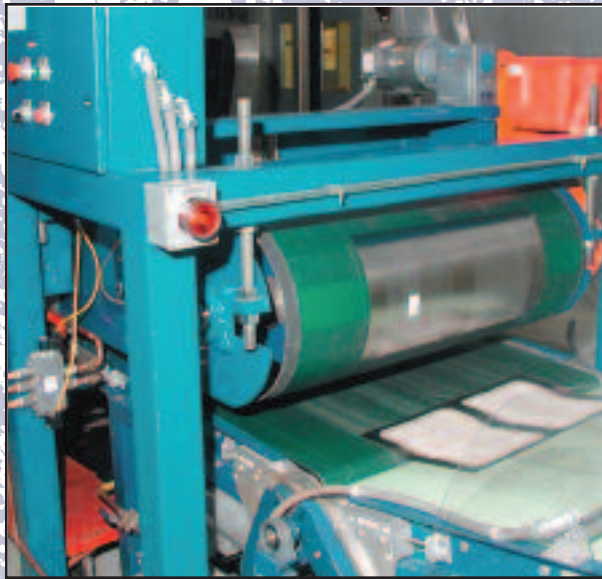
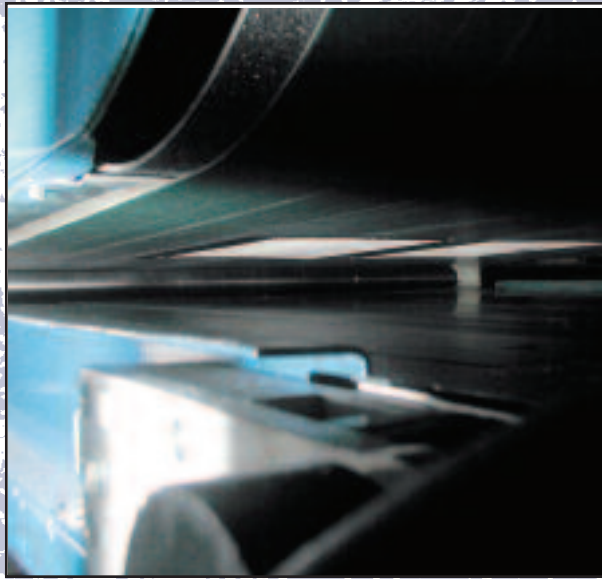

Custom Magnetic Conveying Systems

POWERTRAC® MODULAR ALUMINUM FRAME CONVEYORS

Save Time, Labor, and Maintenance Costs

PowerTrac Conveyors offer economical solutions to a host of challenging conveying applications. They come in low- and medium-profile models that offer made-to-order fit, a wide choice of options, and easy maintenance. V-guide tracks keep belts centered even when heavily side-loaded. Sealed self-aligning bearings, positive drive, and exceptionally easy belt changes further reduce maintenance.

Made-To-Order Fit at a Pre-Engineered Price



You can get the exact size and configuration you want at an economical pre-engineered price. Select from a wide range of the lengths, widths, drive options, belts, and accessories to custom fit PowerTrac Conveyors to your plant layout. They are engineered to handle most light and medium-duty belt-type conveyor applications and can be equipped with optional magnet assemblies for use with ferrous materials. Whether yours is a new or retrofit installation, chances are PowerTrac can meet your needs.

PowerTrac aluminum frames feature full-length T-slots that make it easy to mount motion controls, stops, and sensors to streamline your operation. Multiple drive options provide a wide range of belt speeds for various product-load requirements. Our sales representatives and engineers will be glad to help you select an individual conveyor or design a complete PowerTrac system.



- Extruded aluminum frames feature full-length T-slots for mounting controls, brackets, and accessories.
- Rack and pinion belt tensioning speeds and simplifies belt changes.
- V-guide track in sliderbed keeps guided belts centered.
- Standard belt-tracking adjustments accommodate a wide assortment of special purpose belts and compensate for unevenly stretched belts.
- Knurled stainless steel drive rollers provide positive, steady drive traction even under heavy loads.
- Sealed self-aligning ball bearings maintain tight tolerances.
- Robust box-like construction resists twisting even with unbalanced loading.
- Rugged die-cast aluminum end plates resist wear.
- Stainless steel slider bed offers low resistance for economical operation.
- Optional side belt wipers keep dirt and debris from getting under flat belts.
- Optional nose bar with .125" radius facilitates close side- and end-load part transfers.

LOW-PROFILE POWERTRAC® CONVEYORS

Increase Material Handling Efficiency Where Space is Limited

Bunting Low-Profile PowerTrac Conveyors transform tedious manual processes into an automated operation. These sturdy, dependable aluminum-frame conveyors are ideal for use in parts handling and automated assembly line applications and can fit in limited spaces. Gang drive assemblies can be configured to power a series of PowerTrac conveyors with a single drive



motor.

- Compact frame needs less than 2" of vertical clearance.
- Units can be equipped with magnet assemblies to hold ferrous materials on the belt during transport.
- Standard models come 1.875 inches high, 2" to 24" wide, and up to 20' in length.
- Custom sizes are available on special order.
- End-drive models have left or right and top or bottom drive mounts.
- Center drive models allow for greater belt pulling power and reversing applications.

MEDIUM-FRAME POWERTRAC® CONVEYORS

Handle Bigger Parts, Loading Bigger Jobs with Ease

Economical Bunting Medium-Frame PowerTrac Conveyors are tough enough to handle a broad range of applications. Their trim 3.875" frames can fit where space is limited. But they have the strength and versatility to tackle heavier parts and workflow.

Like their low-profile counterparts, Medium-Frame PowerTrac Conveyors offer the performance, features, and rugged construction to save you time and money during years of trouble-free operation.

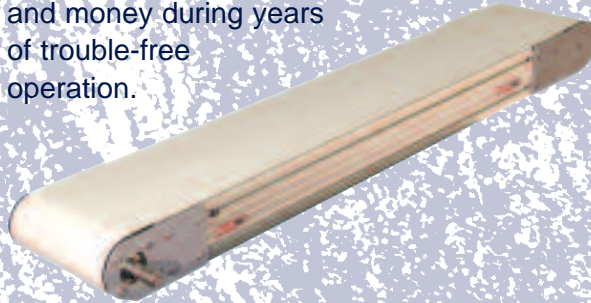

- Optional magnet assemblies can be frame mounted to hold ferrous materials on the belt while being conveyed on inclines or even upside down.
- Standard models measure 3.875 inches high and can be ordered 4" to 36" wide and up to 100' in length.
- End-drive models have left or right and top or bottom drive mounts.
- Center drive models allow for greater belt pulling power and reversing applications.

BUNTING “MOVE-IT” SYSTEMS™ FOR PERFORMANCE AND VALUE

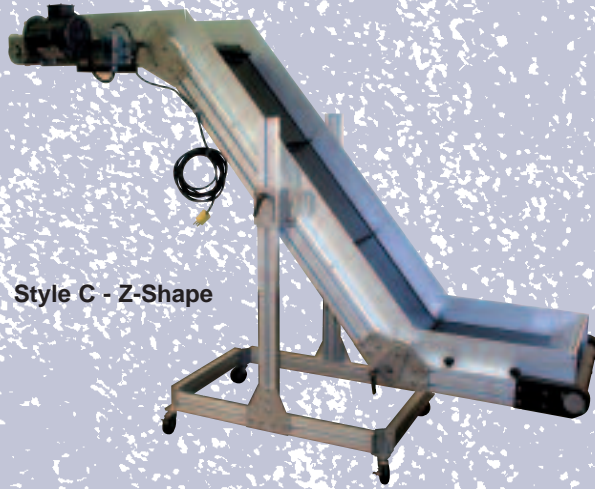

Style C - Z-Shape



Style D - Noseover



Style E - Elevator



Style A - Straight Frame



Style B - Gooseneck

“MOVE-IT” Conveyors are built to order but priced like stock. They come in most common conveyor sizes and can be custom ordered in a wide range of lengths and widths of 12 to 36 inches in 6-inch increments to fit your application. All models feature sturdy aluminum construction, heavy-duty bearings, and a simple, straightforward design that is both reliable and

easy to maintain. Electrical components and variable-speed drive motors are available to match the power needs of each installation. Durable cleated belts and easy angle adjustments allow you to move parts and scrap up and down inclines as well as along horizontal runs for maximum layout flexibility.

STRAIGHT FRAME MODELS

Straight Frame “Move-It”™ Conveyors are suited to horizontal or incline conveying to grinders, totes, or to the next workstation. They also serve for under-press injection molding applications, box transfer, and scrap removal.



An optional chute collects parts or scrap for transport. Standard belts can be used for 10-degree inclines. High-friction or grip-top belts work for slopes up to 30 degrees. For higher angles, cleated belts keep materials moving.

GOOSENECK MODELS

Gooseneck Conveyors receive parts that discharge underneath machinery and convey them to totes or other conveyors.



The standard belts are PVC with 1.5-inch cleats and polypropylene belts with 2-inch cleats, both on 16-inch centers. The incline on these conveyors ranges from 25° to 50°. Standard infeed flaps contain product.

Z-SHAPE MODELS

“Move-It” Z-Shape Conveyors combine the capabilities of horizontal and incline conveyors in a single unit. They can collect parts from underneath machinery and convey them to totes or other conveyors. The standard fabric belt is PVC with 1.5-inch high cleats on 16-inch centers. Standard polypropylene belts have 2-inch cleats on 16-inch centers. Incline angle is adjustable from 25° to 50°. Infeed flaps to contain product are standard.



NOSEOVER MODELS

Noseover Conveyors typically receive parts from an overhead robot and lower them to an operator or a tote, but they are also used to elevate parts to totes or grinders. These conveyors may be provided with high friction or cleated belts, depending on the part and the incline. The incline angle is

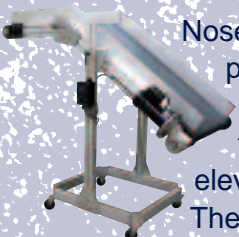

adjustable from 15° to 50°.

ELEVATOR MODELS

Elevator Conveyors receive small parts from production operations and convey them into totes or feeder bowls. These sturdy conveyors offer incline adjustment from 15° to 60°. The standard fabric belt is PVC with 1-inch high cleats on 6-inch centers. Higher cleats are recommended for steep inclines. Infeed hoppers and discharge chutes

are standard equipment. The **“Move-It”™ System instant portability** for use at multiple workstations.

- Drives come in constant speed, variable speed, and robot controlled models.
- Five standard models fit most applications.
- Belts come in five standard widths: 12, 18, 24, 30, and 36 inches.
- Patent-pending Belt Angle Adjustment lets operators set incline over a wide range.
- Durable industrial-grade PVC V-Belts stay centered, resist damage, and operate at temperatures up to 160° F.
- Flat belting is available with smooth or high friction surfaces.
- Calibrated speed dial on variable-speed drives simplifies adjusting belt speed.
- Belt tension adjusts easily with an ordinary wrench.
- Elevator models have a built-in chute that collects parts or scrap for transport and cleated belts for even product flow.
- Adjustable discharge chute aids in conveying small parts in bulk.
- Extruded aluminum frames are lightweight yet shaped and braced for exceptional rigidity.
- Strong heavy-duty locking castors for portability.

GRINDER/SHREDDER FEED CONVEYORS WITH OPTIONAL METAL DETECTORS FOR PROTECTION AGAINST TRAMP METAL

Grinder/Shredder Feed Conveyors let you detect both ferrous and nonferrous metal contaminants in conveyed material before they damage equipment or compromise product. It combines a rugged Bunting Conveyor with optional Bunting magnetic metal separators or metal detectors to spot and remove contaminants. Bunting Metal Detectors sense all conductive metals and feature self-diagnostics for easy adjustment and reliable operation. All available detectors have triple-coil, high-frequency metal detection systems with Product-Effect Compensation and EMI/RFI filters.

- Use with grinders or shredders or to inspect finished parts.
- Install an optional Bunting Magnetic Metal Separator to find tramp iron in virgin and recycled plastics, rubber, and other conveyed materials.
- Equip the conveyor with an optional Bunting Metal Detector to sense and segregate *all* conductive metals.
- Grinder/Shredder Feed Conveyors with tunnel style metal detectors feature an LCD touch screen interface for entering settings.
- Choose from a long list of customizing options.



In these photographs, side guards have been removed from the conveyors to show the metal detector's design.

BUNTING MAGNETICS ENGINEERS COMPLETE SYSTEMS FOR GRINDER AND SHREDDER APPLICATIONS. CALL US FOR ALL OF YOUR DISCHARGE CONVEYORS, TRANSFER CONVEYORS, PARTS HANDLING CONVEYORS, MAGNETIC CROSS-BELT SEPARATION, AND METAL DETECTION NEEDS.

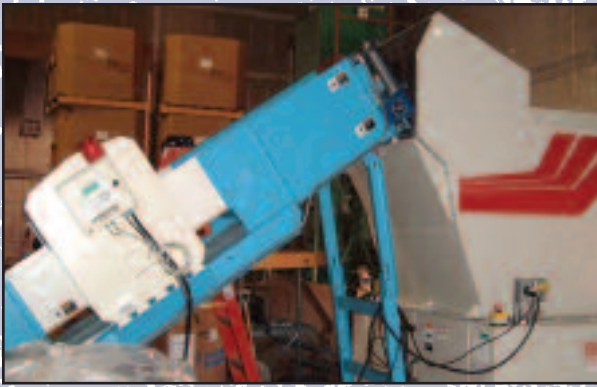

Grinder/Shredder Feeder Conveyors



Plastics Processing

Bunting has established leadership in plastics separation by meeting customer needs with Magnetic Metal Separators and electronic Metal Detectors designed for a full range of plastics processing applications.

Request Catalog #4500

Metal Separation

Protect product purity and equipment with the most complete line of Magnetic Separation Equipment. Bunting Magnetic Separators achieve exceptional removal of ferrous tramp with models for all applications.

Request Catalog #4000

Metal Detectors

Bunting Detectors offer exceptional sensitivity, speed, and reliability. Our electronic Metal Detectors reject both ferrous and nonferrous metal contaminants from gravity, pneumatic, and liquid conveying systems.

Request Catalog #4200

Printing Products

Bunting makes Magnetic Printing Cylinders and Bases guaranteed to OEM specs. Our precision cylinders include dry offset, flexo, corrugated, die-cutting, embossing, and hot stamping models.

Request Catalog #5000

Magnetic Materials & Assemblies

Rare Earth, Ceramic, and Alnico magnets and Holding Assemblies in hundreds of shapes and sizes are in stock and ready to ship from our Chicago facility. Also – Magnetic Lifters, Tools, and Sheet Fanners.

Request Catalog #3000

PUT BUNTING TO WORK IN YOUR PLANT

Bunting Magnetics Co. gives you a dependable source of supply to meet your material handling needs. Bunting also offers you other lines of magnet-based equipment. Bunting products reduce labor and maintenance costs, improve product quality and safety, and protect machinery from damage, downtime, and costly repairs in many industries. Count on us and call on us whenever you need information, expert consultation, and the best in magnet-based products and service.

For technical assistance or to order, call

(800) 835-2526

Outside U.S. and Canada 1-316-284-2020

or visit our web site

www.buntingmagnetics.com

BUNTING Magnetics Co.

500 S. Spencer Avenue • P.O. Box 468 • Newton, KS 67114-0468 • USA

1-316-284-2020 • Fax 1-316-283-4975

E-mail: bmc@buntingmagnetics.com • www.buntingmagnetics.com

Stocking Branch

1150 Howard Street • Elk Grove Village, IL 60007 • USA • 1-847-593-2060 • Fax 1-847-593-2045

Sales Offices

Canada – Toronto, Ontario **Australia** – Boronia, Victoria