

BARREL HARDWARE CLAMPS

Zinc Plated & Stainless Steel Barrels



Performance Meets Safety

Clampco offers Barrel Hardware Clamps as yet another fastening solution. When space constraints prohibit the use of standard T-Bolt Band Clamps, Barrel Hardware Clamps offer an attractive, low-profile design. With excellent product performance and attractive appearance, Barrel Hardware Clamps are popular components on appearance-driven products such as motorcycle exhaust systems and high-performance race cars. All stainless steel versions can be electro-polished for improved cosmetics.



Because of their design, Barrel Hardware Clamps ease certain installations. For example, as a Barrel Hardware Clamp is tightened, the end of the socket head cap screw moves away, rather than towards, the operator. This feature improves safety by minimizing parts that protrude after installation, and deep socket installation tools are not required.

Clampco Barrel Hardware Clamps are available in diameters as small as 1.50 in., perfect for tight, hard-to-access spaces. Standard materials for the clamps include 300 series stainless steel bands, zinc plated or stainless steel barrel trunnions and nuts, and stainless steel socket head cap screws.

CLAMPSCO



Custom Order

Clampco can also make custom Barrel Hardware Clamps. Some of our custom designs have included metric hardware, heavy-duty hardware, socket head cap screws, hex head bolts, different bandwidths, different band and hardware materials, and even quick-release styles. This picture shows a clamp with a barrel nut, regular stamped trunion, and a socket head cap screw.

We Customize. Call Today.

CUSTOM



SPECIFICATIONS

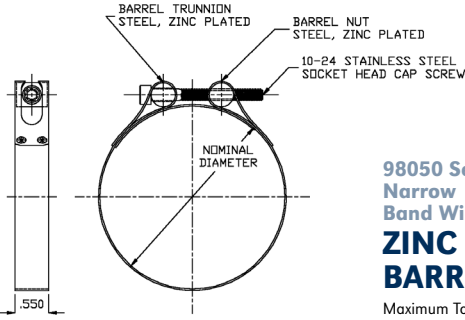

98050 Series Narrow Band Width = 0.55 in. ZINC PLATED BARRELS

Maximum Torque 30 in.-lbs.

ENGLISH (inches)

PART NUMBER	NOMINAL DIAMETER	MINIMUM DIAMETER	MAXIMUM DIAMETER
98050-0150	1.50	1.36	1.55
98050-0175	1.75	1.61	1.80
98050-0188	1.88	1.74	1.93
98050-0200	2.00	1.86	2.05
98050-0212	2.12	1.98	2.17
98050-0225	2.25	2.11	2.30
98050-0238	2.38	2.24	2.43
98050-0250	2.50	2.36	2.55
98050-0256	2.56	2.42	2.61
98050-0262	2.62	2.48	2.67
98050-0275	2.75	2.61	2.80
98050-0288	2.88	2.74	2.93
98050-0300	3.00	2.86	3.05
98050-0312	3.12	2.98	3.17
98050-0325	3.25	3.11	3.30
98050-0350	3.50	3.36	3.55
98050-0400	4.00	3.86	4.05
98050-0425	4.25	4.11	4.30
98050-0450	4.50	4.36	4.55
98050-0500	5.00	4.86	5.05
98050-0550	5.50	5.36	5.55
98050-0600	6.00	5.86	6.05
98050-0650	6.50	6.36	6.55
98050-0700	7.00	6.86	7.05
98050-0750	7.50	7.36	7.55
98050-0766	7.66	7.52	7.71
98050-0800	8.00	7.86	8.05
98050-0850	8.50	8.36	8.55

METRIC (millimeters)

NOMINAL DIAMETER	MINIMUM DIAMETER	MAXIMUM DIAMETER
38	35	39
45	41	46
48	44	49
51	47	52
54	50	55
57	54	58
60	57	62
63	60	65
65	61	66
67	63	68
69	66	71
73	70	74
76	73	77
79	76	81
82	79	84
88	85	90
101	98	103
107	104	109
114	111	116
127	123	128
139	136	141
152	149	154
165	162	166
178	174	179
191	187	192
194	191	196
203	200	204
216	212	217

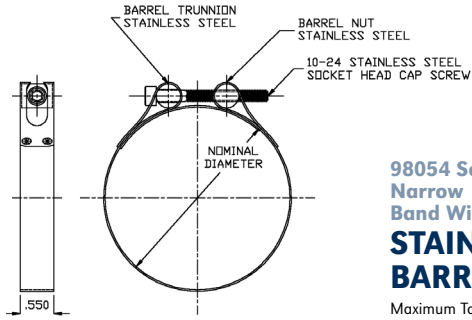

98054 Series Narrow Band Width = 0.55 in. STAINLESS STEEL BARRELS

Maximum Torque 30 in.-lbs.

ENGLISH (inches)

PART NUMBER	NOMINAL DIAMETER	MINIMUM DIAMETER	MAXIMUM DIAMETER
98054-0150	1.50	1.36	1.55
98054-0175	1.75	1.61	1.80
98054-0188	1.88	1.74	1.93
98054-0200	2.00	1.86	2.05
98054-0212	2.12	1.98	2.17
98054-0225	2.25	2.11	2.30
98054-0238	2.38	2.24	2.43
98054-0250	2.50	2.36	2.55
98054-0256	2.56	2.42	2.61
98054-0262	2.62	2.48	2.67
98054-0275	2.75	2.61	2.80
98054-0288	2.88	2.74	2.93
98054-0300	3.00	2.86	3.05
98054-0312	3.12	2.98	3.17
98054-0325	3.25	3.11	3.30
98054-0350	3.50	3.36	3.55
98054-0400	4.00	3.86	4.05
98054-0425	4.25	4.11	4.30
98054-0450	4.50	4.36	4.55
98054-0500	5.00	4.86	5.05
98054-0550	5.50	5.36	5.55
98054-0600	6.00	5.86	6.05
98054-0650	6.50	6.36	6.55
98054-0700	7.00	6.86	7.05
98054-0750	7.50	7.36	7.55
98054-0766	7.66	7.52	7.71
98054-0800	8.00	7.86	8.05
98054-0850	8.50	8.36	8.55

METRIC (millimeters)

NOMINAL DIAMETER	MINIMUM DIAMETER	MAXIMUM DIAMETER
38	35	39
45	41	46
48	44	49
51	47	52
54	50	55
57	54	58
60	57	62
63	60	65
65	61	66
67	63	68
69	66	71
73	70	74
76	73	77
79	76	81
82	79	84
88	85	90
101	98	103
107	104	109
114	111	116
127	123	128
139	136	141
152	149	154
165	162	166
178	174	179
191	187	192
194	191	196
203	200	204
216	212	217

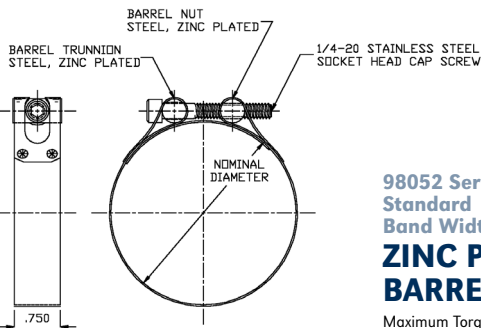

98052 Series Standard Band Width = 0.75 in. ZINC PLATED BARRELS

Maximum Torque 75 in.-lbs.

ENGLISH (inches)

PART NUMBER	NOMINAL DIAMETER	MINIMUM DIAMETER	MAXIMUM DIAMETER
98052-0150	1.50	1.36	1.64
98052-0175	1.75	1.61	1.89
98052-0188	1.88	1.74	2.02
98052-0200	2.00	1.86	2.14
98052-0212	2.12	1.98	2.26
98052-0225	2.25	2.11	2.39
98052-0238	2.38	2.24	2.52
98052-0250	2.50	2.36	2.64
98052-0256	2.56	2.42	2.70
98052-0262	2.62	2.48	2.76
98052-0275	2.75	2.61	2.89
98052-0288	2.88	2.74	3.02
98052-0300	3.00	2.86	3.14
98052-0312	3.12	2.98	3.26
98052-0325	3.25	3.11	3.39
98052-0350	3.50	3.36	3.64
98052-0400	4.00	3.86	4.14
98052-0425	4.25	4.11	4.39
98052-0450	4.50	4.36	4.64
98052-0500	5.00	4.86	5.14
98052-0550	5.50	5.36	5.64
98052-0600	6.00	5.86	6.14
98052-0650	6.50	6.36	6.64
98052-0700	7.00	6.86	7.14
98052-0750	7.50	7.36	7.64
98052-0766	7.66	7.52	7.80
98052-0800	8.00	7.86	8.14
98052-0850	8.50	8.36	8.64

METRIC (millimeters)

NOMINAL DIAMETER	MINIMUM DIAMETER	MAXIMUM DIAMETER
38	35	42
45	41	48
48	44	51
51	47	54
54	50	57
57	54	61
60	57	64
63	60	67
65	61	69
67	63	70
69	66	73
73	70	77
76	73	80
79	76	83
82	79	86
88	85	92
101	98	105
107	104	112
114	110	118
127	123	131
139	136	143
152	149	156
165	162	169
178	174	181
191	187	194
194	191	198
203	200	207
216	212	219

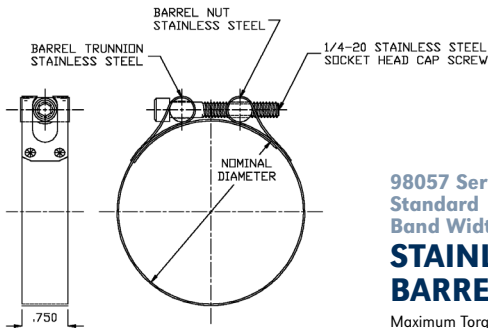

98057 Series Standard Band Width = 0.75 in. STAINLESS STEEL BARRELS

Maximum Torque 75 in.-lbs.

ENGLISH (inches)

PART NUMBER	NOMINAL DIAMETER	MINIMUM DIAMETER	MAXIMUM DIAMETER
98057-0150	1.50	1.36	1.64
98057-0175	1.75	1.61	1.89
98057-0188	1.88	1.74	2.02
98057-0200	2.00	1.86	2.14
98057-0212	2.12	1.98	2.26
98057-0225	2.25	2.11	2.39
98057-0238	2.38	2.24	2.52
98057-0250	2.50	2.36	2.64
98057-0256	2.56	2.42	2.70
98057-0262	2.62	2.48	2.76
98057-0275	2.75	2.61	2.89
98057-0288	2.88	2.74	3.02
98057-0300	3.00	2.86	3.14
98057-0312	3.12	2.98	3.26
98057-0325	3.25	3.11	3.39
98057-0350	3.50	3.36	3.64
98057-0400	4.00	3.86	4.14
98057-0425	4.25	4.11	4.39
98057-0450	4.50	4.36	4.64
98057-0500	5.00	4.86	5.14
98057-0550	5.50	5.36	5.64
98057-0600	6.00	5.86	6.14
98057-0650	6.50	6.36	6.64
98057-0700	7.00	6.86	7.14
98057-0750	7.50	7.36	7.64
98057-0766	7.66	7.52	7.80
98057-0800	8.00	7.86	8.14
98057-0850	8.50	8.36	8.64

METRIC (millimeters)

NOMINAL DIAMETER	MINIMUM DIAMETER	MAXIMUM DIAMETER
38	35	42
45	41	48
48	44	51
51	47	54
54	50	57
57	54	61
60	57	64
63	60	67
65	61	69
67	63	70
69	66	73
73	70	77
76	73	80
79	76	83
82	79	86
88	85	92
101	98	105
107	104	112
114	110	118
127	123	131
139	136	143
152	149	156
165	162	169
178	174	181
191	187	194
194	191	198
203	200	207
216	212	219