

NC MAGNETIC FLOAT SWITCHES FOR LIQUIDS

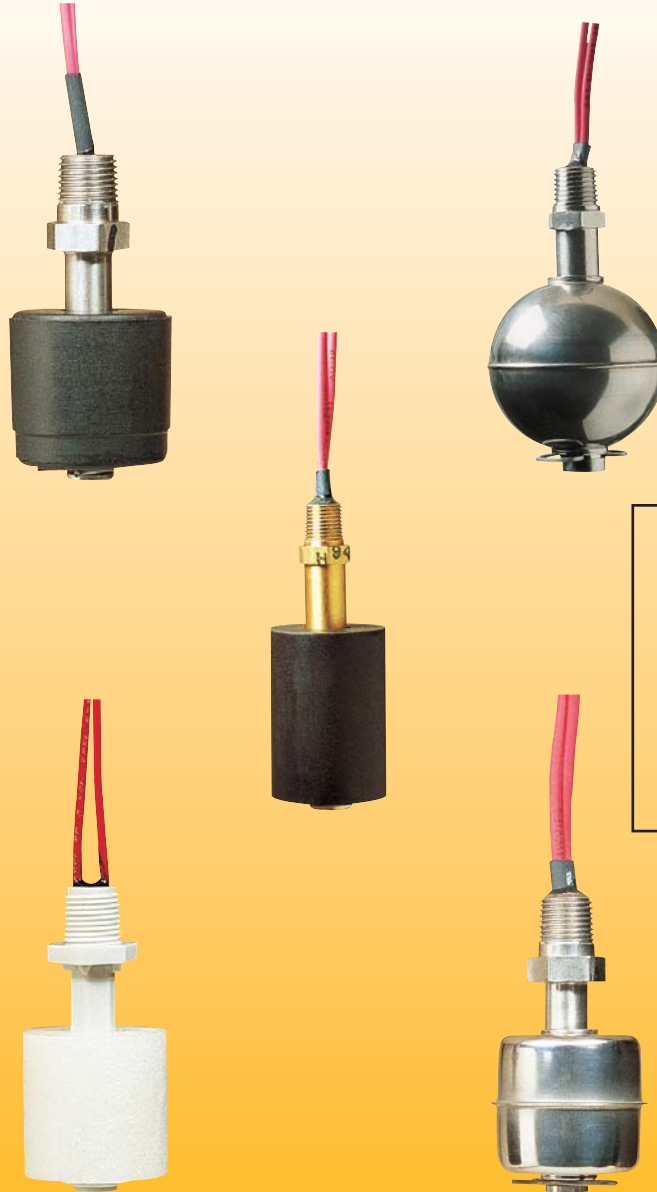

Flow
Pressure
Level
Temperature
measurement
monitoring
control

N1



- Available Materials: Brass, Stainless Steel, Buna-N, Polypropylene and PVC
- Maximum Pressure: 400 PSIG
- Maximum Temperature: 300°F
- Singlepoint and Multipoint Designs
- Field Changeable Switch Logic



USA

KOBOLD Instruments Inc.
1801 Parkway View Drive
USA-Pittsburgh, PA 15205
☎ +1 412-788-2830
Fax +1 412-788-4890
E-mail: info@koboldusa.com



CANADA

KOBOLD Instruments Canada Inc.
9A Aviation
Pointe-Claire, QC H9R 4Z2
☎ +1 514-428-8090
Fax +1 514-428-8899
E-mail: kobold@kobold.ca

Visit KOBOLD Online at
www.kobold.com

Model:
NC

HIGH QUALITY LEVEL SWITCHES FOR EVERY APPLICATION

Versatile Design

KOBOLD level switch products are designed to meet a wide range of application requirements by addressing such design considerations as:

- Pressure and Temperature
- Mounting Orientation
- Termination
- Media Characteristics such as Density, Viscosity and Corrosivity
- Materials of Construction
- Switch Load

Operation

All KOBOLD level switches use a hermetically sealed reed contact actuated by a magnet in the float. As the float rises and falls, the magnetic field causes the switch inside the stem to open or close.

KOBOLD level switches can be mounted in the tank top or bottom, or can be adapted for side mounting. Switches will operate normally with up to a 30 degree tilt from vertical.

All single point switches are field selectable for normally open (N/O) or normally closed (N/C) switch operation by simply removing the retaining ring and flipping the float.

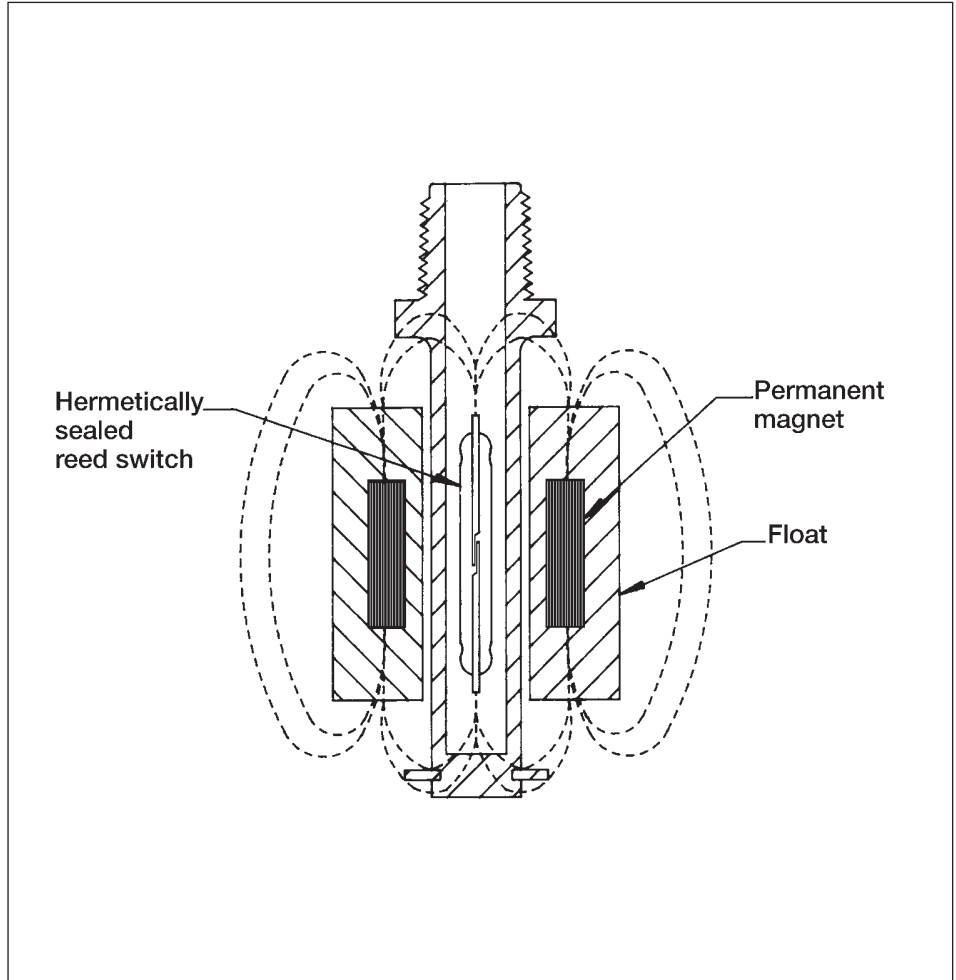

Design Flexibility

Some KOBOLD level switches can be provided to detect the interface between two dissimilar liquids such as water and oil.

KOBOLD level switches can be provided with other mounting styles such as flanges, bent stem, different NPT, straight threads, and metric size mounting plugs.

KOBOLD level switches can be made intrinsically safe for hazardous applications by the use of Zener barriers such as the EX-3001. Contact protection relays like the RL-6101 should always be considered to protect switches from overload.

Electrical Data

Switch Ratings – Resistive Loads				
Contact Rating	Switch Type	Maximum Voltage	Maximum AC	Current DC
20 VA	SPST	240 VAC/50VDC	0.7A	0.4A
100 VA	SPST	240 VAC/50VDC	3.0A	0.4A
20 VA	SPDT	240 VAC/50 VDC	0.7A	0.4A

NOTE: Above ratings are for resistive loads only.

NCP SMALL POLYPROPYLENE SWITCHES

Top Mount NCP-2554

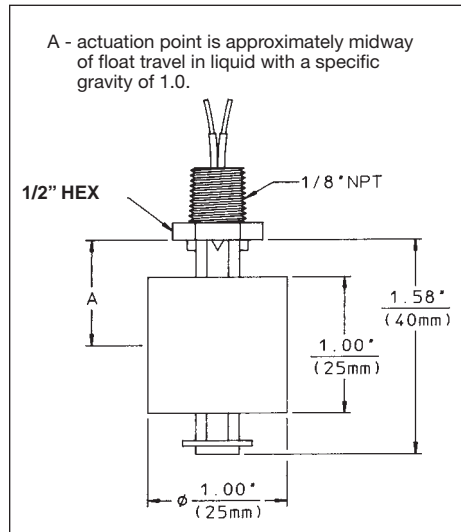
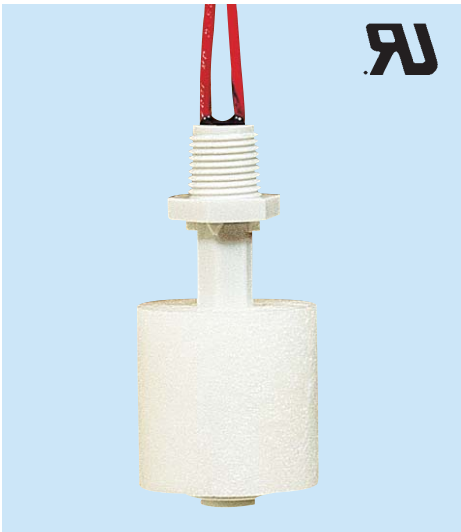

Top Mount Model NCP-2554

Features

- Small, compact size with small displacement
- Highly reliable, yet inexpensive
- Seamless cellular construction
- Excellent chemical resistance
- Available in FDA approved polypropylene

Specifications

Max. Pressure: 100 PSIG
Temperature Range
 Operating: - 40 °F to 225 °F
Fittings: 1/8" NPT
Leads: 22 AWG×24"
Liquid Specific Gravity
 Minimum: 0.81

Side Mount NCP-5094

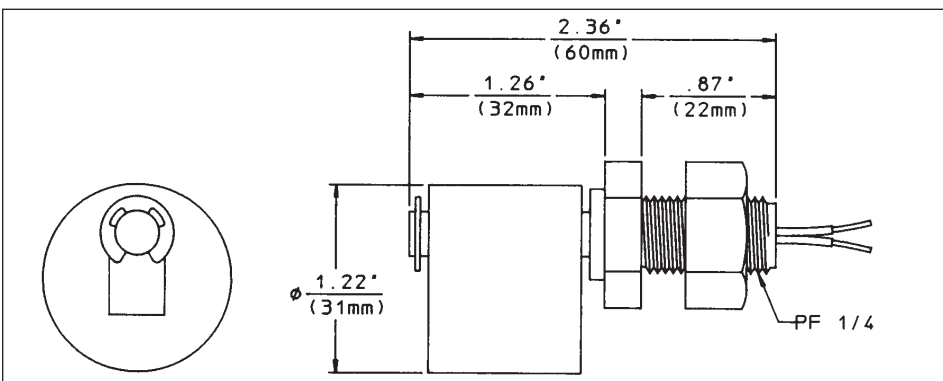
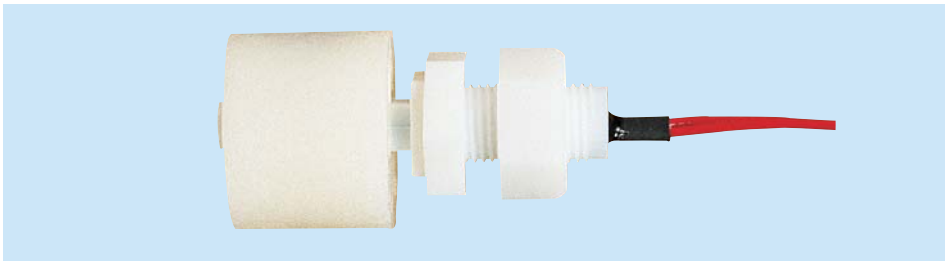

Side Mount Model NCP-5094

Features

- Side mount design fits small vessels
- Minimal float travel and displacement
- Highly chemical resistant

Specifications

Max. Pressure: 40 PSIG
Temperature Range: - 40 °F to 176 °F
Fittings: PF 1/4" (1/2"×20)
Leads: 22 AWG×24"
Liquid Specific Gravity
 Minimum: 0.81

NCP Ordering Information

Type	Part No.	Stem/Float Material	Switch
Top Mount	NCP-2554	Polypro/Polypro	20 VA, SPST
Side Mount	NCP-5094	Polypro/Polypro	20 VA, SPST

N1

NCB SMALL BUNA-N SWITCHES

General Purpose NCB-1054 & NCB-1064

General Purpose NCB-1054 & NCB-1064

Features

- Small, compact size, 1" dia. float
- Precise repeatability
- Reliable, long-life performance
- Highly resistant to shock and vibration
- Buna-N float
- Stems available in 316 SS or Brass

Specifications

Max. Pressure: 150 PSIG
Operating Temperature Range
 In Oil: - 40 °F to 230 °F
 In Water: - 40 °F to 180 °F
Fittings: 1/8" NPT
Leads: 22 AWG×24"
Liquid Specific Gravity
 Minimum: 0.55

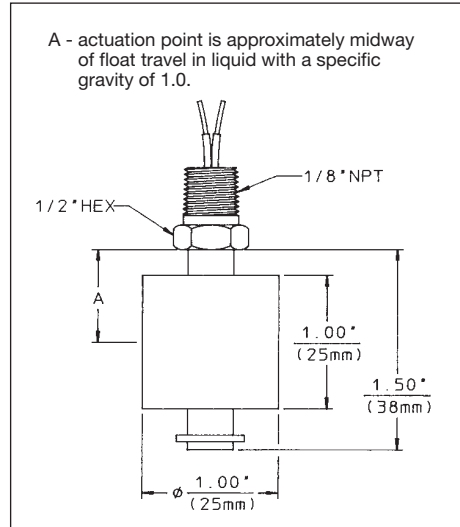

Side Mount NCB-5084

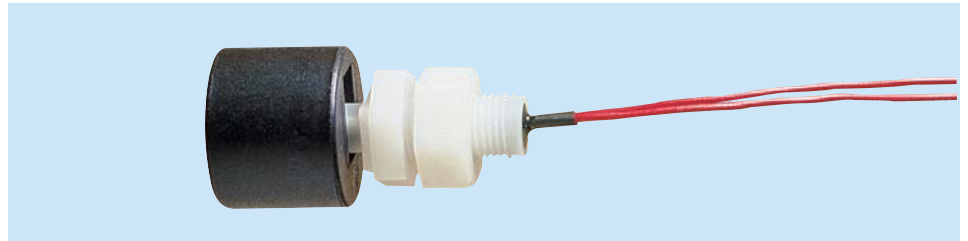

Side Mount Model NCB-5084

Features

- Side mount design fits small vessels
- Minimal float travel and displacement
- Highly chemical resistant
- Buna-N float with Polyacetal stem

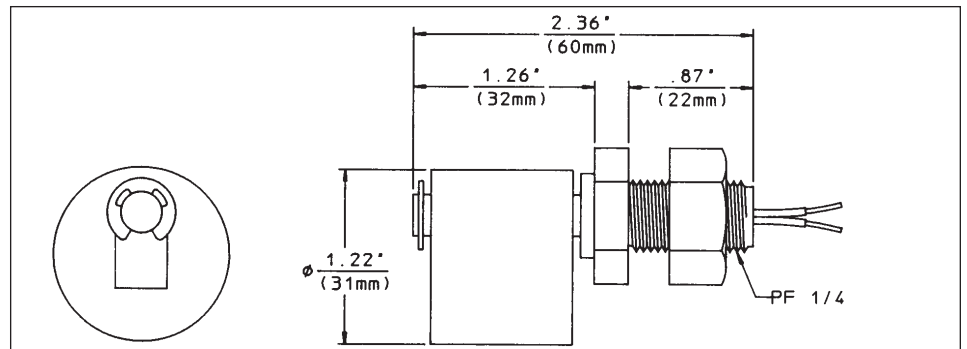

Specifications

Max. Pressure: 70 PSIG
Temperature Range: - 40 °F to 176 °F
Fittings: PF 1/4" (1/2"×20)
Leads: 22 AWG×24"
Liquid Specific Gravity
 Minimum: 0.60

NCB Ordering Information

Type	Part No.	Stem/Float Material	Switch
Top Mount	NCB-1054	316 SS/Buna-N	20 VA, SPST
Top Mount	NCB-1064	Brass/Buna-N	20 VA, SPST
Side Mount	NCB-5084	Polyacetal/Buna-N	20 VA, SPST

NCB GENERAL PURPOSE BUNA-N SWITCHES

Intermediate Size NCB-1000

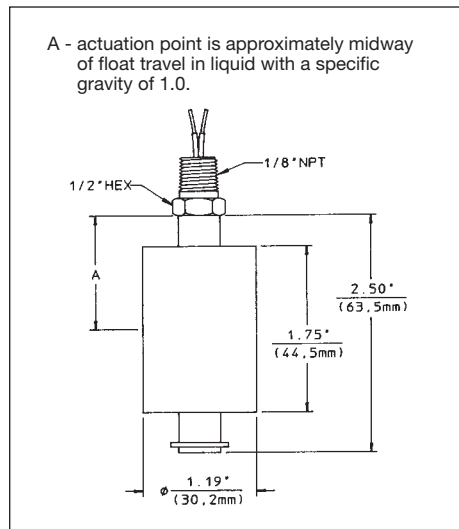

NCB-1000 Intermediate Size

Features

- Highly reliable, yet inexpensive
- Compact, narrow displacement
- Stem available in 316 SS or Brass
- Long operating life

Specifications

Max. Pressure: 150 PSIG
Operating Temperature Range
In Oil: - 40 °F to 230 °F
In Water: - 40 °F to 180 °F
Fittings: 1/8 NPT
Leads: 18 AWG×24
Liquid Specific Gravity
Minimum: 0.55

Large Size NCB-5000

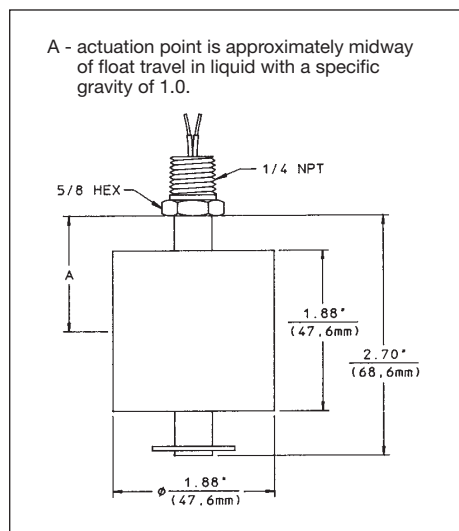

NCB-5000 Large Size

Features

- Large float provides maximum displacement in high viscosity fluids
- Rugged design for heavy duty service

NCB Ordering Information

Type	Float Size	Part No.	Stem/Float Material	Switch
Top Mount	Intermediate	NCB-1084	316 SS/Buna-N	100 VA, SPST
Top Mount	Intermediate	NCB-1094	Brass/Buna-N	100 VA, SPST
Top Mount	Large	NCB-5124	316 SS/Buna-N	100 VA, SPST
Top Mount	Large	NCB-5134	Brass/Buna-N	100 VA, SPST
Top Mount	Large	NCB-5144	316 SS/Buna-N	20 VA, SPST
Top Mount	Large	NCB-5154	Brass/Buna-N	20 VA, SPST

Specifications

Max. Pressure: 150 PSIG
Operating Temperature Range
In Oil: - 40 °F to 230 °F
In Water: - 40 °F to 180 °F
Fittings: 1/4 NPT
Leads: 18 AWG×24"
Liquid Specific Gravity
Minimum: 0.55



NCS ALL STAINLESS STEEL SWITCHES For High Corrosive, High Temperature Applications

Small Size Models

Features

- Compact size, 1.1" dia. float
- Long operating life
- Highly resistant to shock and vibration
- All wetted parts 316 SS
- Explosion proof version available

Specifications

Max. Pressure: 400 PSIG
Temperature Range: - 40 °F to 300 °F
Fittings: 1/8" NPT
Leads: 22 AWG×24"
Liquid Specific Gravity
Minimum: 0.77

Hazardous Area Classification

NCS-1075: UL Approved
 CLI Div I Gr. C & D
 CLII Div II Gr. A, B, C & D

Large NCS Models

Features

- All wetted parts 316 stainless steel
- High resistance to corrosive chemicals
- Operates in high temperatures
- High pressure capable

Specifications

Max. Pressure: 400 PSIG
Temperature Range: - 40 °F to 300 °F
Fittings
Typical: 1/4" NPT or
NCS-7202: 1/2"-13 UNF
Leads
Standard: 18 AWG×2 feet
Waterproof: 18 AWG×10 feet

Liquid Specific Gravity

Minimum: 0.65

Hazardous Area Classification

NCS 7203
NCS-1075: UL Approved
 CLI Div I Gr. C & D
 CLII Div II Gr. A, B, C & D

Model NCS-1074/NCS-1075 Small Size

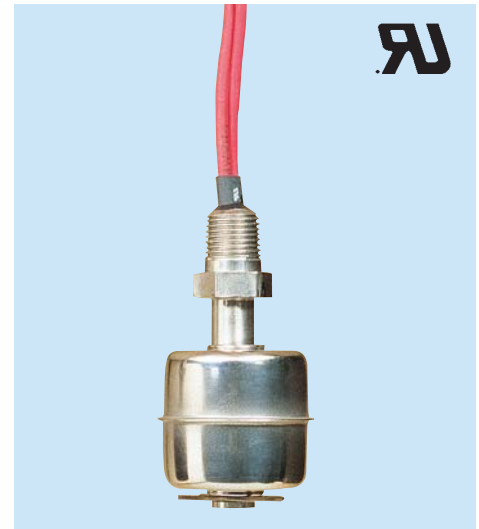
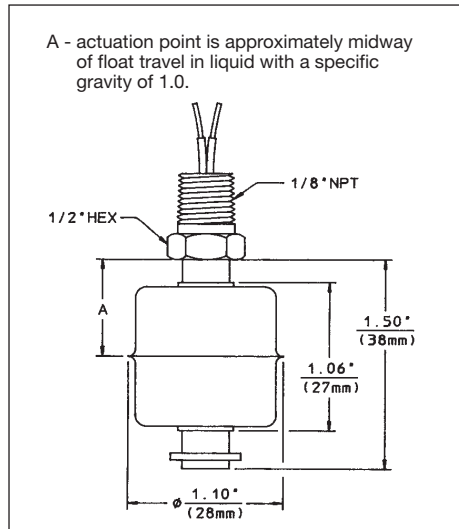

Model NCS Large Size

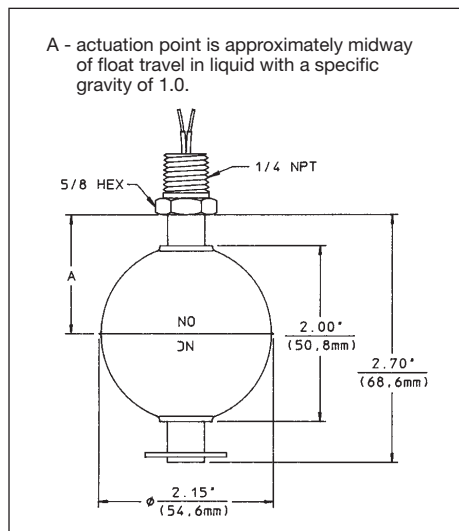

NCS Ordering Information

Size	Type	Part No.	Stem/Float Material	Switch
Small	Standard	NCS-1074	316 SS/316 SS	20 VA, SPST
Small	Explosion Proof NPT	NCS-1075	316 SS/316 SS	20 VA, SPST
Large	Standard	NCS-1104	316 SS/316 SS	100 VA, SPST
Large	Standard	NCS-5214	316 SS/316 SS	20 VA, SPST
Large	Waterproof - NPT	NCS-7201	316 SS/316 SS	20 VA, SPST
Large	Waterproof - UNF	NCS-7202	316 SS/316 SS	20 VA, SPST
Large	Explosion Proof - NPT	NCS-7203	316 SS/316 SS	20 VA, SPST

NC BENT STEM SIDEMOUNT AND PVC SWITCHES

NCS-5161 and NCB-5171 Sidemount Switches

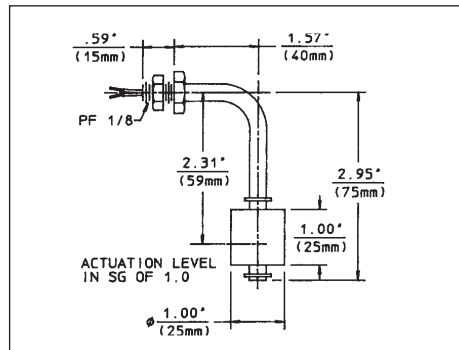
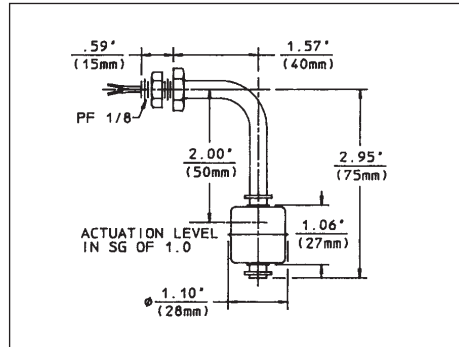

SS NCS-5161 and Buna-N NCB-5171 Sidemount Switches

N1

Features

- 90° bend allows mounting where access to tank top or bottom is restricted
- 316 SS stem standard
- Floats available in SS or Buna-N
- Long operating life

Specifications

Maximum Pressure

- SS:** 275 PSIG
- Buna:** 150 PSIG

Operating Temperature Range

- SS:** - 40 °F to 300 °F
- Buna: In Oil:** - 40 °F to 230 °F
- In Water:** - 40 °F to 180 °F

Fittings:

PF 1/8" (3/8"-24)

Leads:

22 AWG×11"

Minimum Liquid Specific Gravity

- SS:** 0.77
- Buna:** 0.55

NCP-1401 PVC Switches

Ordering Information

Type	Part No.	Stem/Float Material	Switch
Side Mount	NCS-5161	316 SS/316 SS	20 VA, SPST
Side Mount	NCB-5171	316 SS/Buna-N	20 VA, SPST



NCG STANDARD MULTIPOINT LEVEL SWITCHES



The KOBOLD Standard Multipoint Level Switches are available in lengths to 96 inches, with switches located as per your instructions.

Stem Choices

Maximum Length: 96"
Wetted Parts
Stem/Fittings: 316 SS or Brass
Electrical Ratings: SPST, 20 VA, optionally 100 VA

- Special units available to 10 feet.
- Up to 6 control points per unit

Float Choices

Wetted Parts: Buna-N
Stainless Steel

Maximum Pressure
Buna-N: 150 PSIG
Stainless Steel: 400 PSIG
PVC: 100 PSIG

Operating Temperature
Buna-N: In Oil: - 40 °F to 230 °F
In Water: - 40 °F to 180 °F
Stainless Steel: - 40 °F to 300 °F
PVC: - 40 °F to 140 °F

Minimum Liquid Specific Gravity
Type 1 Float: 0.65
Type 2 Float: 0.55
Type 3 Float: 0.55
Type 4 Float: 0.85

Switch Geometry

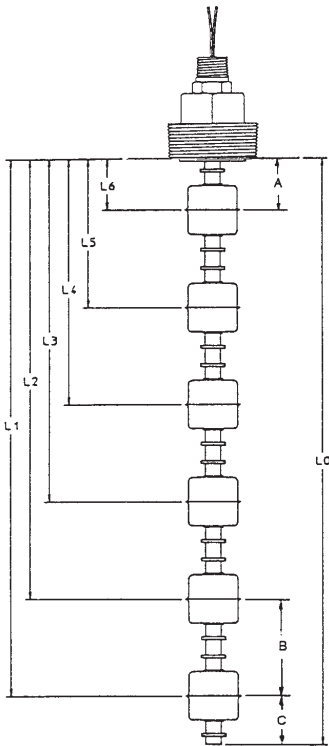

A = 1/2" minimum distance to highest level
 B = 3" minimum distance between levels
 C = 2" minimum distance from end of unit to lowest level

Fitting Choice Selection Table

Fitting Choices	Type 1	Type 2	Type 3	Type 4	Type 5
Fitting	1/2" NPT	1 1/4" NPT	2" NPT	3" ANSI Flange	1/2" Tubing

Float Choice Selection Table

Type 1 Float 316 SS	Type 2 Float Buna-N	Type 3 Float Buna-N	Type 4 Float PVC
2.00" (51mm) ø 2.10" (53mm)	1.75" (44mm) ø 1.19" (30mm)	1.88" (48mm) ø 1.88" (48mm)	1.81" (46mm) ø 1.5" (40mm)



NCG STANDARD MULTIPOINT LEVEL SWITCHES

NCG Ordering Information

NCG-	W = Fitting Type	X = Fitting/ Stem Material	Y = Number of Switch Levels	Z = Float Type & Material	Options
	W = 1: 1/2" NPT Male	X = 1: Brass/Brass	Y = 1-6	Z = 1: Stainless Steel (Fitting Types 1, 3, 4 and 5)	-A: Adjustable Fitting (Fitting Types 2, 3, and 4, not w/PVC)
	W = 2: 1 1/4" NPT with 1/2" NPT Conduit	X = 2: SS/SS	Specify Number of Levels	Z = 2: Small Buna-N	-B: Weighted Buna-N floats for interface detection (Specify desired float S. G.)
	W = 3: 2" NPT with 1/2" NPT Conduit	X = 3: PVC/PVC (Stem Type 1, 3 and 4 only)		Z = 3: Large Buna-N (Fitting Types 1, 3, 4 and 5)	-D4: Group IV Wiring 20 VA, SPDT (Not UL recognized)
	W = 4: 3" ANSI Flange SS & PVC only			Z = 4: PVC (For PVC Stem only)	-H: 100 VA SPST (Not UL recognized) (Not for Stem 3) Reed Switch (Not UL recognized)
	W = 5: 1/2" Tube End				-N: Junction Box NEMA 4 -NT: Junction Box w/Terminal Strip NEMA 4

N1

How to Order

Before ordering, it is important to thoroughly define your level switch requirements. Simply follow the instructions given in this section, paying special attention to steps 1-4. Note that:

- Switch operation is defined as »normal« when the float is dry, and the container is empty.
- Standard lead wires are 24 inches long, 22 AWG.
- Standard wiring is Group II.

1. Select the stem type.
2. Select the stem material.
3. Specify the number of switch levels needed and define their operation by completing the »Actuation Point Location and Logic« section below.
4. Choose the type of float desired and complete the »Application Information« section below to assure suitability.
5. Determine voltage and current to be switched. If necessary, order the

- optional high power 100 VA reed switch or an isolation relay such as the RL-6101.
6. Specify all other options desired.
7. Determine the number of complete units required.
8. Make a copy of the completed »Actuation Point Location and Logic« and »Application Information« tables below, and include with your order.

Actuation Point Location and Logic

Distance (inches)	SPST Switch Operation	
L0: = (L1 + 2")		
L1: _____	NO Dry: _____	NC Dry: _____
L2: _____	NO Dry: _____	NC Dry: _____
L3: _____	NO Dry: _____	NC Dry: _____
L4: _____	NO Dry: _____	NC Dry: _____
L5: _____	NO Dry: _____	NC Dry: _____
L6: _____	NO Dry: _____	NC Dry: _____

Application Information

Process Liquid: Name: _____

Specific Gravity: _____

Viscosity: _____

Temperature: Operating: _____

Maximum: _____

Minimum: _____

Pressure: Operating: _____

Maximum: _____

Tank Material: _____

NOTE: 3" minimum distance between levels.

Subject to change without prior notice.



NCM MINIATURE LEVEL SWITCHES



The KOBOLD Miniature Multipoint Level Switches are available in lengths to 48 inches. Up to five switches may be located as per your instructions.

Electrical Ratings

Contact Type: SPST, 20VA, optionally 100 VA

Maximum Levels

Group II Wiring (Standard): 3
Group I Wiring: 5
Lead Wires: 22AWG, 24 inches long

Stem Choices

Maximum Length: 48"
Wetted Parts Stem/Fittings: 316 SS, Brass
Float Stops Brass Units: Brass
SS Units: 316 SS
 ● Up to 48" overall length
 ● Up to 5 control points

Float Choices

Maximum Pressure:
Buna-N, Polypro: 150 PSIG
Stainless Steel: 270 or 400 PSIG
Operating Temperature
Buna-N: In Oil: -40 °F to 225 °F
In Water: -40 °F to 180 °F
Polypropylene: -40 °F to 150 °F
Stainless Steel: -40 °F to 300 °F
Minimum Liquid Specific Gravity
Type 1 Float: 0.77
Type 2 Float: 0.55
Type 3 Float: 0.81
Type 4 Float: 0.70

Switch Geometry

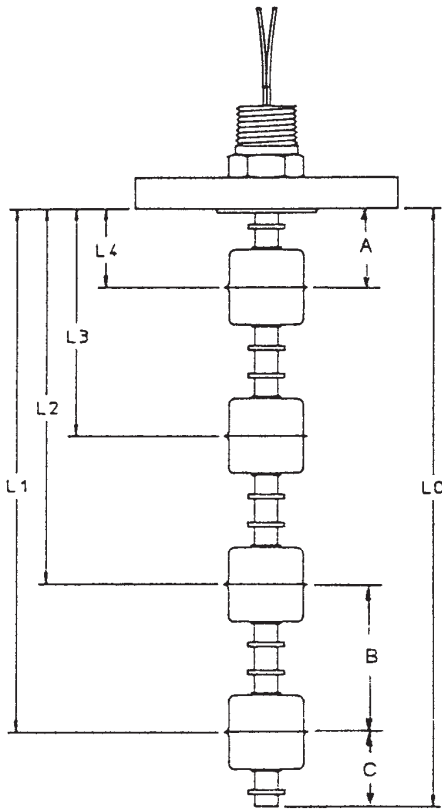

A = 3/4" minimum distance to highest level
 B = 1 1/2" minimum distance between levels
 C = 1" minimum distance from end of unit to lowest level except float type 4, 2" min. distance

Fitting Choice Selection Table

Stem Choices	Type 1	Type 2	Type 3	Type 4	Type 5
Fitting	1/8" NPT	1/4" NPT	1" NPT	3/4" NPT	5/16" Tubing

Float Choice Selection Table

Type 1 Float 316 SS/270 PSIG	Type 2 Float Buna-N	Type 3 Float Polypropylene	Type 4 Float 304 SS/400 PSIG



NCM MINIATURE MULTIPOINT LEVEL SWITCHES

NCM Ordering Information

N1

NCM-	W = Fitting Type	X = Fitting & Stem Material	Y = Number of Switch Levels	Z = Float Type & Material	Options
	W = 1: 1/8" NPT Male	X = 1: Brass/Brass	Y = 1-5	Z = 1: 316 Stainless Steel	-D1: Group I Wiring 100 VA, SPST
	W = 2: 1/4" NPT Male	X = 2: Stainless Steel/ Stainless Steel	Specify Number of Levels	Z = 2: Buna-N	-E: 1/2" Conduit Fitting (Fitting Type 3 only)
	W = 3: 1" NPT Male			Z = 3: Polypropylene	-N: Junction Box NEMA 4
	W = 4: 3/4" NPT Male			Z = 4: 316 Stainless Steel	-NT: Junction Box with Terminal Strip (Fitting Type 3 only) (Requires Option E)
	W = 5: 5/16" Tube End				

How to Order

Before ordering, it is important to thoroughly define your level switch requirements. Simply follow the instructions given in this section, paying special attention to steps 1-4. Note that:

- Switch operation is defined as »normal« when the float is dry, and the container is empty.
- Standard lead wires are 24 inches long, 22 AWG.
- Standard wiring is Group II.

1. Select the stem type.
2. Select the stem material.
3. Specify the number of switch levels needed and define their operation by completing the »Actuation Point Location and Logic« section below.
4. Choose the type of float desired and complete the »Application Information« section below to assure suitability.
5. Determine voltage and current to be switched. If necessary, order an

- isolation relay such as the RL-6101.
6. Specify all other options desired.
7. Determine the number of complete units required.
8. Make a copy of the completed »Actuation Point Location and Logic« and »Application Information« tables below, and include with your order.

Actuation Point Location and Logic

Distance (inches)	SPST Switch Operation	
L0: = (L1 + 1")		
L1: _____	NO Dry: _____	NC Dry: _____
L2: _____	NO Dry: _____	NC Dry: _____
L3: _____	NO Dry: _____	NC Dry: _____
L4: _____	NO Dry: _____	NC Dry: _____
L5: _____	NO Dry: _____	NC Dry: _____

Application Information

Process Liquid: Name: _____

Specific Gravity: _____

Viscosity: _____

Temperature: Operating: _____

Maximum: _____

Minimum: _____

Pressure: Operating: _____

Maximum: _____

Tank Material: _____

NOTE: 1 1/2" minimum distance between levels.

Subject to change without prior notice.