

# RCM DIRECT READING FLOWMETER



Flow  
Pressure  
Level  
Temperature  
measurement  
monitoring  
control



### Special Features

- Compact Design
- Easy to Install
- For Horizontal or Vertical Pipes
- Rugged Construction
- Accuracy:  $\pm 3\%$  Full Scale
- Rangeability 6:1
- Flow Rates up to 3000 GPM Liquid or 20 000 SCFM Gas
- Low Pressure Drop
- Optional Alarms and Output Signals

S5



### USA

KOBOLD Instruments Inc.  
1801 Parkway View Drive  
USA-Pittsburgh, PA 15205  
☎ +1 412-788-2830  
Fax +1 412-788-4890  
E-mail: info@koboldusa.com



### CANADA

KOBOLD Instruments Canada Inc.  
9A Aviation  
Pointe-Claire, QC H9R 4Z2  
☎ +1 514-428-8090  
Fax +1 514-428-8899  
E-mail: kobold@kobold.ca

Visit KOBOLD Online at  
[www.kobold.com](http://www.kobold.com)

Model:  
RCM

The RCM is a differential pressure direct reading flowmeter. It is suitable for monitoring all liquids and gases that have low or medium viscosity, low solids content, and are compatible with the materials of construction. The meter features rugged, compact construction. In liquid applications of 6 GPM and higher, pulsation snubbers are incorporated into the connecting pressure passages to produce smooth meter operation independent of pipeline turbulence.

This meter was developed for industrial flow metering applications in which durability and reliability are important considerations. Accuracy, small size, low cost, minimal maintenance and resistance to accidental damage are the prime goals in the RCM design. Typical applications include: lube oil and cooling water monitoring, blending processes, reverse osmosis systems, and compressed air measurement.

The RCM is available with a 4–20 mA output for interfacing with remote displays and controllers. Limit switches are available to provide high and low limit signals. A 0–1000 Hz frequency output is available to drive frequency based controllers and counters.

### Specifications

- Accuracy:** ± 3% Full Scale
- Flow Media:** Liquids and Gases
- Mounting:** Horizontal or Vertical
- Temperature Range (Ambient and Process)**
  - Standard:** – 30 to 212 °F
  - Optional:** – 80 to 350 °F
- Maximum Pressure**
  - Standard:** 180 PSIG
  - Optional:** 400 PSIG
- Housing:** Polycarbonate  
UV stabilized
- Body:** Bronze, Monel, or 316 SS
  - Option -ES:** also Teflon™
- Bellows:** Bronze, Monel  
316 SS or Inconel™
- Movement:** Bronze or SS
- Seals:** Buna-N, Viton, EPDM  
or Teflon™
- Crystal:** Polycarbonate
- Relay Options:** High/Low Alarms
- Output Options:** 4–20mA  
0–1000 Hz Frequency



Model RCM-7126

### Ordering Information

Order **RCM Series Flowmeter** by:

- 1) choose range and material for wetted part on order number tables
- 2) choose options (if required)
- 3) specify direction of flow according to Flow Direction instructions below.

**Flow Direction:**

- R Horizontal, flow to right
- L Horizontal, flow to left
- VUR Vertical, flow up, dial at right
- VDR Vertical, flow down, dial at right
- VUL Vertical, flow up, dial at left
- VDL Vertical, flow down, dial at left

**Example:**

RCM-7117-A-D-R is the catalog no. for a 3/4" NPT RCM Series 7000 Flowmeters of bronze construction, flow direction from left to right, flow rating of 20 GPM (full scale), equipped with optional seals of Viton and optional gasketed case.

**Options** (if required).

- 1S2 Single SPDT Reed switch
- 2S2 Dual SPDT Reed switch
- A Viton seals
- B Customer-specified seals
- C Calibration for specific gravity
- D Gasketed case
- E Non-standard flow rate
- ES Low flow rate
- G Custom scales and dials
- H 400 psig service
- K Steam service (SS only)
- N Ammonia service
- O2 Oxygen cleaning
- P Panel mounting kit
- R LCD rate & total display
- T 350 °F service rating
- V Calibration for high viscosity
- W 4-20 mA dc
- W2 4-20 mA DP Transmitter
- W3 4-20 mA Blind DP Transmitter
- X Hi/Lo alarm relays
- Y 1000 Hz full scale frequency
- Z Comb. of options W, X, Y

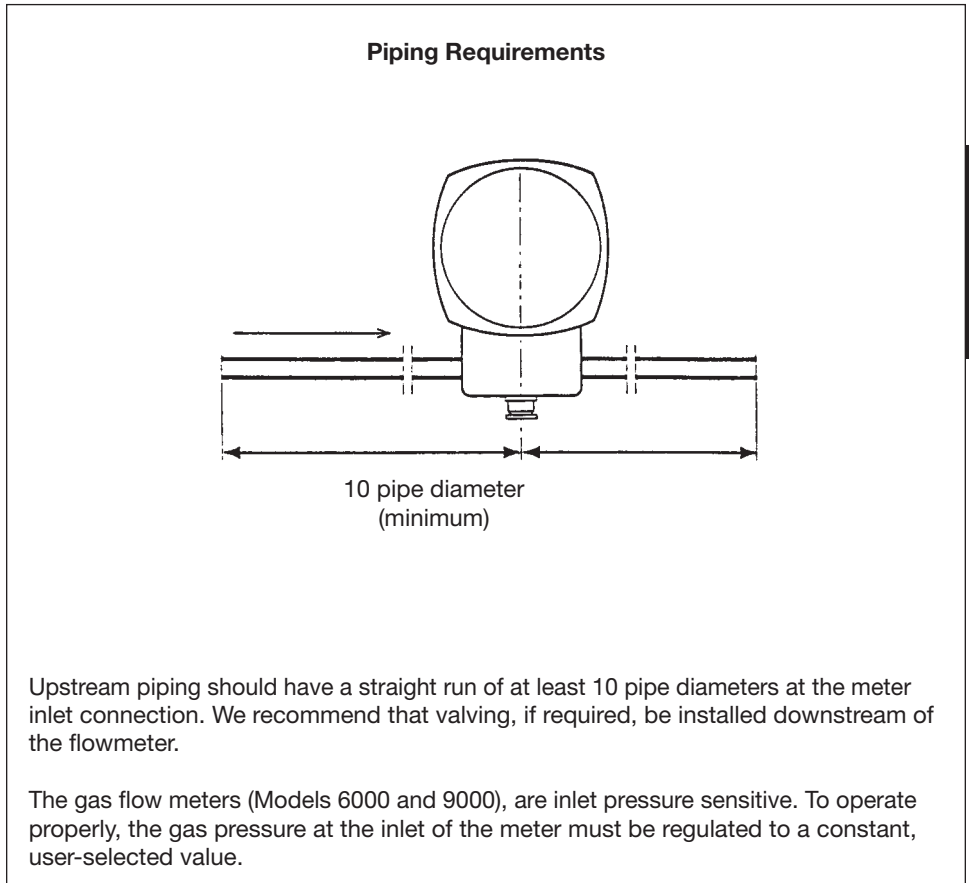
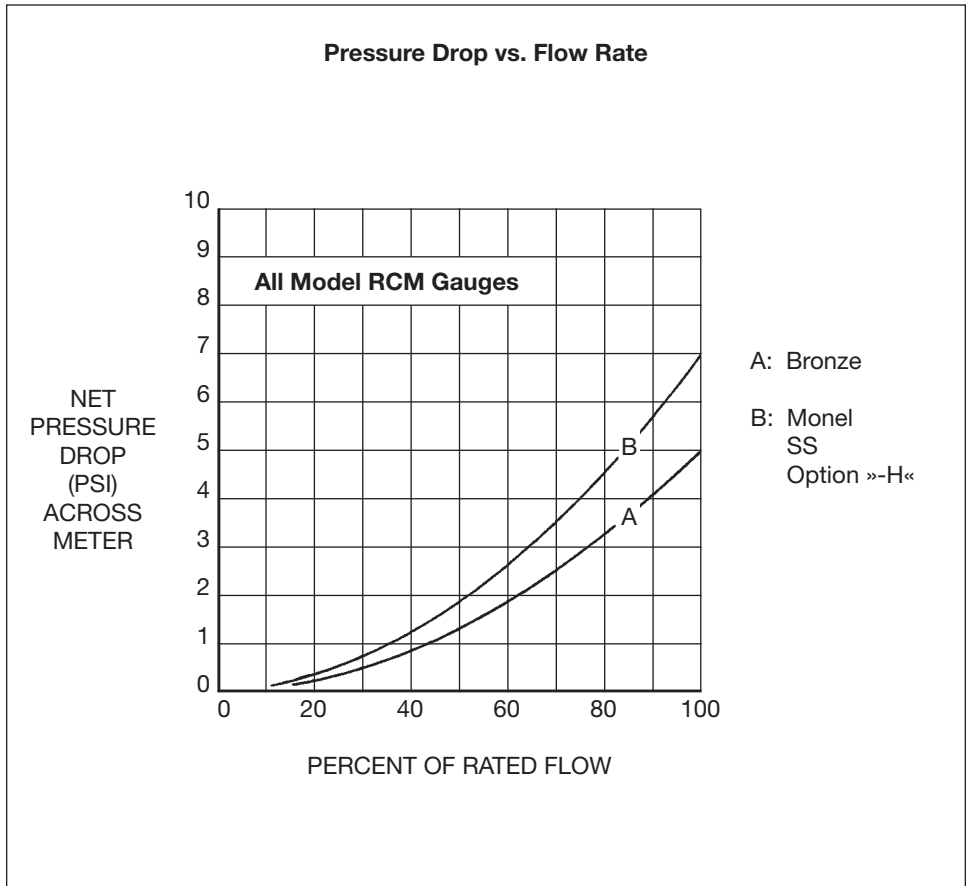

S5



Ordering Data for Threaded Liquid Flowmeters						
Range GPM Liquid	Fittings NPT	Ordering Number of Desired Material			Low Flow Option Add Suffix »ES«	Other Options
		Bronze	Monel	Stainless Steel	Range GPH	
0.3- 2.0	1/4"	RCM-7101	RCM-7201	RCM-7301		See Options Table
0.3- 2.0	1/2"	RCM-7102	RCM-7202	RCM-7302	0.5- 4.0	
0.4- 3.0	1/4"	RCM-7103	RCM-7203	RCM-7303		
0.5- 3.0	1/2"	RCM-7104	RCM-7204	RCM-7304	0.5- 6.0	
0.6- 4.0	1/4"	RCM-7105	RCM-7205	RCM-7305		
0.5- 4.0	1/2"	RCM-7106	RCM-7206	RCM-7306	1.5- 10	
0.6- 6.0	1/2"	RCM-7107	RCM-7207	RCM-7307	2.0- 15	
0.6- 6.0	3/4"	RCM-7108	RCM-7208	RCM-7308		
1.5- 10	1/2"	RCM-7109	RCM-7209	RCM-7309	3.0- 20	
1.5- 10	3/4"	RCM-7110	RCM-7210	RCM-7310		
-	1/2"	RCM-7111	RCM-7211	RCM-7311	4.0- 30	
-	1/2"	RCM-7112	RCM-7212	RCM-7312	5.0- 40	
-	1/2"	RCM-7113	RCM-7213	RCM-7313	8.0- 60	
-	1/2"	RCM-7114	RCM-7214	RCM-7314	15 -100	
2.0- 15	3/4"	RCM-7115	RCM-7215	RCM-7315		
2.0- 15	1"	RCM-7116	RCM-7216	RCM-7316		
3.0- 20	3/4"	RCM-7117	RCM-7217	RCM-7317		
3.0- 20	1"	RCM-7118	RCM-7218	RCM-7318		
4.0- 30	1"	RCM-7119	RCM-7219	RCM-7319		
4.0- 30	1 1/2"	RCM-7120	RCM-7220	RCM-7320		
5.0- 40	1"	RCM-7121	RCM-7221	RCM-7321		
5.0- 40	1 1/2"	RCM-7122	RCM-7222	RCM-7322		
5.0- 40	2"	RCM-7123	RCM-7223	RCM-7323		
5.0- 60	1 1/2"	RCM-7124	RCM-7224	RCM-7324		
5.0- 60	2"	RCM-7125	RCM-7225	RCM-7325		
15 -100	1 1/2"	RCM-7126	RCM-7226	RCM-7326		
15 -100	2"	RCM-7127	RCM-7227	RCM-7327		
20 -150	2"	RCM-7128	RCM-7228	RCM-7328		
30 -200	2"	RCM-7129	RCM-7229	RCM-7329		
30 -200	3"	RCM-7130	-	RCM-7330		
40 -300	3"	RCM-7131	-	RCM-7331		
50 -400	3"	RCM-7132	-	RCM-7332		
50 -500	3"	RCM-7133	-	RCM-7333		

A minimum of 10 PSIG of back pressure is required for the RCM to be suitable for use with your application.

Order Numbers are a combination of the part number in the above table, and the Suffix designation for the desired options.

Example: A 1/4" Monel unit for 0.4-3.0 GPM Water with Viton seals, flow right to left:

Order Number = RCM-7203 + A + L = RCM-7203-A-L.

When ordering, specify: Name of medium, viscosity and specific gravity if medium is other than water.

Ordering Data for Threaded Gas Flowmeters						
Range SCFM Gas  (10 PSIG Minimum)	Fittings NPT	Ordering Number of Desired Material			Low Flow Option Add Suffix »ES«	Other Options
		Bronze	Monel	Stainless Steel	Range SCFH	
1.5– 10	1/4"	RCM-9101	RCM-9201	RCM-9301		See Options Table
1.5– 10	1/2"	RCM-9102	RCM-9202	RCM-9302	5.0– 40	
3.0– 20	1/4"	RCM-9103	RCM-9203	RCM-9303		
3.0– 20	1/2"	RCM-9104	RCM-9204	RCM-9304	8.0– 60	
4.0– 30	1/4"	RCM-9105	RCM-9205	RCM-9305		
4.0– 30	1/2"	RCM-9106	RCM-9206	RCM-9306	15 –100	
5.0– 40	1/2"	RCM-9107	RCM-9207	RCM-9307	20 –150	
5.0– 40	3/4"	RCM-9108	RCM-9208	RCM-9308		
8.0– 60	1/2"	RCM-9109	RCM-9209	RCM-9309	30 –200	
8.0– 60	3/4"	RCM-9110	RCM-9210	RCM-9310		
–	1/2"	RCM-9111	RCM-9211	RCM-9311	40 –300	
–	1/2"	RCM-9112	RCM-9212	RCM-9312	50 –400	
15 – 100	3/4"	RCM-9113	RCM-9213	RCM-9313		
15 – 100	1"	RCM-9114	RCM-9214	RCM-9314		
20 – 150	3/4"	RCM-9115	RCM-9215	RCM-9315		
20 – 150	1"	RCM-9116	RCM-9216	RCM-9316		
30 – 200	3/4"	RCM-9117	RCM-9217	RCM-9317		
30 – 200	1"	RCM-9118	RCM-9218	RCM-9318		
30 – 200	1 1/2"	RCM-9119	RCM-9219	RCM-9319		
40 – 300	1"	RCM-9120	RCM-9220	RCM-9320		
40 – 300	1 1/2"	RCM-9121	RCM-9221	RCM-9321		
50 – 400	1"	RCM-9122	RCM-9222	RCM-9322		
50 – 400	1 1/2"	RCM-9123	RCM-9223	RCM-9323		
50 – 400	2"	RCM-9124	RCM-9224	RCM-9324		
50 – 600	1 1/2"	RCM-9125	RCM-9225	RCM-9325		
50 – 600	2"	RCM-9126	RCM-9226	RCM-9326		
100 – 800	1 1/2"	RCM-9127	RCM-9227	RCM-9327		
100 – 800	2"	RCM-9128	RCM-9228	RCM-9328		
150 –1000	2"	RCM-9129	RCM-9229	RCM-9329		
150 –1000	3"	RCM-9130	–	RCM-9330		
300 –2000	3"	RCM-9131	–	RCM-9331		
400 –3000	3"	RCM-9132	–	RCM-9332		
500 –4000	3"	RCM-9133	–	RCM-9333		

S5

As with all Kobold model RCM flowmeters, a minimum of 10 PSIG back pressure is required for proper operation.

Order Numbers are a combination of the part number in the above table, and the Suffix designation for the desired options.

Example: A 1/2" Bronze unit for 4.0–30 SCFM Air at 400 PSIG and 350 °F, flow down at left:

Order Number = RCM-9106 + H + T + VDL = RCM-9106-H-T-VDL

When ordering, specify: Type of gas, operating inlet pressure and temperature.



Ordering Data for Wafer Style Liquid Flowmeters						
Range GPM Liquid	Fittings Flange Size	Ordering Number of Desired Material				Other Options
		Bronze	Monel	Stainless Steel		
0.3- 2.0	1/2"	RCM-5102	RCM-5202	RCM-5302		See Options Table
0.4- 3.0	1/2"	RCM-5104	RCM-5204	RCM-5304		
0.5- 4.0	1/2"	RCM-5106	RCM-5206	RCM-5306		
0.6- 6.0	1/2"	RCM-5107	RCM-5207	RCM-5307		
0.6- 6.0	3/4"	RCM-5108	RCM-5208	RCM-5308		
1.5- 10	1/2"	RCM-5109	RCM-5209	RCM-5309		
1.5- 10	3/4"	RCM-5110	RCM-5210	RCM-5310		
2.0- 15	3/4"	RCM-5115	RCM-5215	RCM-5315		
2.0- 15	1"	RCM-5116	RCM-5216	RCM-5316		
3.0- 20	3/4"	RCM-5117	RCM-5217	RCM-5317		
3.0- 20	1"	RCM-5118	RCM-5218	RCM-5318		
4.0- 30	1 1/2"	RCM-5120	RCM-5220	RCM-5320	Extended Flange Size Add Suffix: -EF1 = 2 1/2" -EF2 = 5"	
5.0- 40	1"	RCM-5121	RCM-5221	RCM-5321		
5.0- 40	1 1/2"	RCM-5122	RCM-5222	RCM-5322		
5.0- 40	2"	RCM-5123	RCM-5223	RCM-5323		
5.0- 60	1 1/2"	RCM-5124	RCM-5224	RCM-5324		
5.0- 60	2"	RCM-5125	RCM-5225	RCM-5325	-EF1	
15 - 100	1 1/2"	RCM-5126	RCM-5226	RCM-5326		
15 - 100	2"	RCM-5127	RCM-5227	RCM-5327	-EF1	
20 - 150	2"	RCM-5128	RCM-5228	RCM-5328	-EF1	
30 - 200	2"	RCM-5129	RCM-5229	RCM-5329	-EF1	
30 - 200	3"	RCM-5130	RCM-5230	RCM-5330		
40 - 300	3"	RCM-5131	RCM-5231	RCM-5331		
50 - 400	3"	RCM-5132	RCM-5232	RCM-5332		
50 - 500	3"	RCM-5133	RCM-5233	RCM-5333		
40 - 300	4"	RCM-5134	-	RCM-5334	-EF2	
50 - 400	4"	RCM-5135	-	RCM-5335	-EF2	
50 - 600	4"	RCM-5136	-	RCM-5336	-EF2	
50 - 600	6"	RCM-5137	-	RCM-5337		
50 - 600	8"	RCM-5138	-	RCM-5338		
100 - 800	4"	RCM-5139	-	RCM-5339	-EF2	
100 - 800	6"	RCM-5140	-	RCM-5340		
150 -1000	6"	RCM-5141	-	RCM-5341		
150 -1000	8"	RCM-5142	-	RCM-5342		
300 -2000	6"	RCM-5143	-	RCM-5343		
300 -2000	8"	RCM-5144	-	RCM-5344		
400 -3000	8"	RCM-5145	-	RCM-5345		

Order Numbers are a combination of the part number in the above table, and the Suffix designation for the desired options.

Example: A 4" Bronze unit for 800 GPM Water with Viton seals, flow up dial at right:

Order Number = RCM-5139 + A + VUR = RCM-5139-A-VUR

When ordering, specify: Name of medium, viscosity and specific gravity if medium is other than water.



Ordering Data for Wafer Style Gas Flowmeters						
Range SCFM Gas  (10 PSIG Minimum)	Fittings Flange Size	Ordering Number of Desired Material			Other Options	
		Bronze	Monel	Stainless Steel		
1.5- 10 4.0- 30 5.0- 40 8.0- 60 8.0- 60	1/2" 1/2" 1/2" 1/2" 3/4"	RCM-6102 RCM-6106 RCM-6107 RCM-6109 RCM-6110	RCM-6202 RCM-6206 RCM-6207 RCM-6209 RCM-6210	RCM-6302 RCM-6306 RCM-6307 RCM-6309 RCM-6310	See Options Table	
15 - 100 20 - 150 20 - 150	3/4" 3/4" 1"	RCM-6113 RCM-6115 RCM-6116	RCM-6213 RCM-6215 RCM-6216	RCM-6313 RCM-6315 RCM-6316		
30 - 200 30 - 200 40 - 300 40 - 300 50 - 400	3/4" 1" 1" 1 1/2" 1"	RCM-6117 RCM-6118 RCM-6120 RCM-6121 RCM-6122	RCM-6217 RCM-6218 RCM-6220 RCM-6221 RCM-6222	RCM-6317 RCM-6318 RCM-6320 RCM-6321 RCM-6322		Extended Flange Size Add Suffix: -EF1 = 2 1/2" -EF2 = 5"
50 - 400 50 - 400 50 - 600 50 - 600 100 - 800	1 1/2" 2" 1 1/2" 2" 1 1/2"	RCM-6123 RCM-6124 RCM-6125 RCM-6126 RCM-6127	RCM-6223 RCM-6224 RCM-6225 RCM-6226 RCM-6227	RCM-6323 RCM-6324 RCM-6325 RCM-6326 RCM-6327		
100 - 800 150 - 1000 150 - 1000 150 - 1200 200 - 1500	2" 2" 3" 2" 4"	RCM-6128 RCM-6129 RCM-6130 RCM-6161 RCM-6134	RCM-6228 RCM-6229 RCM-6230 RCM-6261 -	RCM-6328 RCM-6329 RCM-6330 RCM-6361 RCM-6334		-EF1 -EF1 -EF1 -EF2
300 - 2000 400 - 3000 400 - 3000 400 - 3000 500 - 4000	3" 3" 4" 6" 3"	RCM-6131 RCM-6132 RCM-6135 RCM-6136 RCM-6133	RCM-6231 RCM-6232 - - RCM-6233	RCM-6331 RCM-6332 RCM-6335 RCM-6336 RCM-6333		-EF2
600 - 5000 600 - 5000 600 - 5000 800 - 6000 1000 - 8000	4" 6" 8" 4" 6"	RCM-6137 RCM-6138 RCM-6139 RCM-6140 RCM-6141	- - - - -	RCM-6337 RCM-6338 RCM-6339 RCM-6340 RCM-6341		-EF2 -EF2
1000 - 8000 2000 -15000 2000 -15000 3000 -20000	8" 6" 8" 8"	RCM-6142 RCM-6143 RCM-6144 RCM-6145	- - - -	RCM-6342 RCM-6343 RCM-6344 RCM-6345		

S5

Kobold model RCM-5000 & 6000 series flowmeters are designed for wafer style mounting between two adjoining flanges. As with all model RCM meters, a minimum of 10 PSIG back pressure is required for operation. The meter will fit between all standard 150 lb or 300 lb ANSI flanges, DIN PN 10 or PN 16 flanges, JIS and AS flanges. Installation requires flanges, flat gaskets and flange bolts provided by the user.

Order Numbers are a combination of the part number in the above table, and the Suffix designation for the desired options.  
 Example: A 6" Stainless Steel unit for 5000 SCFM Air with 4-20 mA transmitter and NEMA 4 gasketed case, flow to the right is:  
 Order Number = RCM-6338 + D2 + W-R = RCM-6338-D2-W-R.  
 When ordering, specify: Type of gas, operating inlet pressure and temperature.

## Output Specifications

### Output Combinations

Output options may be combined in any fashion desired. However, choice on an electronic output option does limit the choice of other options. In particular, choice of option W, W2, W3, X or Y, precludes the selection of the following options:

- **Option D:** Gasketed Case
- **Option K:** Steam Service
- **Option N:** Ammonia Service
- **Option T:** High Temperature
- **Option 1S2:** Single SPDT Switch
- **Option 2S2:** Dual SPDT Switch

### General to All Output Options

**Electrical Rating:** Gen. Purpose

**Power Requirements:**  
24 VDC  $\pm$  10 %

### Accuracy of Gauge with Outputs

**Horizontal flow:**  $\pm$  3 % F. S.

**Vertical flow:**  $\pm$  5 % F. S.

### Maximum Temperature

**Ambient:** - 30 to 120 °F

**Medium:** - 30 to 212 °F



## Option Ordering Information

Option	Description
1S2	Single SPDT Reed Switch, 3 W max, effective 30–90 % of full scale (except options K, N, T, W, X, Y, Z)
2S2	Dual SPDT Reed Switches, 3 W max, effective 30–90 % of full scale (except options K, N, T, W, X, Y, Z)
A	Viton elastomer seals
B	Customer specified elastomer seals
C	Calibrate for liquid specific gravity (SG < 0.95 or SG > 1.05)
D	Gasketed meter case, NEMA 4X (except options W, X, Y, Z)
D2	Gasketed case with conduit, NEMA 4X (options W, X, Y, Z)
E	Non-standard flow rate (special orifice)
EM	European Labeling w/ CE
ES	Low flow option
H	400 psig service rating
J	Peak Flow Indicator
K	Steam Service (SS units only, 120 PSIG max, 350 °F service rating)
N	Ammonia service (Available with stainless steel only; not available with options W, X, Y, Z, 1S2, 2S2)
O2	Oxygen cleaning per ASTM G93-88
P	Panel mounting kit (only 1" and smaller)
R	LCD rate & total display, replaces analog dial, requires option W3 (except options K, N, T, 1S2, 2S2)
T	350 °F service rating (except options W, X, Y, Z)
V	Calibration for high viscosity liquid (5 cPs < viscosity < 500 cPs)
W	4–20 mA dc flow rate transmitter output, 24 VDC (except options K, N, T, 1S2, 2S2)
W2	4–20 mA $\Delta$ P transmitter with mechanical indicator (except options K, N, T, 1S2, 2S2, max. $\Delta$ P = 58 PSI)
W3	4–20 mA $\Delta$ P transmitter without indicator (except options K, N, T, 1S2, 2S2)
X	Two set point switches (Hi/Lo), 24 VDC (except options K, N, T, 1S2, 2S2)
Y	Frequency output 1000 Hz F. S., 24 VDC (except options K, N, T, 1S2, 2S2)
Z	Options W, X and Y combined (100 mA combined current draw)

### Output Options

The RCM offers five powered output configurations to allow connection to a variety of electronic process control equipment. The position of the indicator arm is read by a Hall sensor and translated into the required electrical signal:

- Option W: 4–20 mA Flow Rate Transmitter
- Option W2: 4–20 mA Differential Pressure Transmitter
- Option W3: 4–20 mA Differential Pressure Transmitter w/o Indicator (Blind transmitter)
- Option X: High and Low Alarm Relay Output
- Option Y: 0–1000 Hz Frequency Output
- Option Z: Options W, X & Y combined

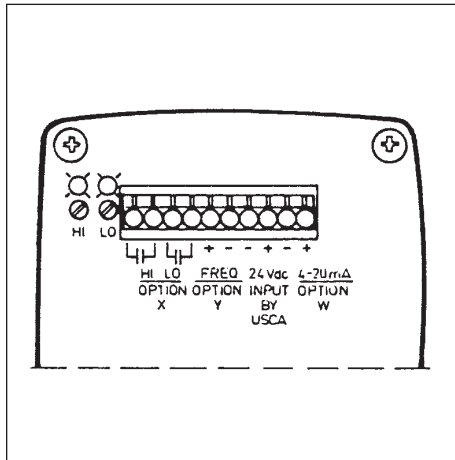
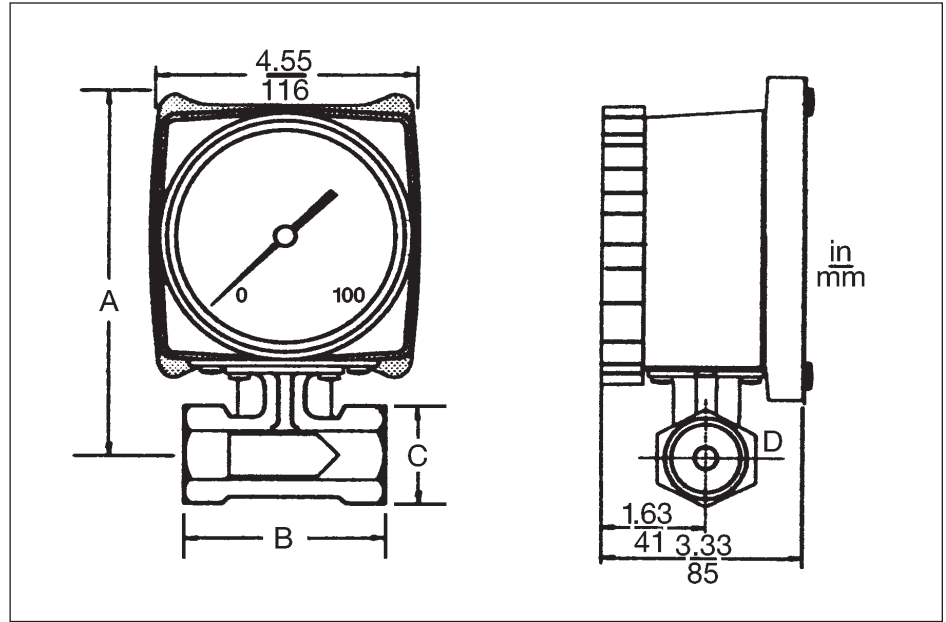

Body Size (IPS)	Dimensions				Net Weight (lbs)
	A	B	C	D	
1/4"	5.20"	3.06"	1.06"	1 1/16" Sq.	3.5
1/2"	5.20"	3.06"	1.06"	1 1/16" Sq.	3.5
3/4"	5.95"	3.06"	1.50"	1 1/4" Hex	3.6
1"	6.07"	3.06"	1.75"	1 1/2" Hex	3.8
1 1/2"	6.39"	3.06"	2.50"	2 1/8" Hex	4.5
2"	6.80"	3.19"	3.19"	2 3/4" Hex	6.1
3"	7.48"	4.19"	4.62"	4" Hex	13.0

### Output Specifications

#### Analog Output: Option W Output

- Signal:** 4–20 mA Proportional to Flow
- Load:** 800 Ohms max.
- Zero:** 15% of Full Scale
- Span:** 30% to 100% of Full Scale Flow
- Power:** 24 VDC ± 10%  
50 mA max.

#### Analog Output: Option W2/W3 Output

- Output:** 4–20 mA Proportional to Differential Pressure
- Load:** 250 Ohms max.
- Span:** 15% to 100% of Full Scale Orifice ΔP
- Power:** 24 VDC ± 10%

#### Alarm Relays: Option X

Two N/O limit relays are provided; one relay is configured as a minimum and the other as a maximum. Red and green LEDs indicate relay operation.

- Output:** 2 N/O Limit Relays
- Power:** 24 VDC ± 10%  
50 mA max.

#### Contact Rating

- AC:** 3.0 A @ 24 VAC  
1.0 A @ 117 VAC  
0.5 A @ 230 VAC
- DC:** 2.0 A @ 30 VDC  
0.6 A @ 110 VDC  
0.5 A @ 140 VDC

#### Frequency Output: Option Y

A 0–1000 Hz frequency output is available to drive pulse triggered controllers. The usable range is 30% to 100% of full scale flow.

- Output:** Frequency signal  
0–1000 Hz  
5 V peak
- Zero:** 15% of Full Scale
- Span:** 30% to 100% of Full Scale Flow
- Power:** 24 VDC ± 10%  
50 mA max.

## Dimensions of Wafer Style Meters

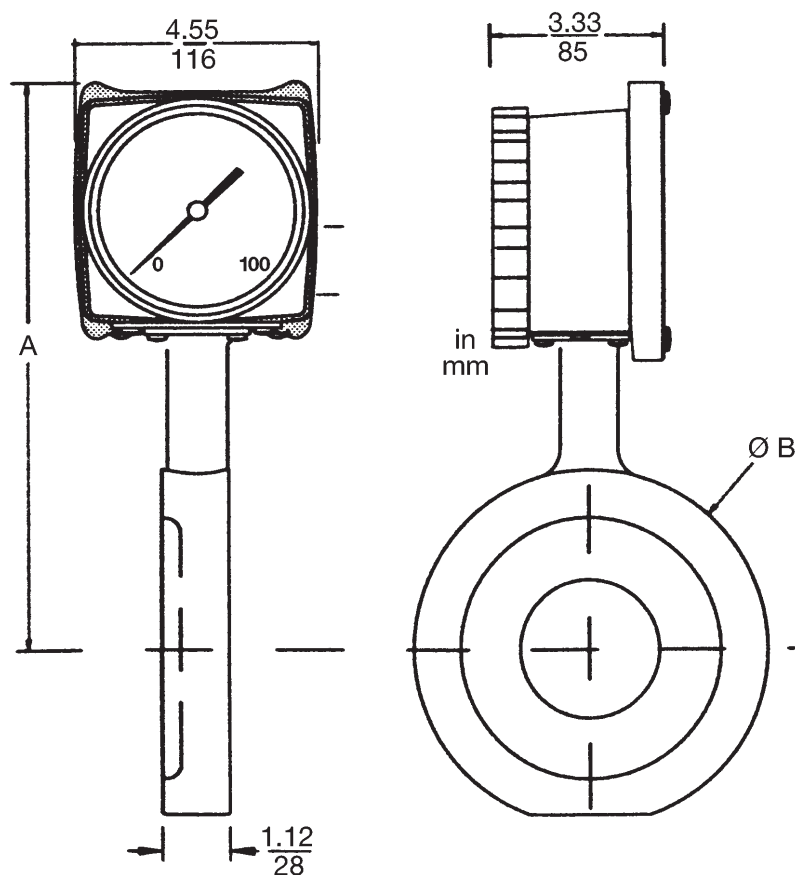

Size		Dimensions				Net Weight	
		A		B			
in	mm	in	mm	in	mm	lbs	kg
1/2	15	6.62	168	1.69	43	4	1.8
3/4	20	7.06	179	2.00	51	5	2.3
1	25	7.25	184	2.38	60	5	2.3
1 1/2	40	7.81	198	3.12	79	6	2.7
2	50	8.00	203	3.75	95	7	3.2
3	80	8.87	225	5.00	127	9	4.1
4	100	9.95	252	6.13	156	12	5.4
6	150	11.05	280	8.38	213	16	7.3
8	200	12.30	311	10.38	264	24	11

Kobold wafer style RCM flowmeters are designed for mounting between two adjoining flanges. The meter will fit between all standard 150 lb or 300 lb ANSI flanges, DIN PN 10 or PN 16 flanges, JIS and AS flanges.

Installation requires flanges, flat gaskets and flange bolts provided by the user.