

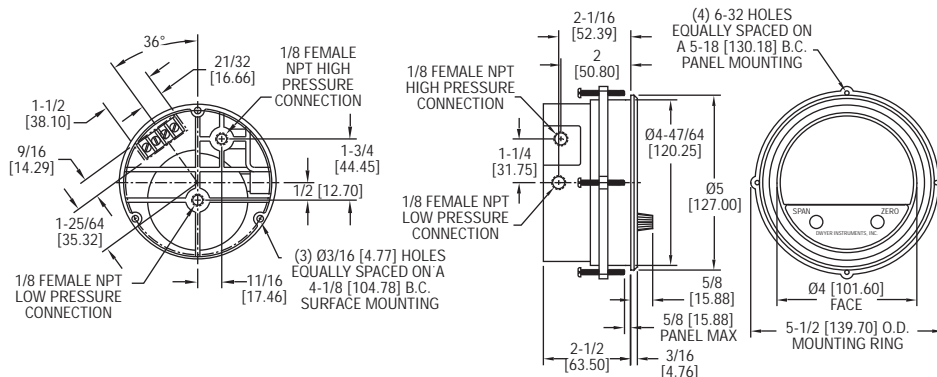

Series 603A Differential Pressure Transmitter

Specifications - Installation and Operating Instructions



The Series 603A Differential Pressure Transmitter converts air or compatible gas pressure into a standard 4-20 mA output signal for pressure ranges from 0-20 in. w.c. up to 30.0 psid (50 Pa up to 206.8 kPa). Each of these models overlap in range so that any range within these pressure limits can be achieved by adjustment of the span and zero controls located on the front of the transmitter. Positive, negative or differential pressures can be measured within an accuracy (see chart) of full span output.

STANDARD ACCESSORIES

- Mounting ring, Snap ring
- (4) 6-32 X 1-1/4" round head machine screws (panel mounting).
- (3) 6-32 X 5/16" round head machine screws (surface mounting).
- (2) Adapters, 3/16" I.D. tubing to 1/8" NPT.
- (2) 1/8" NPT plugs.
- Adjustment key for span and zero.

SPECIFICATIONS

- Service:** Air and non-combustible, compatible gases.
- Wetted Materials:** Consult factory.
- Accuracy:** (See Chart) (Includes linearity, hysteresis and repeatability).
- Stability:** ±1% F.S./yr.
- Temperature Limits:** 0 to 140°F (-17.8 to 60°C).
- Compensated Temperature Limits:** 20 to 120°F (-6.67 to 48.9°C).
- Pressure Limits:** See chart below.
- Thermal Effect:** ±0.025% F.S./°F (0.045% F.S./°C).
- Power Requirements:** 10-35 VDC (2-wire).
- Output Signal:** 4-20 mA.
- Zero and Span Adjustments:** External potentiometers.
- Loop Resistance:** DC; 0-1250 ohms.
- Current Consumption:** DC; 38 mA max.
- Electrical Connections:** 4 screw terminal block.
- Process Connections:** 1/8" female NPT.
- Mounting Orientation:** Diaphragm in vertical position. Consult factory for other position orientations.
- Weight:** 1 lb, 10 oz (737 g).
- Agency Approvals:** CE.

* Optional 3, 4 wire configurations available, contact factory.

Model	Ranges in Inches W.C. (mm)			Maximum Pressure	Electrical Accuracy ± %
	As Stocked	Minimum	Maximum		
603A-1	0-.25 (6.34 mm)	0-0.20 (5.08 mm)	0-0.50 (12.7 mm)	25 psi (1.7 bar)	2
603A-2	0-0.50 (12.7 mm)	0-0.50 (12.7 mm)	0-1.50 (38.1 mm)	25 psi (1.7 bar)	2
603A-3	0-2.0 (50.8 mm)	0-1.5 (38.1 mm)	0-5.0 (127 mm)	2 psi (13.8 kPa)	0.5
603A-4	0-5.0 (127 mm)	0-4.0 (101.6 mm)	0-15 (381 mm)	5 psi (34.5 kPa)	0.5
603A-5	0-25 (634 mm)	0-10 (254 mm)	0-60 (1522 mm)	11 psi (75.8 kPa)	0.5
603A-6	0-100 (2540 mm)	0-50 (1264 mm)	0-250 (6445 mm)	20 psi (1.4 bar)	0.5
603A-11	.25-0-.25 (12.7 mm)			25 psi (1.7 bar)	2
603A-12	1-0-1 (50.8 mm)			2 psi (13.8 kPa)	0.5
603A-13	5-0-5 (254 mm)			5 psi (34.5 kPa)	0.5
603A-14	10-0-10 (508 mm)			11 psi (75.8 kPa)	0.5
	Ranges in PSID (kPa)				
603A-7	0-20 (0-137.9)	0-10 (68.95)	0-30 (206.8)	58 psi (4 bar)	0.5
603A-8	3-15 (20.7-103.4)			30 psi (2.07 bar)	0.5

INSTALLATION

LOCATION: Select a clean, dry location free from shock and vibration where temperature limits will not be exceeded. Distance from the transmitter to the receiver is limited only by total loop resistance. See ELECTRICAL CONNECTIONS. Tubing feeding pressure to the instrument can be practically any length required, but long lengths will increase response time slightly.

POSITION: All standard models are calibrated for use in a vertical mounting position. Higher range models will perform properly at other angles but should be spanned and zeroed in the position in which they will be used. Because of their sensitivity to gravitational forces, models with ranges under 1" w.c. (25.4 mm) must always be mounted vertically.

PRESSURE CONNECTIONS: For installation convenience two sets of 1/8" female NPT pressure ports are supplied. Be sure to seal the unused ports with pipe plugs included.

Positive Pressure - Connect tubing to HIGH PRESSURE port and vent LOW PRESSURE port to atmosphere.

Negative (Vacuum) Pressure - Connect tubing to LOW PRESSURE port and vent HIGH PRESSURE port to atmosphere. (When operating this device in a dusty environment, install an optional A-331 Filter Vent Plug in the vented port to keep interior clean.)

Differential Pressure - Connect tubing from the higher source to HIGH PRESSURE port and from the lower source to LOW PRESSURE port.

MOUNTING: The Series 603A Differential Pressure Transmitter may be either panel (flush) mounted or surface mounted.

Panel Mounting - Cut a 4-13/16" or 122 mm diameter hole in the panel and insert the unit from the front. Slip on the mounting ring with the stepped side facing rear. Next, fit the snap ring into the narrow groove at back edge of bezel. Thread four (6) 3/2 x 1-1/4" mounting screws into tapped holes in mounting ring and set it against snap ring. Tighten screws against rear of panel. See Fig. B.

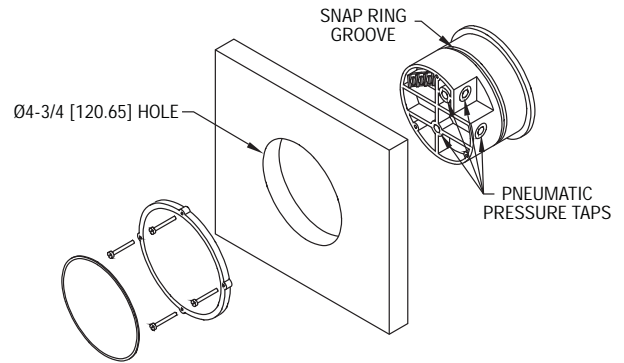

Fig. B

Surface Mounting - Drill (3) 3/16" (4.76 mm) diameter holes for mounting and cut a 9/16" x 1-1/2" (14.3 x 38.1 mm) opening for access to terminal block as indicated in Fig. B. If rear pressure connections are to be used, also provide 1/2" diameter holes as shown in Figs. A and C. Insert 6-32 machine screws from rear of mounting surface, thread into tapped holes on back of transmitter and tighten.

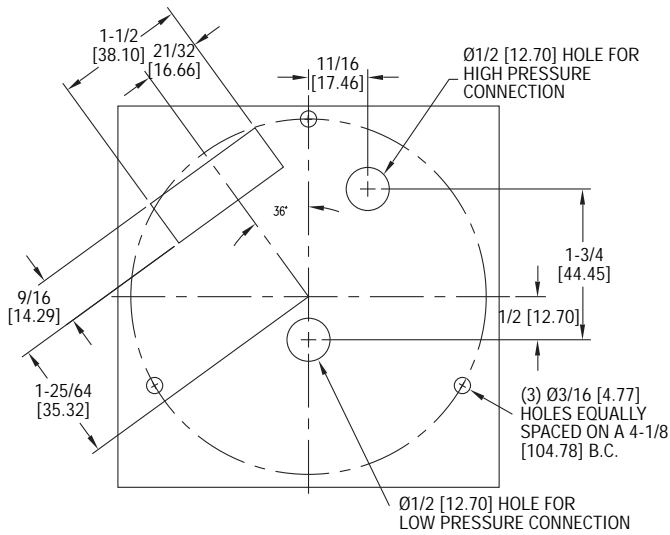

Fig. A

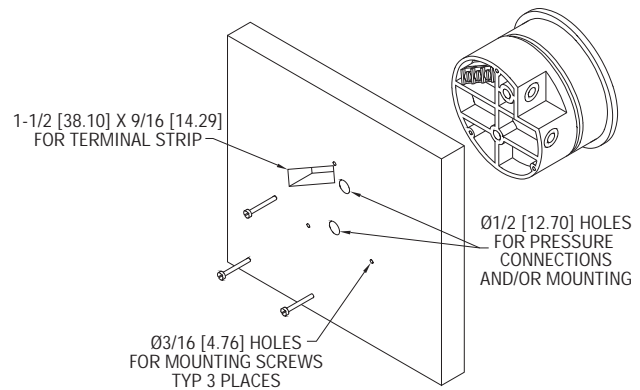

Fig. C

ELECTRICAL CONNECTIONS

CAUTION: Do not exceed specified supply voltage ratings. Permanent damage not covered by warranty will result. This unit is not designed for 120 or 240 volt AC line operation.

All electrical connections for Series 603A Transmitters are made to the four screw terminal strip on the rear of the case. See Fig. D.

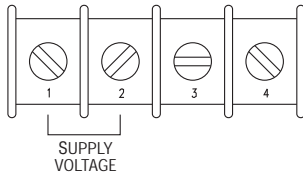

Fig. D

Wire Length - The maximum length of wire connecting transmitter and receiver is a function of wire size and receiver resistance. Wiring should not contribute more than 10% of receiver resistance to total loop resistance. For extremely long runs (over 1000 ft. [305 m]), choose receivers with higher resistances to minimize size and cost of connecting leads. Where wiring length is under 100 ft. (30.48 m), lead wire as small as 22 AWG can be used.

2-Wire Operation - An external power supply delivering 10-35 VDC with minimum current capability of 40 mA DC (per transmitter) must be used to power the control loop. See Fig. E for connection of the power supply, transmitter and receiver. Note the jumper between terminals 3 and 4. The range of appropriate receiver load resistance (R_L) for the DC power supply voltage available is expressed by the formula and graph in Fig. H. Shielded two wire cable is recommended for control loop wiring. If grounding is required use negative side of control loop after receiver. In Fig. E, if power supply lead to terminal 1 is positive, ground should be connected to wiring at right of receiver. Otherwise, in 2 wire operation it is not necessary to observe polarity of control loop connections.

2-WIRE CONNECTION

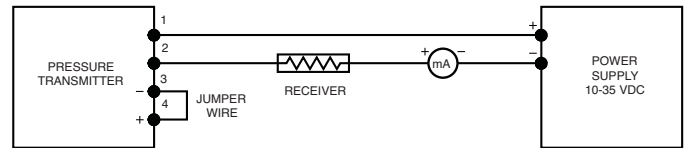

Fig. E

POWER SUPPLY VOLTAGE - VDC

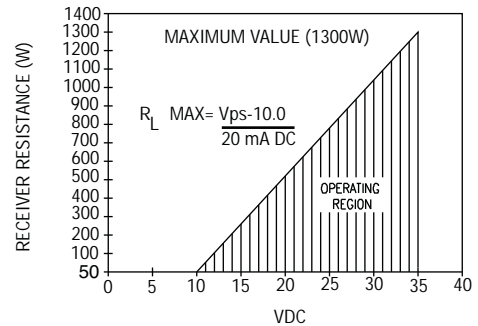

Fig. H

PRESSURE RANGING

Each standard Series 603A Transmitter is factory calibrated to a specific stock range as shown in the Model Number Chart. If unit was specially calibrated it will be marked accordingly. To check calibration or recalibrate to a different range (within limits described in chart), follow the procedure below. For clarification, range is defined as that pressure which applied to the transmitter will produce 20 mA DC of loop current. Zero pressure will produce 4 mA DC.

1. With transmitter connected to its companion receiver and power supply, an accurate milliammeter ranged to approximately 30 mA should be inserted in series with the current loop. A controllable pressure source should be connected to one leg of a tee with remaining legs run to the high pressure port of the transmitter and an accurate reference gage or manometer. Low pressure port must be vented to atmosphere. The transmitter must be calibrated in the same position in which it will be used; vertical is recommended.
2. Apply electrical power to the system and check for proper operation. Slowly apply pressure and observe whether loop current increases above the 4 mA zero pressure value.
3. Apply the full range pressure required and adjust the SPAN control on left for a reading of 20 mA in the current loop.
4. Relieve pressure and adjust the ZERO control on right for a reading of 4 mA in the current loop.
5. ZERO and SPAN controls are slightly interactive so steps 3 and 4 should be repeated until outputs are consistently 4 and 20 mA, respectively.
6. Remove the milliammeter from the current loop, replace cover, make connections to system pressure sources and place unit in service.

MULTIPLE RECEIVER INSTALLATION

An advantage of the standard 4-20 mA DC output signal used in Series 603A Transmitters is the compatibility with a wide range of receivers. Devices such as the A-701 Digital Readout, A-702 Digital Readout with alarms, an analog panel meter, a chart recorder and other process control equipment can be operated simultaneously. It is only necessary that all devices be designed for a standard 4-20 mA input, the proper polarity of input connections be observed and the combined receiver resistances must not exceed the maximum for the current loop. If any receiver indicates a negative or downscale reading, the signal input leads are reversed.

MAINTENANCE

After final installation of the Series 603A Differential Pressure Transmitter, no routine maintenance is necessary. A periodic check of calibration is recommended following the procedure under PRESSURE RANGING. Except for this, these transmitters are not field serviceable and should be returned, freight prepaid, if repair is needed. Be sure to include a clear description of the problem plus any application information available. Contact customer service to receive a return goods authorization number before shipping.