

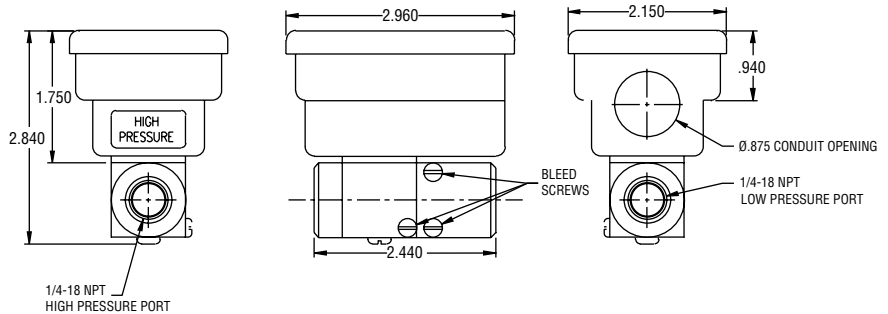

Series 645 Wet/Wet Differential Pressure Transmitter

Specifications - Installation and Operating Instructions



R1-124065-00

GENERAL

The Series 645 Wet/Wet Differential Pressure Transmitter is designed for use with any gas or liquid compatible with 17-4 PH stainless steel, 300 Series stainless steel, Viton and Silicone O-rings and bleed screw seals. Units can accurately measure the differential pressure even when liquid is applied to both ports. The transmitter contains a fast response capacitance sensor and a unique isolation system.

The isolation system transmits the motion of the differential pressure sensing diaphragm from the high line pressure environment to the dry enclosure where it moves one of a pair of capacitance plates proportionally to the diaphragm movement. The variable capacitance is converted to a current proportional to the differential pressure by the capacitance sensing and signal conditioning circuit located in the enclosure. The electronic circuit linearizes output versus pressure, standardizes the output, and compensates thermal effects of the sensor.

INSTALLATION

The Series 645 Differential Pressure Transmitter is supplied with a mounting bracket and two 6-32 \times 3/8 hex head screws. First attach the bracket to mounting location using holes or band clamp notches available on large section of the bracket. Attach the transmitter to the bracket by using the two 6-32 \times 3/8 hex head screws and the two tapped holes located on the underside of the transmitter. See Figure 1 at right.

SPECIFICATIONS

Service: Compatible gases or liquids applied to both pressure and reference ports.

Output: 4 to 20 mA, two-wire.

Supply Voltage: 11 to 30 VDC.

Loop Resistance: 0 to 1000 Ω .

Maximum Line Pressure: 250 psig.

Maximum Overload Pressure: (High side) 1 to 5 psi: 20 \times FS, 10 to 25 psi: 10 \times FS, 50 psi: 5 \times FS, 100 psi: 2.5 \times FS; (Low side) 2-3 \times FS.

Zero and Span: Adjustable, non-interactive, ± 1 mA.

Accuracy: $\pm 0.25\%$ FS.

Temperature Limits: Operating: 0 to 175°F (-22 to 80°C), Storage: -65 to 260°F (-54 to 126°C).

Response Time: 30 to 50 msec.

Thermal Effects: (includes zero and span) $\pm 0.02\%$ FS/°F, 30 to 150°F (-1 to 65°C).

Wetted Parts: 17-4 PH stainless steel, 300 Series stainless steel, Viton and Silicone O-rings and bleed screw seals.

Housing: Stainless steel/Aluminum.

Process Connection: 1/4 - 18 NPT(F).

Electrical Connection: Barrier strip terminal block with conduit enclosure and .875 (22 mm) diameter conduit opening.

Weight: 14.4 oz (0.4 kg).

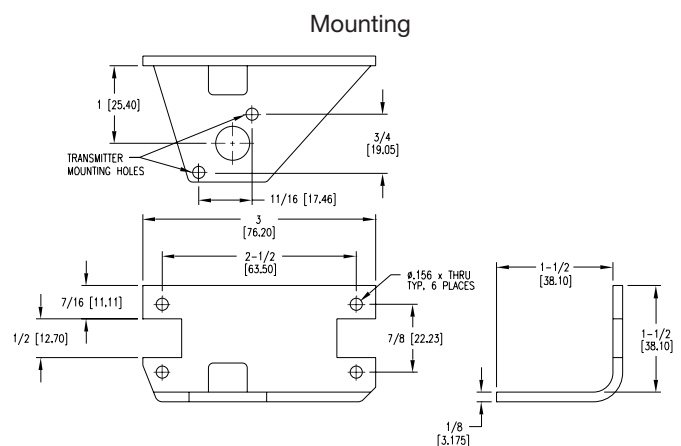

NOTE:

For differential pressure measurements at high line pressure (250 psig max.), it is recommended that the pressure sensor be installed with a valve in each line, plus a shunt valve across the high and low (reference) pressure ports as indicated in Figure 2 below. The high pressure port is labeled with the word "HIGH".

System Set-up

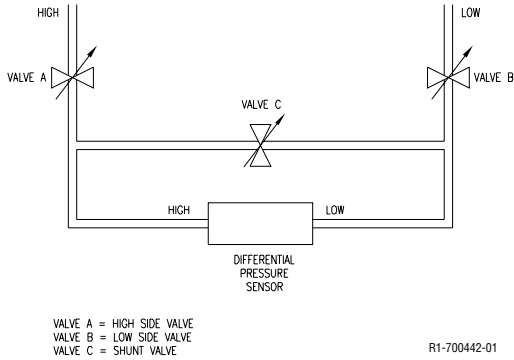

Figure 2

Valve C should be open and Valves A and B closed whenever the system is first being wetted or pressurized. Valves A and B should then be opened slowly to avoid hammering. Valve C can then be closed and the system is operating. When removing the differential pressure sensor, open Valve C first, then close Valves A and B.

Bleeding the Pressure Ports

Three bleed screws are located on the side of the unit (two for low pressure port, one for high pressure port).

Install the transmitter in its intended location and pressurize the ports. Back off the first bleed screw mounted on the flat side of the sensor body (2 turns max.) until liquid begins to flow out. After only bubble-free liquid flows out, retighten the bleed screw. Repeat the same procedure for the second set of bleed screws located on the round section of the low pressure fitting.

Electrical Connections

The Series 645 Wet/Wet Differential Pressure Transmitters are true 2-wire, 4-20 mA current output devices and deliver rated current into any external load of 0 to 800 ohms.

The units are supplied with a 7/8" diameter knockout intended for a 1/2" ID conduit connection. It is suggested that any electrical cable shield be connected to the system's loop circuit ground to improve electrical noise reduction.

When making electrical connections, be sure to observe polarity—units are designed to have current flow in one direction only. The minimum supply voltage is $11 + .02 \times$ (Resistance of receiver plus line). The maximum supply voltage is $30 + .004 \times$ (Resistance of receiver plus line). To access electrical connections, remove cover on top of the unit. See Figure 3 for correct electrical connections.

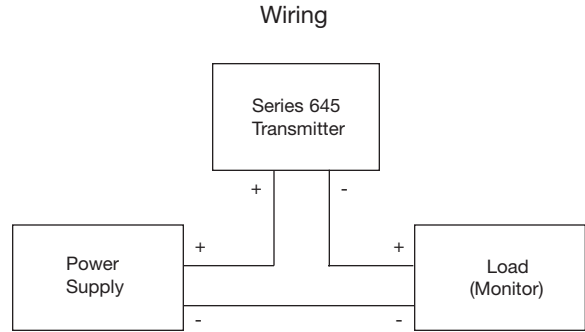

Figure 3

OPERATION

The Series 645 Wet/Wet Differential Pressure Transmitters are carefully calibrated to the specific input pressure range versus current output at the factory. Little or no field calibrating is necessary.

Zero and Span Adjustment

To gain access to the zero and span adjustments, remove the top cover of the transmitter. Loosen the 6-32 seal screws in the plastic terminal block. The zero and span adjustments are located under the plastic terminal block. Be careful not to disconnect any internal wiring. After all adjustments are made, remember to re-install the 6-32 seal screws. The Series 645 transmitters with 4-20 mA output are factory calibrated using a 250 ohm load at 24 VDC. Zero and span adjustments are approximately ± 1 mA, individually.

MAINTENANCE

After final installation of the Series 645 Wet/Wet Differential Pressure Transmitter, no routine maintenance is required. Periodic checks of connections is recommended. Please contact Dwyer Instruments, Inc. before returning unit for repair to review information relative to your application. When returning a product to the factory, carefully package and ship freight prepaid. Be sure to include a complete description of the application and problem and identify any hazardous material used with the product.

