



## Series 1831 Low Differential Pressure Switches

### Specifications - Installation and Operating Instructions



Series 1831 pressure switch.

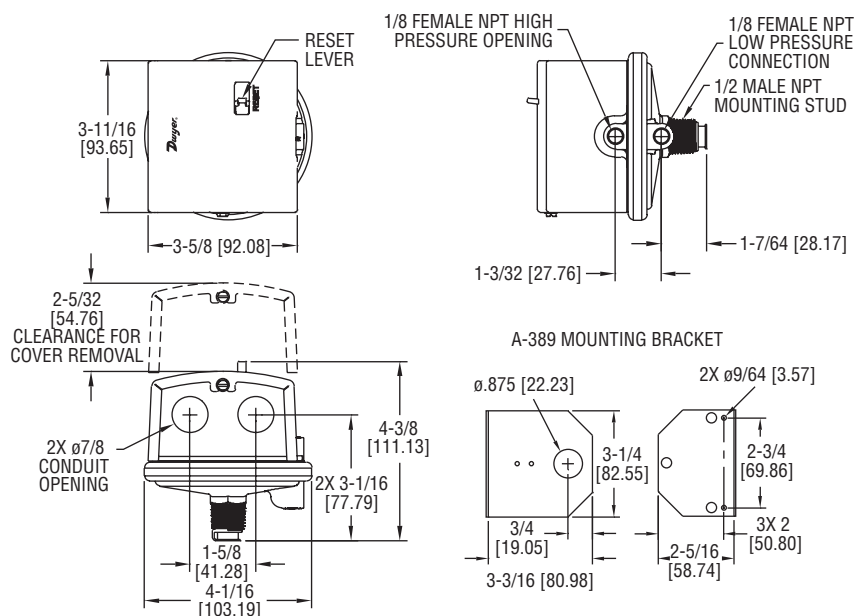

One of our most popular differential pressure switches is now available with a DPDT switch. The 1831 combines small size with 4% set point repeatability. Absolutely no power is required to operate the DPDT switch. Set point adjustment on the switch is easily accessible for modifying the set point. A mounting bracket is included for simplified installation.

#### MANUAL RESET OPERATION - ACTIVATE ON INCREASE

Models with "manual reset" are DPDT configuration and operate as follows: If differential pressure increases above the set-point, the snap switch is actuated or latched so N.O. contacts are closed and N.C. contacts are open. They will remain in that condition even if differential pressure decreases below the set-point until manually deactuated by reset lever.

#### SPECIFICATIONS

**Service:** Air and non-combustible, compatible gases.

**Wetted Materials:** Consult factory.

**Temperature Limits:** -30 to 180°F (-34 to 82.2°C).

**Pressure Limits:** 10 psig (68.95 kPa) continuous, 25 psig (172.4 kPa) surge.

**Switch Type:** 2 SPDT.

**Actuation Time Difference:** 1 millisecond maximum actuation delay between contacts.

**Repeatability:** ±4% max.

**Electrical Rating:** 4A @ 125/250 VAC.

**Electrical Connections:** Screw type terminal block.

**Process Connections:** 1/8" female NPT.

**Mounting Orientation:** Diaphragm in vertical position. Consult factory for other position orientations. Mounting bracket included.

**Set Point Adjustment:** Screw type inside mounting spud.

**Weight:** 1 lb 2 oz (522 g).

## INSTALLATION

1. Select a location free from excessive vibration and where oil or water will not drip upon the switch. See special housings for unusual conditions.
2. **While not required, positioning the pressure connections down is recommended.** Mount the switch with the diaphragm in a vertical plane. Switch must be recalibrated for each change in operating position.

### Mounting when using optional A-389 Mounting Bracket

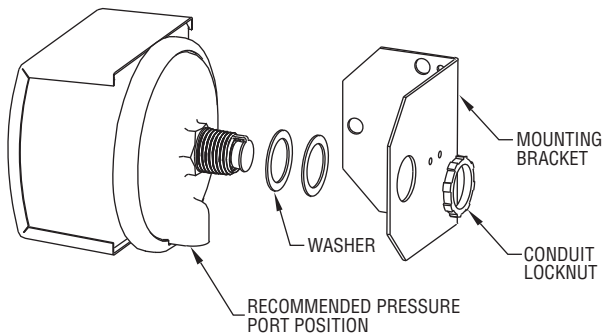

3. Connect switch to source of pressure differential. Metal tubing with 1/4" O.D. is recommended but any tubing system which will not restrict the air flow is satisfactory. Note that the low pressure connection may be made to the 1/2" spud at the back of the switch if desired. If so connected, drill 1/16" diameter holes in the Spring Retainer flange and the head of Adjustment Screw to provide opening to the switch interior and plug the other low pressure connection.
4. Electrical connections to the snap switches are provided by means of terminal block marked "common", "norm open", and "norm closed". The normally open contacts close and the normally closed contacts open when pressure increases beyond the set point. For failsafe applications, it is recommended to use N.C. contact wiring. Use 14-30 AWG copper wire rated 194°F (90°C) min.
5. Switch loads should not exceed the maximum specified current rating of 4 amps resistive on standard models. Switch capabilities decrease with high load inductance or rapid cycle rates. Whenever an application involves one or more of these factors, the user may find it desirable to limit the switched current to 3 amps or less in the interest of prolonged switch life.

## Wiring Terminals

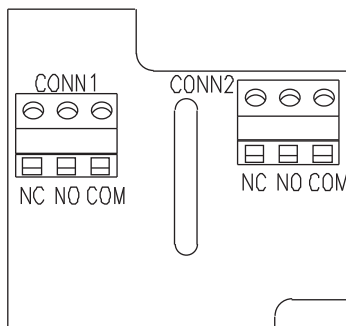

## ADJUSTMENT

1. If the switch has been factory preset, check the set-point before placing in service to assure it has not shifted in transit.
2. If switching has not been preset or it is desired to change the point, observe the following procedure:
  - a. To adjust the set point turn the slotted Adjustment Screw clockwise to increase the set point and counterclockwise to decrease the set point.
  - b. The following is a recommended procedure for calibrating or checking calibration: Use a "T" assembly with three rubber tubing leads, all as short as possible and the entire assembly offering minimum flow restriction. Run one lead to the pressure switch, another to a manometer of known accuracy and appropriate range, and apply pressure through the third tube. Make final approach to the set point slowly. Note the manometer and pressure switch will have different response characteristics due to different internal volumes, lengths of tubing, oil drainage, etc. Be certain switch is checked in position it will assume in use, i.e. vertical, horizontal, etc.

## MAINTENANCE

Upon final installation of the Series 1831 Low DPDT Differential Pressure Switch, no routine maintenance is required. A periodic check of product performance is recommended. Check by applying pressure to activate the switches. Ensure the reset level properly resets both switches after the set point threshold has been withdrawn. The Series 1831 is not field serviceable and should be returned if repair is needed (field repair should not be attempted and may void warranty). Be sure to include a brief description of the problem plus any relevant application notes. Contact customer service to receive a return goods authorization number before shipping.