

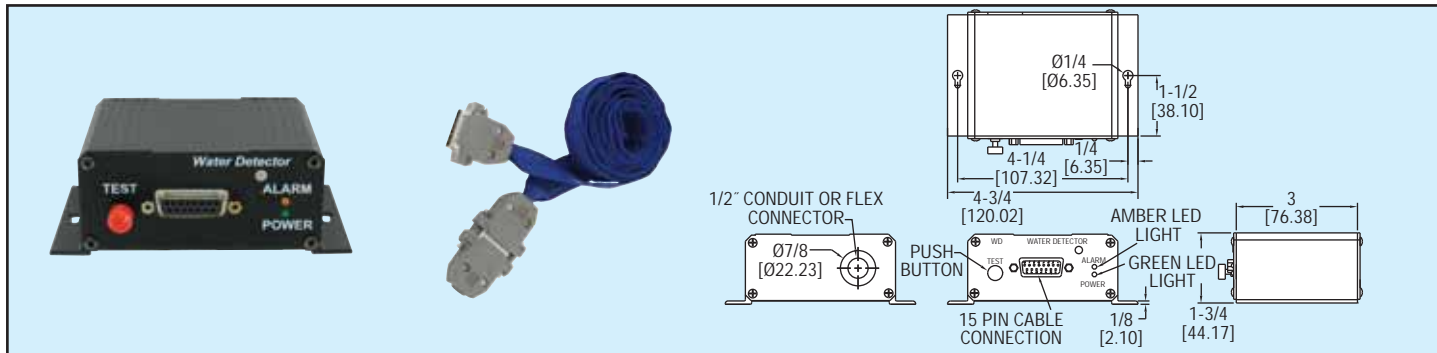

Model
WD

Water Detector and Sensor Tape

Detects Low Levels Of Conductive Liquids



The small and discreet Model WD Water Detector is designed for dependable detection of low levels of conductive liquids. The module features a sturdy and reliable aluminum enclosure and is powered by 24 VAC or 24 to 30 VDC. Water sensing tape attaches to module and if any liquid comes in contact with the tape the resistance is changed and the alarm will be triggered. The tape is hydrophobic so it does not absorb any of the liquid it is detecting which makes for a faster drying time and faster return to service after a water leak.

The sensing tape is 1" wide and can be bought in lengths of 5, 10, 15 and 25 feet. Multiple tapes can be connected together to extend the coverage area which makes it ideal for domestic as well as commercial applications. Features include power and alarm LED's, alarm test switch, continuous tape integrity self check and extendable tape sensor.

SPECIFICATIONS

Service: Conductive liquid.

Switch Type: DPDT.

Electrical Rating: 1A @ 24 VAC/VDC.

Power Requirements: 24 VAC, 24 to 30 VDC.

Power Consumption: 35 mA maximum.

Electrical Connections: Screw terminals.

Conduit Connections: Hole for 1/2" conduit.

Enclosure: Extruded aluminum.

Sensor Tape: 1" (25.4 mm) wide and 5, 10, 15 or 25 feet long.

Weight: 8 oz (.23 kg).

Model	Description
WD	Water Module
TP05	5' (1.52 m) Tape
TP10	10' (3.05 m) Tape
TP15	15' (4.57 m) Tape
TP25	25' (7.62 m) Tape