

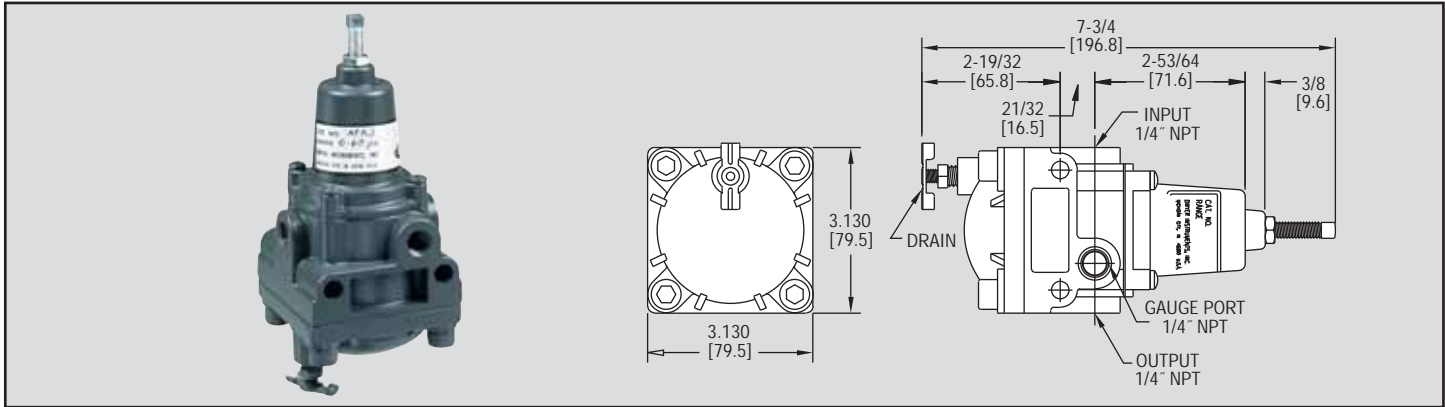

Series
AFR

Air Filter Regulator



Series AFR Air Filter Regulator provides clean air pressure to pneumatic controllers, valve positioners, air cylinders and other equipment. Self-relieving regulator is equipped with a 40 micron filter housed in a dripwell with gage port.

Model	Range
AFR1	0 to 10 psi (0 to 65 kPa)
AFR2	0 to 30 psi (0 to 200 kPa)
AFR3	0 to 60 psi (0 to 400 kPa)
AFR4	0 to 120 psi (0 to 800 kPa)

AFR-BRKT, Mounting Bracket

SPECIFICATIONS

Service: Air only.

Wetted Materials: Body: Aluminum alloy, irridite, and lock epoxy finish; Filter: phenolic impregnated cellulose; diaphragm and valve seat plug: nitrile elastomer.

Max. Supply Pressure: 250 psig (1700 kPa).

Temperature Limits: 0 to 160°F (-18 to 71°C).

Sensitivity: 1" (2.5 cm) of water.

Consumption: <6 SCFH (0.17 m³/hr).

Flow Capacity: 20 SCFM (33 m³/hr) @ 100 psig (700 kPa) supply.

Exhaust Capacity: 0.1 SCFM (0.17 m³/hr) with downstream pressure 5 psig (35 kPa) above set point.

Process Connection: 1/4" female NPT.

Weight: 1.6 lb (725 g).