

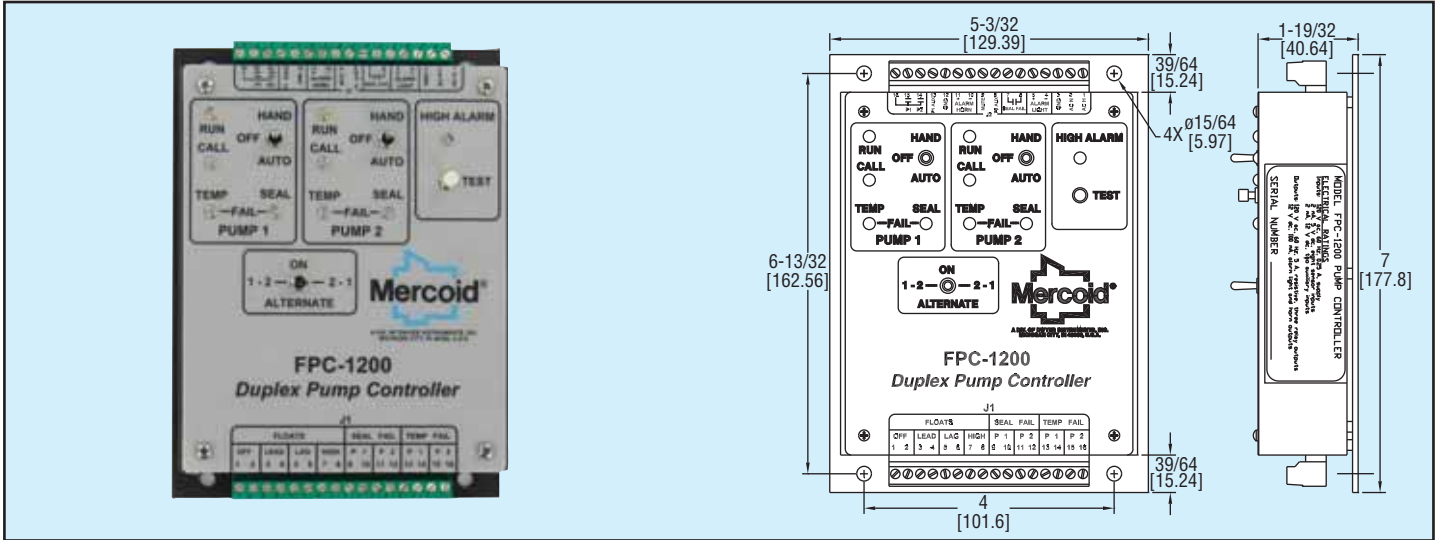

Model
FPC-1200

Duplex Pump Controller

Full-Featured, Low-Cost



Duplex Pump Controller Model FPC-1200 is a float switch based duplex pump controller intended primarily for wastewater lift stations and other pump down applications. The FPC-1200 connects to four float switches to measure the tank level and has relay outputs to control two pumps and a seal-fail alarm. It includes sensor inputs for the seal failure and temperature failure devices on most submersible pumps. In the event of a seal failure, the Seal Fail indicator and the Seal Fail output relay are energized, and the corresponding pump is demoted to lag position. In the event of a temperature failure, the Temp Fail indicator is energized and the corresponding pump is disabled until the temperature failure condition no longer exists. Two 12V driver outputs are included for the High Alarm horn and light. If the High float is activated (closed), the High Alarm driver outputs are activated and the High Alarm indicator will flash on and off. A Mute input and High Alarm Test pushbutton allow the alarm to be silenced and tested during operation. The controller has built-in HOA (hand-off-automatic) switches and each pump has Call and Run indicators. The Call indicators are energized when the controller activates each load pump and the Run indicators are energized by feedback from each motor starter auxiliary contact. The HOA switches allow each pump to be energized manually, disabled, or energized automatically by the float inputs. A lead pump selector switch permits either pump to be selected as lead pump or alternation can be selected causing either pump to operate as lead. The FPC-1200 uses removable terminal strips to make replacement in the field quick and easy. With the addition of an enclosure, circuit breakers, and motor starters, the FPC-1200 makes a complete low cost lift station controller.

SPECIFICATIONS

Inputs:

Floats:

- Open circuit voltage: 5 VDC;
- Short circuit current: 2 mA maximum.

Auxiliary motor starter contacts:

- Open circuit voltage: 12 VDC;
- Short circuit current: 2 mA maximum.

Temperature and seal failure:

- Open circuit voltage: 5 VDC;
- Short circuit current: 2 mA maximum.

Mute:

- Open circuit voltage: 5 VDC;
- Short circuit current: 2 mA maximum.

Output Type: (2) Form A SPST contacts for pump output, (1) Form A SPST contact for seal-fail alarm, (2) 12 VDC driver outputs for High Alarm horn and light.

Output Ratings:

- Form A SPST: 5 A @ 120 VAC;
- 12 VDC driver: 100 mA @ 12 VDC.

Control Type: On/off pump out (down).

Power Requirements: 120 VAC ± 15%, 50 to 70 Hz.

Power Consumption: .25 A @ 120 VAC.

Temperature Limits: -4 to 140°F (-20 to 60°C).

Seal Failure (Moisture Sensor): Trip point: 50,000 Ohms.

Weight: 1 lb 4 oz. (454 g).

Agency Approvals: UL.

Model FPC-1200, Duplex Pump Controller