

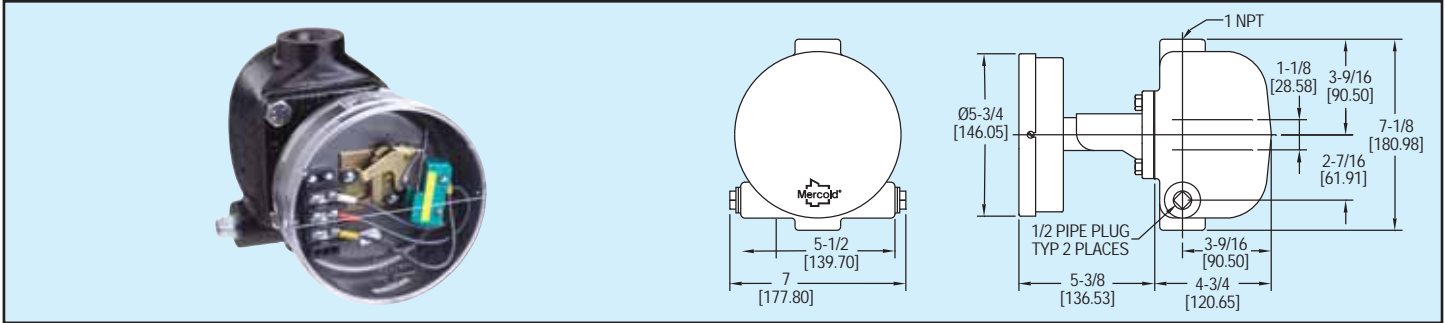

Series
123

Boiler Water Level Control

Heavy Duty, Cast Iron Chamber



A special snap action mechanism eliminates frequent operation due to surging water level. Visible operation adds convenience in servicing. Stainless steel trim and hand reset are available if required. Options include DPDT switch, two stage, and weatherproof housing.

APPLICATIONS

- Boiler Low Water Cut-Off
- Boiler Feed-Water Control
- Condensate Tanks
- Deaerators

Model	Switch Type
123-153	SPDT Mercury
123-7000-153	SPDT Snap

SPECIFICATIONS

Service: Compatible liquids. Cast iron is not for use with lethal or flammable substances either liquid or gaseous.

Wetted Materials: Body: Cast iron. Float and Trim: 304 SS. Packing Gland: Brass. Packing: Carbon. Body Gasket: Carbon.

Temperature Limit: 365°F (185°C).

Pressure Limit: 150 psig (10.34 bar).

Enclosure Rating: General Purpose. Optional weatherproof.

Switch Type: SPDT snap switch or mercury switch. Optional DPDT or two stage.

Electrical Rating: Snap Switch: 15A @ 120/240/480 VAC, 0.5A @ 120 VDC resistive, 0.25A @ 240 VDC resistive. Mercury Switch: 4A @ 120 VAC/DC, 2A @ 240 VAC/DC.

Electrical Connections: Screw terminal.

Conduit Connection: 7/8" (22.23 mm) hole for 1/2" (12.7 mm) conduit.

Process Connections: 1" female NPT.

Mounting Orientation: Vertical.

Weight: 20 lb (9.1 kg).

Agency Approvals: UL and CSA. (Snap switch is not rated).

Deadband: Approximately 1-1/2" (38.1 mm).

Specific Gravity: 0.88 minimum.

Options: Manual Reset.