

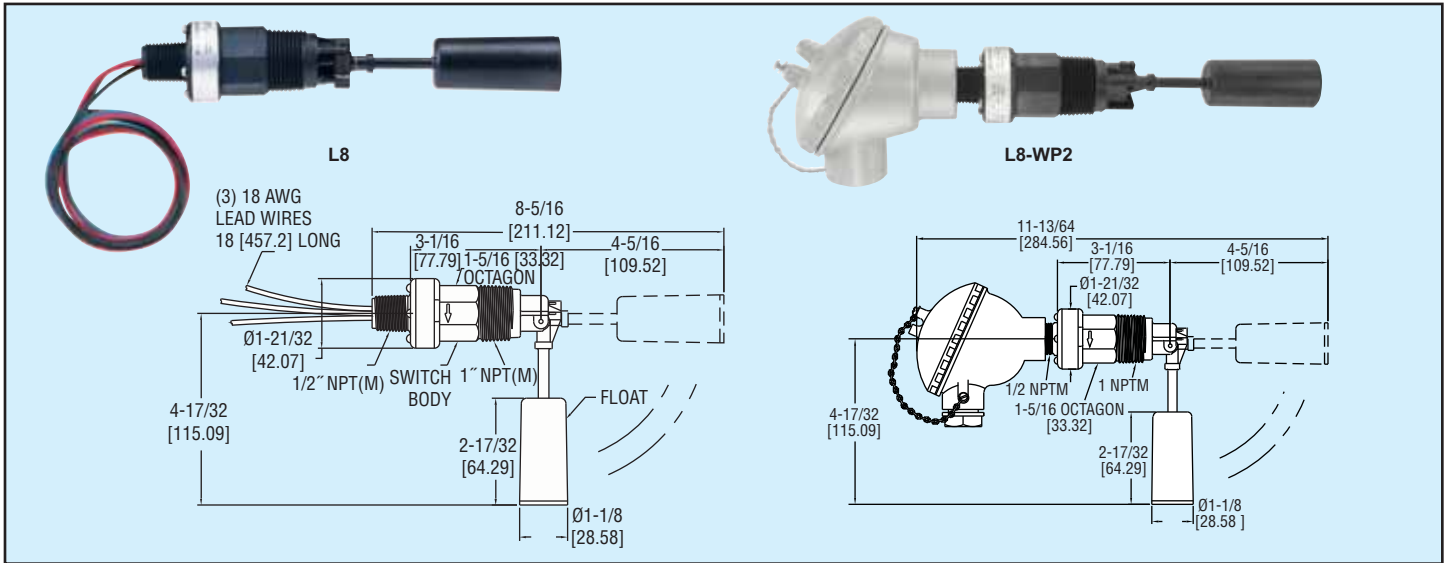

Series  
L8

# FLOTECT® Liquid Level Switch

Low Cost, Leak Proof Body, Excellent Chemical Resistance



**Model L8 Flotect® Liquid Level Switch** features a leak proof body and float constructed from tough, durable polyphenylene sulfide which has excellent chemical resistance. Because the liquid level snap switch is magnetically actuated, there is no direct mechanical linkage to leak or fail, assuring longer life and decreased maintenance costs. This inexpensive unit is ideal for liquid level alarm, indication or control. Installation is quick and easy – simply install in a horizontal position with the index arrow pointing down. The L8 Flotect® Liquid Level Switch is UL recognized as an industrial motor controller per UL standard 508, suitable for mounting in a protected environment. This lightweight switch can be used in numerous chemical process, industrial systems and similar applications where process conditions are compatible with polyphenylene sulfide, ceramic 8 and 316 SS. This liquid level switch provides accurate setpoint control of liquids with specific gravities as low as 0.6. This compact and reliable control is designed to handle temperatures up to 212°F (100°C) and pressures to 150 psig (10 bar).

## APPLICATIONS

The Model L8 Flotect® Liquid Level Switch is ideal for predetermined liquid levels in tanks through pump control or solenoid valve control. It provides excellent liquid level alarm or indication when combined with the Series AN14 Indicating Annunciator.

- Environmental control
- Waste water
- Scrubber systems
- Holding tanks
- Cooling towers
- Chemical/Petroleum processing
- Plating and washing tanks
- Sewage treatment
- Car washes
- Remediation systems

## SPECIFICATIONS

**Service:** Compatible liquids.

### Wetted Materials:

- Float and Body: Polyphenylene Sulfide (PPS).
- Pin and Spring: 316 SS or Inconel®.
- Magnet: Ceramic 8.

**Temperature Limit:** 212°F (100°C).

**Pressure Limit:** 150 psig (10.34 bar).

**Enclosure Rating:** General purpose. WP/WP2 option is weatherproof.

**Switch Type:** SPDT snap switch. MV option is a SPDT gold contact snap switch.

**Electrical Rating:** 5A @ 125/250 VAC, 5A resistive, 3A inductive @ 30 VDC. MV option: 1A @ 125 VAC, 1A resistive, 0.5A inductive @ 30 VDC.

**Electrical Connections:** 18 AWG, 18" (460 mm) long.

**Conduit Connection:** 1/2" male NPT, 1/2" female NPT on WP and WP2.

**Process Connection:** 1" male NPT.

**Mounting Orientation:** Horizontal with index arrow pointing down.

**Weight:** 5 oz (0.142 kg).

**Agency Approvals:** CE, UL 508 for US and Canada.

**Specific Gravity:** 0.6 minimum.

## Series L8, Level Switch

### OPTIONS

**Gold Plated Contacts**, for dry circuits. Rated 1A @ 125 VAC; 1A resistive, 0.5A inductive @ 30 VDC. To order add suffix -MV.

Example: **L8-MV**

**Inconel® Alloy Option.** Inconel® Alloy replaces standard 316 SS wetted parts. Wetted parts are Inconel® Alloy, ceramic 8, and Polyphenylene Sulfide. To order add suffix -INC.

Example: **L8-INC**

**Weatherproof Enclosure.** Optional housing is phenylpolioxide and provides weatherproof protection for electrical wiring.

To order add suffix -WP. (Not UL approved)

Example: **L8-WP**

**Weatherproof Enclosure.** Optional housing is aluminum and provides weatherproof protection for electrical wiring. To order add suffix -WP2. (Not UL approved)

Example: **L8-WP2**

Inconel® is a registered trademark of Huntington Alloys Corporation