



Series
1800

Low Differential Pressure Switches for General Industrial Service

Set Points from 0.07" to 85" w.c. Repetitive Accuracy within 2%



Pressure

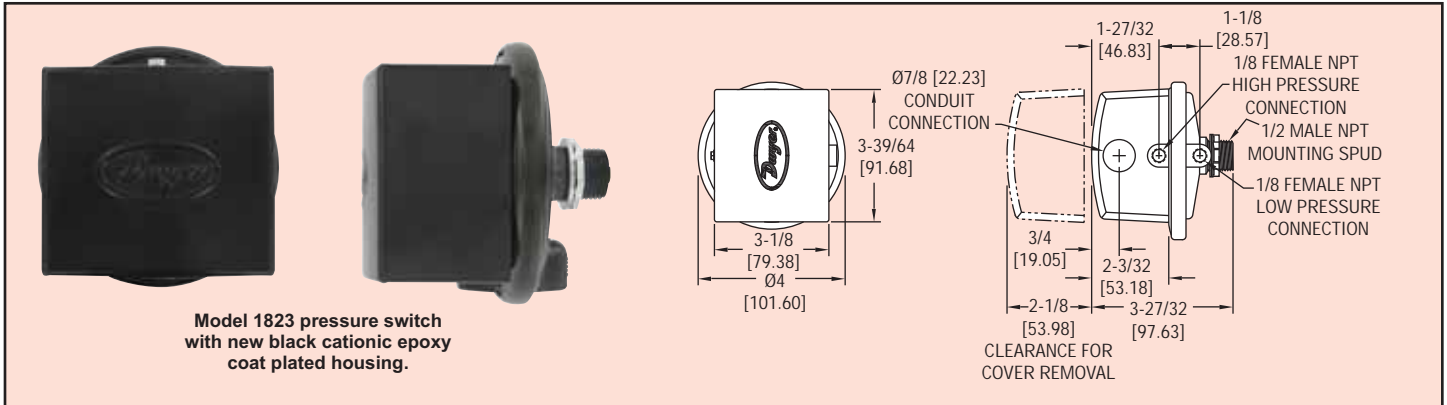

Essential for industrial environments, the Series 1800 combines small size and low price with 2% repeatability for enough accuracy for all but the most demanding applications. Set point adjustment inside the mounting stud permits mounting switch on one side of a wall or panel with adjustment easily accessible on the opposite side. UL and CSA listed, FM approved.

CAUTION: For use only with air or compatible gases.

Series 1823 Switches Operating Ranges & Deadbands

Model	Operating Range, Inches W.C.	Approximate Dead Band	
		At Min. Set Point	At Max. Set Point
1823-00	0.07 to 0.22	0.05	0.05
1823-0	0.15 to 0.5	0.06	0.06
1823-1	0.3 to 1.0	0.08	0.08
1823-2	0.5 to 2.0	0.10	0.12
1823-5	1.5 to 5.0	0.14	0.28
1823-10	2.0 to 10	0.18	0.45
1823-20	3 to 22	0.35	0.70
1823-40	5 to 44	0.56	1.10
1823-80	9 to 85	1.30	3.0

MIL Environmental Construction — Unlisted Model 1820 can be furnished with a special sealed snap switch for protection against high humidity, fungus and/or military applications. Similar to Model 1823 except dead band is slightly greater and some lower setpoints may not be possible. To order, add suffix -MIL. Example: 1820-2-MIL.

No. A-389 Mounting Bracket is 16 ga. steel, zinc plated and dichromate dipped for corrosion resistance. Provides rugged, permanent mounting and speeds installation.

SPECIFICATIONS

Service: Air and non-combustible, compatible gases.
Wetted Materials: Consult factory.
Temperature Limits: -30 to 180°F (-34 to 82.2°C). 1823-00, -20 to 180°F (-28.9 to 82.2°C).
Pressure Limits: 10 psig (68.95 kPa) continuous, 25 psig (172.4 kPa) surge.
Switch Type: Single-pole double-throw (SPDT).
Repeatability: ±2%.
Electrical Rating: 15 A @ 120-480 VAC, 60 Hz. Resistive 1/8 HP @ 125 VAC, 1/4 HP @ 250 VAC, 60 Hz. Derate to 10 A for operation at high cycle rates.

Electrical Connections: 3 screw type, common, normally open and normally closed.

Process Connections: 1/8" female NPT.

Mounting Orientation: Diaphragm in vertical position. Consult factory for other position orientations.

Set Point Adjustment: Screw type inside mounting stud.

Weight: 1 lb, 5 oz (595 g).

Agency Approvals: CE, UL, CSA and FM approved. Optional-EXPL Explosion-proof enclosure does not possess any agency approvals.

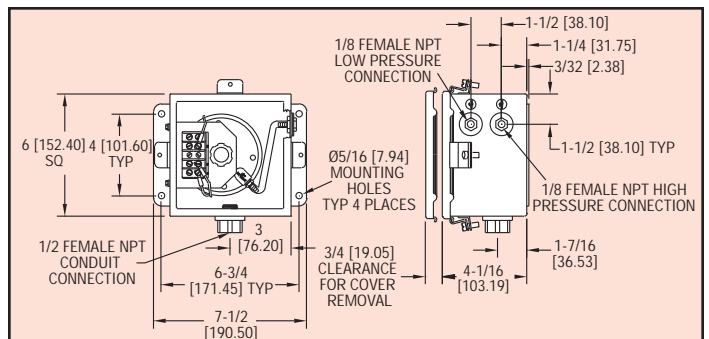

Weatherproof Housing:

16 ga. steel enclosure with gasketed cover (NEMA 4, IP66) for wet or oily conditions. Withstands 200 hour salt spray test. Wt. 5-1/2 lbs. (2.5 kg). Switch must be factory installed. Change 1823 base number to 1824 and add -WP suffix. Example: 1824-1-WP

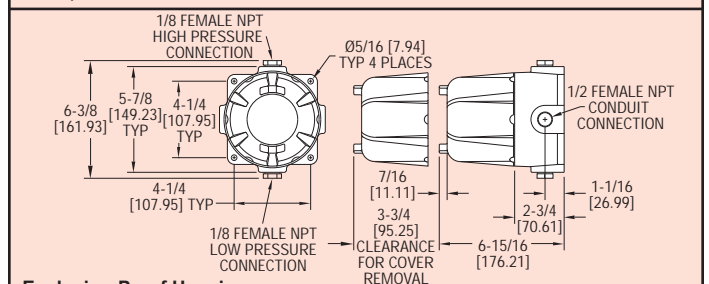

Explosion-Proof Housing:

Cast iron base with aluminum cover. Rated Class I, Div. 1 & 2, Group D; Class II, Div. 1 & 2, Groups E, F, G; Class III and NEMA 7 CD, 9 EFG. Wt. 7-1/2 lbs. (3.4kg). Switch must be factory installed. Change base number to 1824 and add -EXPL suffix.

Example: 1824-1-EXPL