

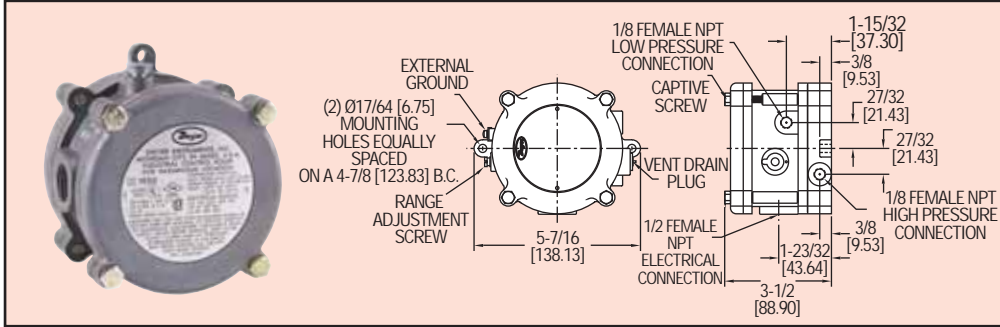

Series  
1950

# Explosion-proof Differential Pressure Switches

Compact, Low Cost, Explosion-proof and Weatherproof



**Model 1950 Explosion-Proof Differential Pressure Switch** combines the best features of the popular Dwyer® Series 1900 Pressure Switch with an integral explosion-proof and weatherproof housing, making it an exceptional value for either application. It is CE, UL and CSA listed, FM approved for use in Class I, Div 1, Groups C and D, Class II Groups E, F, and G and Class III hazardous atmospheres (NEMA 7 & 9), Raintight NEMA 3 (IP54). Weatherproof features include a drain plug and O-ring seal in cover. Electrical connections are easily made by removing front cover. For convenience the set point adjustment screw is located on the outside of the housing. Twelve models offer set points from .03 to 20" w.c. (7.5 to 5 kPa) and from .5 to 50 psi (0.035 to 3.5 bar). The unit is very light and compact – about half the weight and bulk of other explosion-proof or weather-proof switches with separate enclosures.

## Series 1950 Switches - Operating Ranges and Dead Bands

Model	Range, Inches W.C.	Approximate Dead Band at	
		Min. Set Point	Max. Set Point
1950-02-2S	.03 to .10	.025	.05
1950-00-2F	.07 to .15	.04	.05
1950-0-2F	.15 to .50	.10	.15
1950-1-2F	.4 to 1.6	.15	.20
1950-5-2F	1.4 to 5.5	.30	.40
1950-10-2F	3 to 11	.40	.50
1950-20-2F	4 to 20	.40	.60

## SPECIFICATIONS

**Service:** Air and non-combustible, compatible gases.

**Wetted Materials:** Consult factory.

**Temperature Limits:** -40 to 140°F (-40 to 60°C); 0 to 140°F (-17.8 to 60°C) for 1950P-8, 15, 25, and 50. -30 to 130°F (-34.4 to 54.4°C) for 1950-02.

### Pressure Limits:

Continuous: 1950's - 45" w.c. (0.11 bar); 1950P's - 35 psi (2.41 bar); 1950P-50 only - 70 psi (4.83 bar).

Surge: 1950's - 10 psi (0.69 bar), 1950P's - 50 psi (3.45 bar), 1950P-50 only - 90 psi (6.21 bar).

**Enclosure Rating:** NEMA 3 (IP54), NEMA 7 & 9.

**Switch Type:** Single-pole double-throw (SPDT).

**Electrical Rating:** 15 A @ 125, 250, 480 VAC, 60 Hz. Resistive 1/8 HP @ 125 VAC, 1/4 HP @ 250 VAC, 60 Hz.

**Electrical Connections:** 3 screw type, common, normally open and normally closed.

**Process Connections:** 1/8" female NPT.

**Mounting Orientation:** Diaphragm in vertical position. Consult factory for other position orientations.

**Set Point Adjustment:** Screw type on top of housing.

**Weight:** 3.25 lb (1.5 kg); 1950-02 model, 4.4 lb (2 kg).

**Agency Approvals:** CE, UL, CSA, FM.

Model*	Range, PSID	Approximate Dead Band at	
		Min. Set Point	Max. Set Point
1950P-2-2F	0.5 to 2	.3	.3
1950P-8-2F	1.5 to 8	1.0	1.0
1950P-15-2F	3 to 15	.9	.9
1950P-25-2F	4 to 25	.7	.7
1950P-50-2F	15 to 50	1.0	1.5

**CAUTION:** For use only with air or compatible gases. Applications with hazardous atmospheres and a single positive pressure may require special venting. \*P=PSID range models