



Series
MC

Multi-Cal Pressure Calibrator



Interchangeable Ranges, $\pm 0.05\%$ Accuracy, Datalogging Capability, NIST Traceable

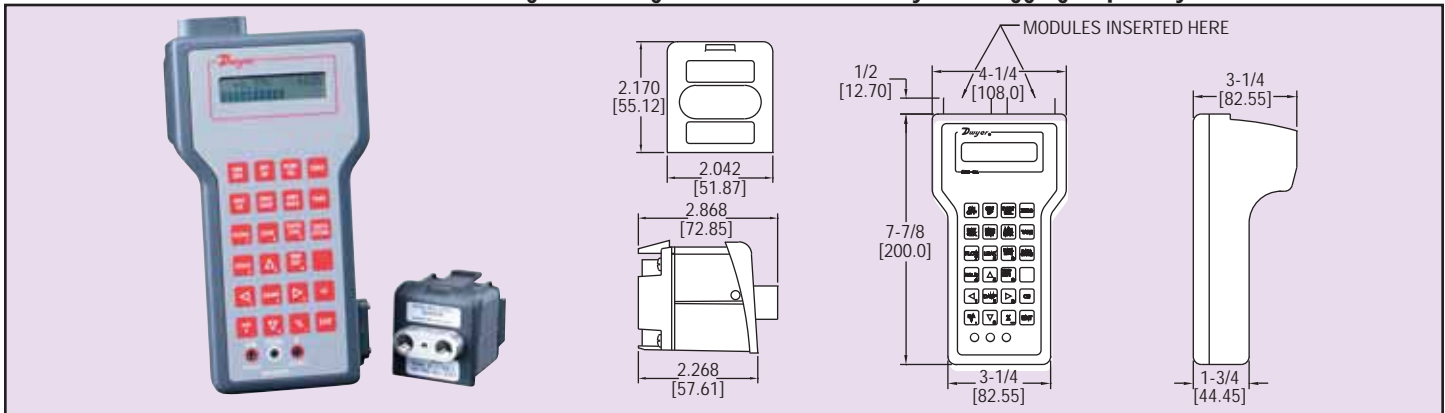

Series MC Portable Multi-Cal Pressure Calibrator performs a wide variety of simple and complex pressure based measurement, test, and calibration operations. Modular sensor design allows user to select pressure measurement range for application flexibility. Calibrator can accommodate up to two interchangeable pressure modules (sold separately below) in any combination of range or accuracy.

Simultaneously display two separate measurements on the two line, alphanumeric display. Readings can be displayed in a choice of 12 preprogrammed engineering units or any single user-defined unit. Calibrator features min/max recall, hi/lo alarm, percentage of full scale pressure readings, mA/voltage measurement, leak rate and pressure decay measurement, switch testing capabilities, including trip point and dead band, and velocity/volume flow rates.

Quickly document calibration procedures using the data logging feature which stores up to 384 sets of pressure and time/date stamped measurements. Easily upload stored data to an IBM compatible computer via the RS232 port. Calibrators and modules include certification to NIST traceability—ideal as a secondary standard for calibrating pressure equipment.

Multi-Cal Pressure Calibrator includes utility software, test leads, protection module, adjustable hand strap, AC adapter, two 9V batteries, instruction manual, and hard carrying case.

Model MC2K, Handheld Calibrator

ACCESSORY

CP40, Serial Printer

Multi-Cal Pressure Modules are interchangeable and available in a wide selection of pressure ranges and accuracies. Handheld calibrator accepts up to two pressure modules. Modules include NIST calibration certification.

Model	Range
MC1000	0.25" H ₂ O Differential Pressure, ± 0.07
MC1001	0.50" H ₂ O Differential Pressure, ± 0.07
MC1004	5.00" H ₂ O Differential Pressure, ± 0.06
MC1006	25" H ₂ O Differential Pressure, ± 0.06
MC2010	5.0 psig Gauge Pressure, ± 0.05
MC2012	15.0 psig Gauge Pressure, ± 0.05
MC2016	100.0 psig Gage Pressure, ± 0.05

OPTIONS

Consult factory for other pressure ranges and accuracies. FM approved models are also available.

SPECIFICATIONS

Service: Clean, dry, nonconductive, noncorrosive gases.

Accuracy: Differential Pressure Modules: $\pm 0.06\%$ FS, Gauge Pressure Modules: $\pm 0.05\%$ FS, Voltage Input: $\pm 0.025\%$ FS @ 0/10 VDC, $\pm 0.10\%$ FS @ 0/30 VDC, Current Input: $\pm 0.03\%$ FS @ 0/20 mA, $\pm 0.05\%$ FS @ 0/50 mA.

Sensitivity: $\pm 0.002\%$ of span with dampening 1 part in 50,000 (max).

Repeatability: Ranges $\leq 0/2$ psi: $\pm 0.05\%$ of span, Ranges $\geq 0/5$ psi: $\pm 0.02\%$ of span.

Output: RS232 serial interface, 9-pin.

Alarm Output: SPST form C 110 VDC, 120 VDC (max.), 1 A (max), 30 W, 62.5 VA (resistive).

Display: Alphanumeric LCD, 0.37" (9.5 mm) height per line, 2 lines, 16 characters/line.

Display Update: 100 msec.

Ambient Operating Temperature: 32 to 120°F (0 to 49°C).

Storage Temperature: -4 to 158°F (-20 to 70°C).

Process Connection: 1/8" female NPT.

Electrical Connections: Miniature recessed banana jacks.

Power Requirements: Internal: two 9 VDC alkaline batteries, External: AC adapter 9 VDC, 500 mA.

Battery Life: 30 hours (approximate).

Engineering Units: inH₂O, psi, inHg, kPa, mbar, cmH₂O, mmHg, and user-defined.

Overpressure: Differential Pressure Modules: 50 psi positive direction, 15 psi negative direction, Gage Pressure Modules: 2x range (0/5 psi to 0/1000 psi).

Temperature Compensation: 20 to 120°F (-7 to 49°C).

Temperature Error: Maximum of $\pm 0.004\%$ of span per °F over compensated range for zero and span.

Temperature Effect Electrical Measurement: $\pm 0.001\%$ of span per °F over compensated range.

Dampening: (Measurement averaging) programmable from 0 to 16 consecutive readings.

Baud Rate: 300, 1200, 2400, or 9600, selectable.

Housing Material: ABS plastic.

Weight: Calibrator: 2.2 lb (1.3 kg), Pressure Module: 0.5 lb (0.3 kg).

Agency Approvals: CE.

APPLICATIONS

Pressure measurement for clean room control, filter performance monitoring, HVAC testing and setup, draft measurement, airflow measurement control, differential pressure measurement in laminar flowhoods, paint booths, industrial ovens and fume hoods. Use as a secondary standard for calibrating pressure equipment.