

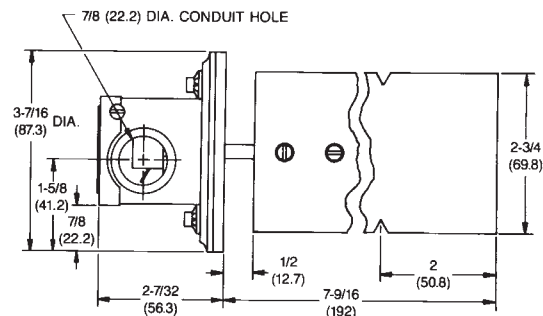

Model 530 Air Flow Switch

Specifications - Installation and Operating Instructions

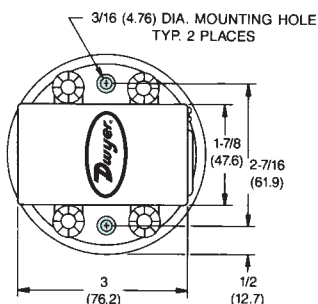

The Model 530 Air Flow Switch provides excellent sensitivity and reliability at a very reasonable price. Quality features include rugged die cast zinc body, stainless steel vane, silicone rubber gasket and SPDT snap switch. Unit is easily field adjustable from 400-1600 FPM. Mounting is fast and simple, requiring only two screws. Vane fits 6 in. or larger ducts. UL approved. To order, specify Dwyer Instruments, Inc. Model 530 Air Flow Switch.

SPECIFICATIONS

Service: Air and non-combustible gas flow.

Wetted Materials: Contact factory.

Vane: Stainless Steel.

Temperature Limit: 180°F (82°C).

Switch Type: SPDT.

Electrical Rating: 125 VAC - 9.8 amp full load 58.8 amp locked rotor. 250 VAC - 4.9 amp full load 29.4 amp locked rotor. Pilot Rating: 470 VA at 125, 250 VAC. Resistive: 15 amp at 125, 250, or 480 VAC.

Electrical Connections: Screw type terminal.

Conduit Connection: 7/8" conduit hole.

Mounting Orientation: Horizontal duct flow

Set Point Adjustment: Screw type.

Weight: 1 lb, 1 oz (481.94 g)

CAUTION: For use only with air or non-combustible, non-corrosive gases. Unit is not sealed against dust.

Model 530 Air Flow Switch

Specifications - Installation and Operating Instructions

CAUTION: Vane edges are sharp. Use care when handling.

INSTALLATION

1. Select a location in a horizontal duct at least 10 duct diameters from fans and 7 diameters from elbows, size changes, etc. which can cause turbulence. Also, avoid areas with excess vibration or where the temperature limits might be exceeded. Switch can be mounted in any position.

2. Use vane as received for 8" (203 mm) or larger ducts. Trim at notch for 6" (152 mm) ducts.

3. Cut a mounting hole and slot for the vane and drill two 3/32" (2.38 mm) screw holes as shown in the full size drawing on the reverse side. Insert switch through slot and rotate 90° so arrow on switch enclosure points in direction of air flow. Attach switch to duct with sheet metal screws provided.

4. To make electrical connections, loosen the retaining screw and remove the conduit enclosure cover. The SPDT snap switch has screw terminals marked common, normally open and normally closed. A ground screw is also provided. On increasing flow the normally open contacts will close and the normally closed contacts will open as the set point is passed.

5. To adjust set point, turn the hex screw located near the ground screw. Rotate clockwise to increase setting or counter-clockwise to decrease.

6. After all electrical connections and adjustments are complete, replace conduit enclosure cover.

MAINTENANCE

The only adjustment is that of the set point. Care should be taken to keep switch dry and free of dust, dirt and oil. No lubrication or routine maintenance is necessary in normal service.

Full Size Mounting Template

