



Model 660 Air Velocity Monitor

Specifications - Installation and Operating Instructions

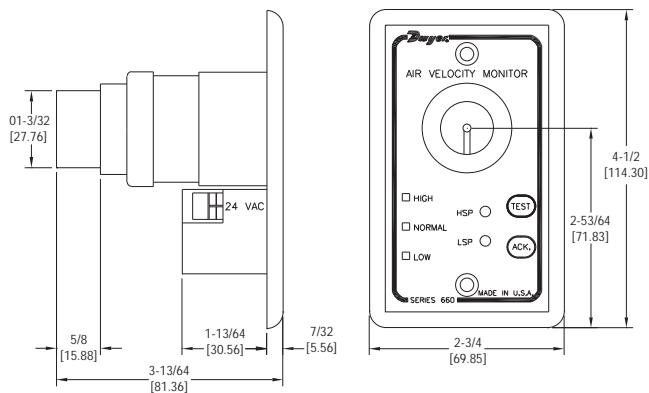
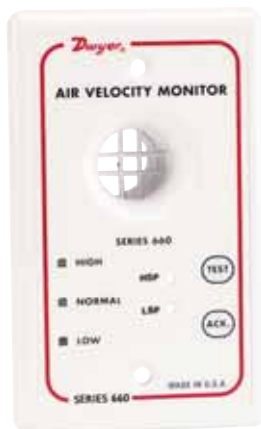

Fig. A

The Model 660 Air Velocity Monitor is an inexpensive accessory for laboratory fume hoods to indicate the approximate face velocity of airflow with the primary purpose of warning when a low flow condition occurs. Red, green and yellow LED's correspond to low, normal and high flow rates. When flow decreases from normal to low an audible alarm will also actuate requiring manual acknowledgment to silence. Settings for alarms must be individually adjusted for each fume hood because of the unique conditions within each one and its surrounding environment. This initial calibration procedure requires use of a suitable anemometer such as a Model 480 Vaneometer™, Model 471-1 Handheld Thermal Anemometer or comparable device to measure flow rates through the fume hood.

OPERATING PRINCIPLE

At the heart of the Model 660 AVM is a small constant temperature thermistor bead mounted in the center of the sensing tube. As moving air changes the thermistor output, electronic circuitry varies the current level to maintain temperature at a factory set standard condition. By comparing the amount of current necessary to maintain this standard versus normal current, velocity can be accurately measured and indicated through the LED's and the audible alarm.

This unit is typically mounted on the face of one of the fume hood sidewalls at a convenient viewing height. Flexible tubing is run to a location, defined in Fig. B, on the interior sidewall of the fume hood. In operation, the fume hood blower simultaneously draws air through both the open sash area of the fume hood and the opening in the 660 AVM. When sufficient change from the "normal" flow is detected, the lights change accordingly and if a low flow condition occurs, the audible alarm also sounds.

⚠CAUTION: Do Not Touch the glass enclosed thermistor bead inside the flow tube. It is very fragile and permanent damage, not covered by warranty, could result. See maintenance for cleaning recommendations.

SPECIFICATIONS

Service: Air and non-combustible, non-corrosive gases.

High Setpoint Range: 0-275 FPM (0-1.397 m/s).

Low Setpoint Range: 0-150 FPM (0-.792 m/s).

Repeatability: ±7% of full span, 0-50 and 150-275 FPM; ±5% of full span, 50-150 FPM.

Compensated Temperature Range: 50 to 90°F (32.2°C).

Operating Temperature Range: 32 to 120°F (0 to 48.9°C).

Power Supply: 24 VAC, 3 watts maximum.

Response Time: 6-10 seconds.

Warm-Up Time: 3-5 minutes (no flow).

Audible Alarm: 75 dB between 3-10 feet.

Weight: 3 oz (85 g).

Mounting Hardware: (2) #6 x 1" sheet metal screws, (2) 6-32 x 7/8" machine screws.

INSTALLATION

Tubing, bulkhead fitting and connectors are included with this device. This kit contains 3 ft of flexible tubing, one tube adapter with locknut, one 90° elbow adapter and power supply. Assembly drawing, fig. C, depicts installation using this kit.

1. Choose a clean, dry location with adequate rear space on the fascia of fume hood side wall, adjacent to the outlet hole location. See fig. D on reverse for full size mounting hole template. See Fig. D on reverse for full size mounting hole template. See Fig. B for outlet hole location.

2. Cut all openings and attach tubing between outlet hole and 660 AVM. As an alternative to flush panel mounting, a single gang electrical box can be used to surface mount unit by cutting an opening in the back large enough for tubing clearance. Make sure tubing is not kinked.

3. Loosen screws on electrical terminal block behind HIGH LED and insert power supply leads in side openings. Tighten screws, plug in power supply to outlet. Connect wire leads to 24 VAC power supply. On initial power application with no airflow, LED's will cycle from red-green-yellow-green-red with audible alarm on red. Alarm can be silenced by pressing ACK. pad.

