

Engine Air Intake Mass Flow Meter For Engine and Vehicle Testing Applications

Features

- High performance research-grade instrument
- 200 millisecond response to changes in flow rate
- High accuracy of +/- 1% of full scale over a broad range of flow ensures compliance with ISO 8178-1
- Outstanding 15:1 turndown gives high accuracy at low idle conditions
- Low pressure drop
- Plug and play operation with Sierra's BG[®]3 particulate sampling system
- Dual-plate laminar flow conditioning element for constrained piping environments
- Widely used in engine & vehicle testing applications
- Smart electronics permit field adjustment of critical flow meter settings
- Field validation of flow meter calibration
- 2 x 12 backlit LCD display
- CE approved
- Interfaces & Calibrates via BG3



SIERRA
CP ENGINEERING

CALIFORNIA:

5 Harris Court, Building L
Monterey, CA 93940
Tel 800/866.0200 or 831/373.0200
Fax 831/373.4402
www.sierra-cp.com

MICHIGAN:

16475 Igersoll Road
Lansing, MI 48906
Tel 517-323-8909
Fax 517-323-8910
info@sierra-cp.com

Your Engine Particulate Emissions Specialist.

AirTrak[™] 628S



Description

The AirTrak[™] 628S was originally designed to work specifically with Sierra's BG[®]3 engine emissions sampling system as an extremely fast, accurate, and repeatable engine air intake mass flow meter. However, the instrument has proven to be an excellent solution across the board in all engine testing applications.

AirTrak is specifically designed to measure engine air intake mass flow rate. The meter uses FastFlo[™] Sensor Technology for an extremely fast 200 millisecond response-time making it ideal for the toughest transient test cycles.

Integral Dual-Plate laminar flow conditioning elements and wide 15:1 turndown make AirTrak a flexible solution for the constrained piping environments commonly found in today's engine test cells.

In addition, the versatile microprocessor-based instrument integrates the functions of flow-range adjustment, meter validation and diagnostics in a probe-mounted NEMA 4X (IP65) housing. Mass flow rate and totalized flow, as well as other configuration variables, are displayed on the meter's 2 x 12 backlit LCD panel. AirTrak also provides an optical/galvanic isolated 4-20 mA output and two alarm outputs. The programmable transmitter is easily configured via RS 232 and Sierra's Smart Interface[™] Windows[™] based software or via three push buttons inside the instrument. AirTrak is available in body sizes from 1 inches to 24 inches (316 stainless steel tubing).

Dimensional Specifications

628S—Side View

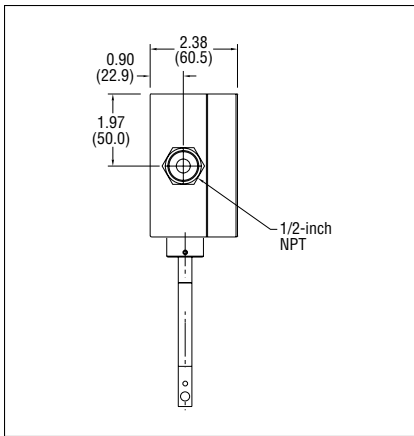

628S—Front View

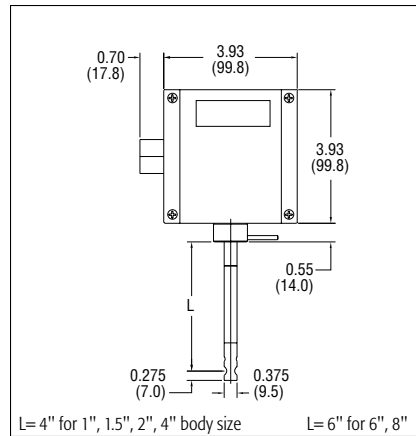

All dimensions are inches. Millimeters are in parentheses. Certified drawings are available on request.

Performance Specifications

Accuracy of Point Velocity

+/- 1% of full scale above 10% full scale

Repeatability

+/- 0.5% of full scale below 10% full scale

+/- 2% of reading above 10% full scale

Temperature Coefficient

+/- 0.02% of reading per °F within ± 50°F of customer specified conditions

+/- 0.03% of reading per °F within ± 50°F to 100°F of customer specified conditions

+/- 0.04% of reading per °C within ± 25°C of customer specified conditions

+/- 0.06% of reading per °C within ± 25°C to 50°C of customer specified conditions

Pressure Coefficient

0.02% per psi for air

Response Time

200 milliseconds to 63% of final velocity value

Operating Specifications

Gases

Air

Gas Pressure

120 psig (8 barg) maximum design pressure

Pressure Drop

Negligible

Gas & Ambient Temperature

Gas 14° to 176°F (-10° to 80°C)

Ambient 32° to 120°F (0° to 50°C)

Power Requirements

18 to 30 VDC (regulated), 625 mA maximum

Output Signal

Linear 0–5 VDC, 1000 ohms minimum load resistance or

Linear 4–20 mA proportional to mass flow rate,

700 ohms maximum resistance power supply dependent

User-selectable. Active non-galvanically separated or

passive galvanically separated (loop power required)

Alarms

Hard contact user-adjustable high and low

Dead band adjustable with Smart Interface™ software

Relay ratings Maximum 42 VAC or 42 VDC, 140 mA

Tables

BODY SIZES				
Code	L (in.)	OD (in.)	Max(SCFM)	ΔP(in H ₂ O)
BW1	4	1	109	40
BW1.5	6	1.5	245	50
BW2	8	2	436	50
BW4	16	4	1744	50
BW6	24	6	3924	60
BW8	32	8	6976	90

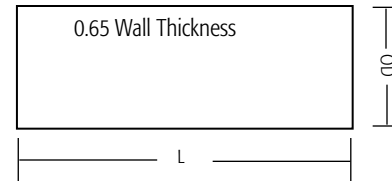

Operating Specifications (continued)

Displays

Alphanumeric 2 x 12 digit backlit LCD

Adjustable variables via on-board switches (password protected) or with Smart Interface™ software

Adjustable variables. . . Full scale (50 to 100 %)

Time Response (1 to 7 seconds)

Correction factor setting (0.5 to 5)

Zero and span

Totalizer

Eight digits (9,999,999) in engineering units

Resettable by software, on-board switches or external magnet

Software

Smart Interface™ Windows™-based software

Minimum 8 MB of RAM, preferred 16 MB of RAM

RS 232 communication

Additional features. . . Alarm dead band adjustment

Low flow cut-off adjustment

Linearization adjustment

Save / Load configurations

Flow meter validation

Physical Specifications

Wetted Material

Probe 316 SS

Flow Body 316 SS tubing

Sensor 304 SS, glass coating epoxy

Enclosure

NEMA 4X (IP65) powder-coated cast aluminum

Electrical Connections

One 1/2-inch female NPT

Certifications

CE approved

Ordering the AirTrak™ 628S

PARENT NUMBER

628 AirTrak™ Engine Air Intake Flow Meter

628S

BODY SIZE

BW1 1-inch (2.5 cm)

BW1.5 1.5-inch (3 cm)

BW2 2-inches (5 cm)

BW4 4-inches (10 cm)

BW6 6-inches (15 cm)

BW8 8-inches (20 cm)