

# Multivariable Mass Vortex Flow Meter

## Features

- Volumetric or mass flow monitoring of gases, liquids and steam
- Smart electronics extends range down to a Reynolds number of 5000
- Ideal for steam applications
- Selectable outputs for five process parameters in one integrated meter:
  - mass flow rate
  - volumetric flow rate
  - temperature
  - pressure
  - density
- Field-configurable ranges, alarms, outputs and displays
- Field configurable via six push buttons or magnet through explosion-proof window
- Rangeability up to 30:1
- Temperature up to 750° F
- Pressure up to 1500 psig
- In-line ( 1/2" to 8") and insertion (into pipes > 2") configurations
- FMC and ATEX approval
- Flow computer integrates AGA-8 equations for natural gas
- Full implementation of HART protocol
- Optional MODBUS protocol

**SIERRA**<sup>®</sup>  
**INSTRUMENTS**  
THE MASS FLOW COMPANY



For information online...

[www.sierrainstruments.com](http://www.sierrainstruments.com)

# Innova-Mass<sup>®</sup> Model 240 & 241



## Description

**S**ierra Instruments' Innova-Mass<sup>®</sup> Multivariable mass vortex flow meter provides a reading of up to five process parameters from a single entry point in the pipeline. The meter can measure the fluid's velocity, temperature, and pressure and calculate mass flow rate, volumetric flow rate and density. Sensing all process parameters at a single location in one integrated meter greatly improves measurement accuracy and reduces total installed cost.

The Innova-Mass Model 240 in-line meters are available in 0.5, 0.75, 1, 1.5, 2, 3, 4, 6 and 8-inch sizes with ANSI or DN16 flanges or wafer flow bodies. The Series 241 insertion meters can be used on pipe sizes from two inches and greater. Optional "hot-tap" hardware including packing gland probe seal, retractor, and isolation valves is also available.

### In-Line Dimensional Specifications

#### 240 Flanged In-line—Side View

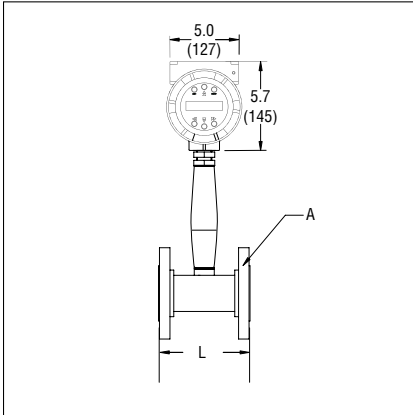

#### 240 Flanged In-line—Outlet View

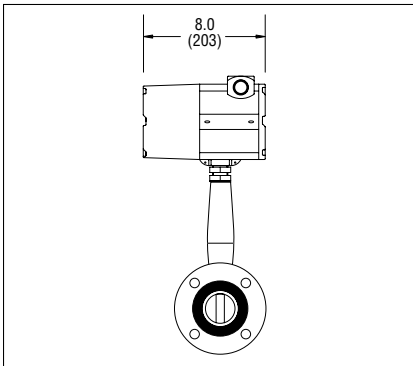

#### 240 Wafer—Side View

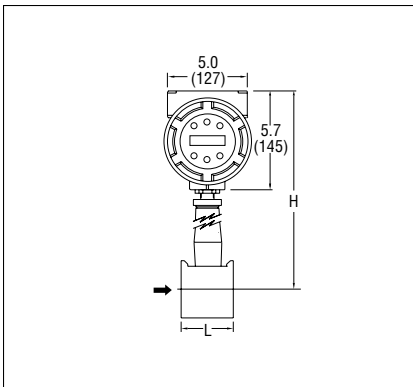

#### 240 Wafer—Outlet View

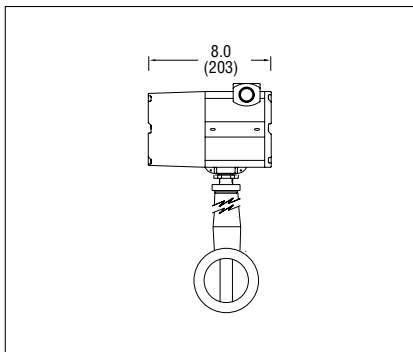

### In-Line Table

240 INNOVA-FLO® SIZES			
Flow Body Size	A	L	H
0.5-inch SCH. 80	150 lb Flange	4.56 (116)	14.8 (376)
	300 lb Flange	4.56 (116)	14.8 (376)
	600 lb Flange	4.56 (116)	14.8 (376)
	1.4 Wafer O.D.	4.56 (116)	14.8 (376)
0.75-inch SCH. 80	150 lb Flange	4.8 (122)	15.0 (381)
	300 lb Flange	4.8 (122)	15.0 (381)
	600 lb Flange	4.8 (122)	15.0 (381)
	1.7 Wafer O.D.	4.8 (122)	15.0 (381)
1-inch SCH. 80	150 lb Flange	4.94 (126)	15.0 (381)
	300 lb Flange	4.94 (126)	15.0 (381)
	600 lb Flange	4.94 (126)	15.0 (381)
	2.0 Wafer O.D.	2.8 (71)	14.8 (376)
1.5-inch SCH. 80	150 lb Flange	5.5 (140)	15.1 (384)
	300 lb Flange	5.5 (140)	15.1 (384)
	600 lb Flange	5.5 (140)	15.1 (384)
	2.9 Wafer O.D.	2.8 (71)	15.1 (384)
2-inch SCH. 80	150 lb Flange	6.0 (153)	15.3 (389)
	300 lb Flange	6.0 (153)	15.3 (389)
	600 lb Flange	6.0 (153)	15.3 (389)
	3.7 Wafer O.D.	3.0 (76)	15.3 (389)
3-inch SCH. 80	150 lb Flange	6.9 (175)	15.8 (401)
	300 lb Flange	6.9 (175)	15.8 (401)
	600 lb Flange	6.9 (175)	15.8 (401)
	5.0 Wafer O.D.	4.0 (102)	15.8 (400)
4-inch SCH. 80	150 lb Flange	8.0 (203)	16.2 (411)
	300 lb Flange	8.0 (203)	16.2 (411)
	600 lb Flange	8.0 (203)	16.2 (411)
	6.2 Wafer O.D.	4.7 (119)	16.2 (412)
6-inch SCH. 80	150 lb Flange	9.0 (229)	17.3 (439)
	300 lb Flange	9.0 (229)	17.3 (439)
	600 lb Flange	9.0 (229)	17.3 (439)
	8-inch SCH. 80	150 lb Flange	10.5 (267)
	300 lb Flange	10.5 (267)	18.2 (462)
	600 lb Flange	10.5 (267)	18.2 (462)

### Insertion Dimensional Specifications

#### Gate Valve

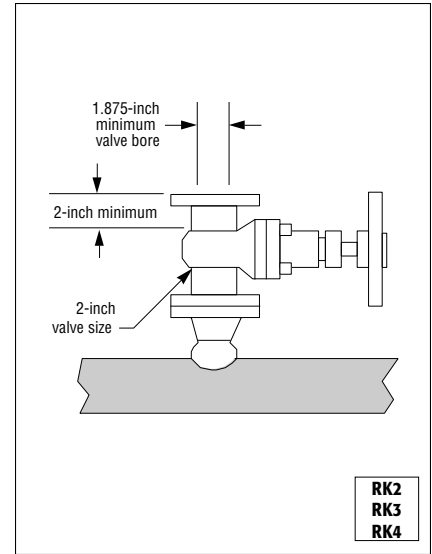

### Insertion Table

Model Code / Probe Seal / Process Connection
CM / Compression / Two-inch Male NPT
CF / Compression / 150 lb flange
CG / Compression / 300 lb flange
CH / Compression / 600 lb flange
PM / Packing Gland / Two-inch Male NPT <sup>1</sup>
PMR / Packing Gland / Two-inch Male NPT with Retractor <sup>2</sup>
PF / Packing Gland / 150 lb flange <sup>1</sup>
PFR / Packing Gland / 150 lb flange with Retractor <sup>2</sup>
PG / Packing Gland / 300 lb flange <sup>1</sup>
PGR / Packing Gland / 300 lb flange with Retractor <sup>2</sup>
PHR / Packing Gland / 600 lb flange with Retractor <sup>2</sup>

All dimensions are inches. Millimeters are in parentheses. Certified drawings are available on request.

Notes: (1) Can be used with removable retractor.  
(2) Retractor is permanently mounted to meter.

### 241 Compression, Flange

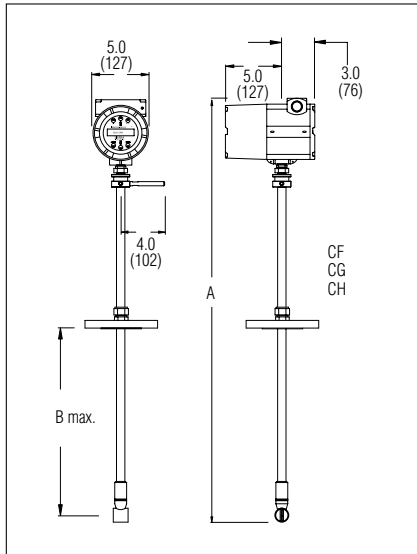

### 241 Compression, Male NPT

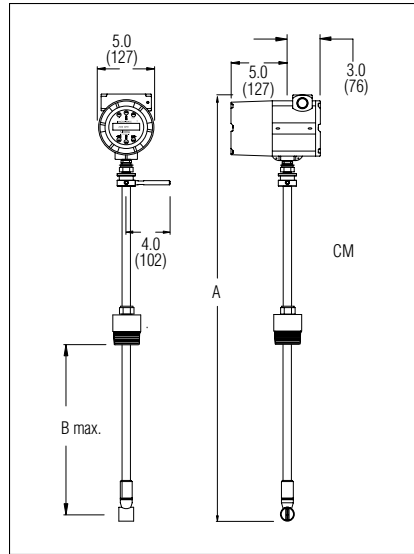

### 241 Packing Gland, Flange

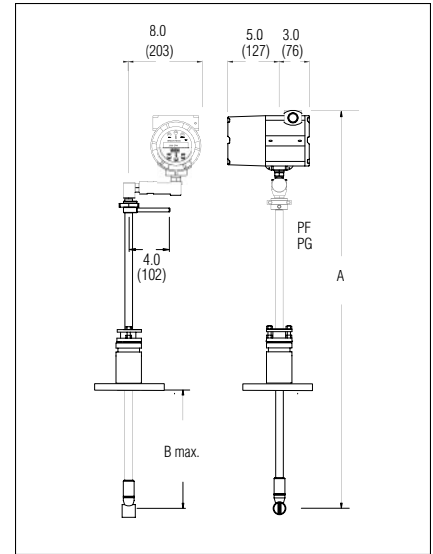

### 241 Packing Gland, Male NPT, Retractor

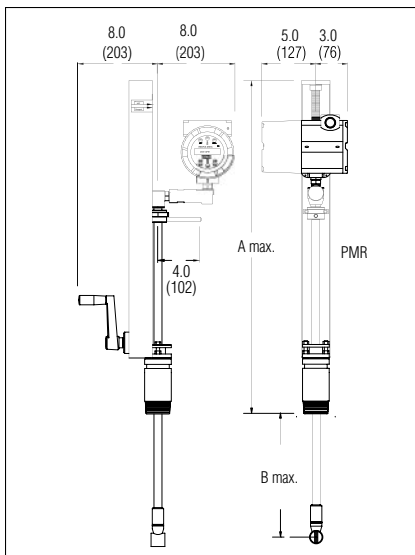

### 241 Packing Gland, Male NPT

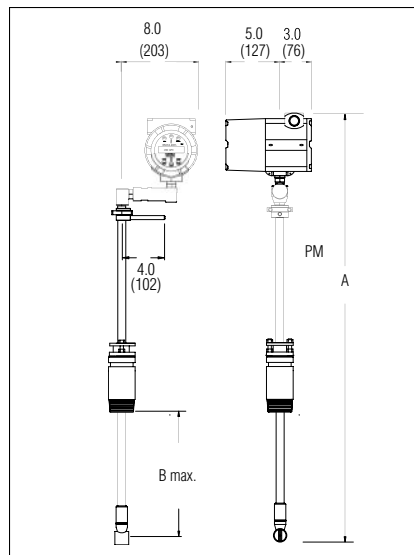

### 241 Packing Gland, Flange, Retractor

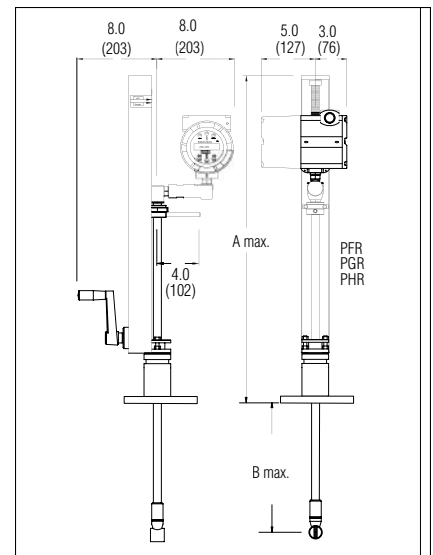

### 241 INNOVA-MASS® SIZES

Standard Probe		Compact Probe		Extended Probe	
A	B	A	B	A	B
41.0 (1041.0)	26.2 (665.0)	24.6 (625.0)	9.8 (249.0)	53.0 (1340.0)	38.2 (920.0)
41.0 (1041.0)	27.3 (639.0)	24.6 (625.0)	10.9 (277.0)	53.0 (1340.0)	39.3 (998.0)
41.0 (1041.0)	27.2 (691.0)	24.6 (625.0)	10.8 (274.0)	53.0 (1340.0)	39.2 (996.0)
41.0 (1041.0)	26.8 (681.0)	24.6 (625.0)	10.4 (264.0)	53.0 (1340.0)	38.8 (986.0)
40.5 (1029.0)	21.5 (546.0)	N/A	N/A	52.5 (1334.0)	33.5 (850.9)
40.5 (1029.0)	21.5 (546.0)	N/A	N/A	52.5 (1334.0)	33.5 (850.9)
40.5 (1029.0)	21.1 (536.0)	N/A	N/A	52.5 (1334.0)	33.1 (841.0)
40.5 (1029.0)	21.1 (536.0)	N/A	N/A	52.5 (1334.0)	33.1 (841.0)
40.5 (1029.0)	21.1 (536.0)	N/A	N/A	52.5 (1334.0)	33.1 (841.0)
40.5 (1029.0)	21.1 (536.0)	N/A	N/A	52.5 (1334.0)	33.1 (841.0)
40.5 (1029.0)	21.1 (536.0)	N/A	N/A	52.5 (1334.0)	33.1 (841.0)

## Dimensional Specifications

### 240/241 Remote—Front View

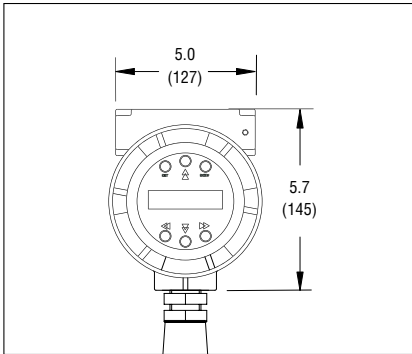

### 240/241 Remote—Side View

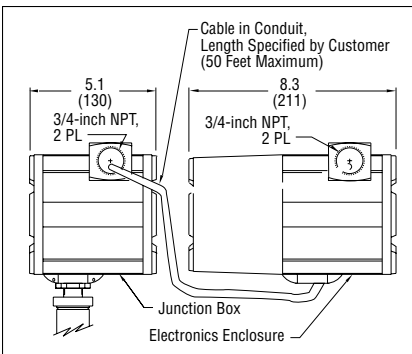

### Remote Rear Bracket Mounted Electronics

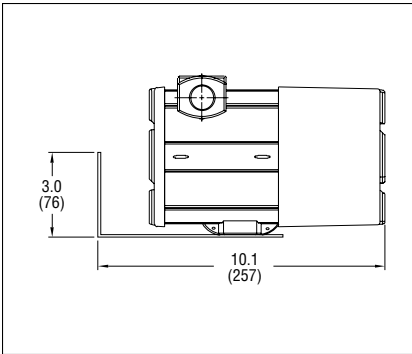

### Mounting Holes for Remote Rear Bracket

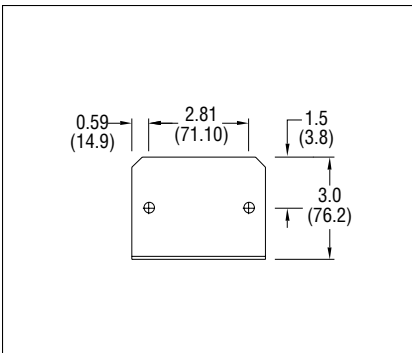

### STRAIGHT PIPE LENGTH REQUIREMENTS (In Number of Internal Diameters, D)

	Upstream	Downstream
One 90° elbow before meter	10 D	5 D
Two 90° elbows before meter	15 D	5 D
Two 90° elbows before meter out of plane (If three 90° bends present, double recommend length)	25 D	10 D
Reduction before meter	10 D	5 D
Expansion before meter	20 D	5 D
Regulator or valve partially closed before meter (If valve wide open, base length requirements on fitting directly preceding it)	25 D	10 D

### Weight

#### 240 IN-LINE METER

Connection Size	ANSI 150 lb		ANSI 300 lb		ANSI 600 lb	
	lb	kg	lb	kg	lb	kg
0.5-inch flange	12.0	5.5	12.5	5.7	13	5.9
0.75-inch flange	13.0	5.9	14.0	6.4	14.5	6.6
1-inch flange	13.5	6.1	16.4	7.4	16.4	7.4
1.5-inch flange	14.6	6.6	22.7	10.3	24.8	11.2
2-inch flange	19.5	8.8	26.9	12.2	33.2	15.1
3-inch flange	27.5	12.5	39.5	17.9	56.3	25.5
4-inch flange	43.5	19.7	60.5	27.4	96.2	43.6
6-inch flange	48.4	22.0	96.2	43.6	178	80.8
8-inch flange	71.0	32.2	149	67.4	300	136
1-inch wafer	—	—	—	—	10.1	4.6
1.5-inch wafer	—	—	—	—	11.8	5.4
2-inch wafer	—	—	—	—	14.2	6.4
3-inch wafer	—	—	—	—	22.7	10.3
4-inch wafer	—	—	—	—	33.0	15.0

#### 241 INSERTION METER

Connection Size	lb	kg
Compression Fitting, Male NPT	13.8	6.2
Compression Fitting, 150 lb Flange	16.3	7.3
Compression Fitting, 300 lb Flange	18.3	8.3
Compression Fitting, 600 lb Flange	19.3	8.7
Packing Gland, Male NPT	15.8	7.1
Packing Gland, Male NPT with Retractor	25.3	11.5
Packing Gland, 150 lb Flange	20.8	9.4
Packing Gland, 150 lb Flange with Retractor	30.3	13.7
Packing Gland, 300 lb Flange	24.8	11.3
Packing Gland, 300 lb Flange with Retractor	34.3	15.5
Packing Gland, 600 lb Flange with Retractor	35.3	16.0

## Performance Specifications

### Accuracy

Process Variables	240 Series In-Line Meters		241 Series Insertion Meters <sup>(1)</sup>	
	Liquids	Gas and Steam	Liquids	Gas and Steam
Mass Flow Rate	+/- 1% of rate over a 30:1 range <sup>(3)</sup>	+/- 1.5% of rate <sup>(2)</sup> over a 30:1 range <sup>(3)</sup>	+/- 1.5% of rate over a 30:1 range <sup>(3)</sup>	+/- 2% of rate <sup>(2)</sup> over a 30:1 range <sup>(3)</sup>
Volumetric Flow Rate	+/- 0.7% of rate over a 30:1 range <sup>(3)</sup>	+/- 1% of rate over a 30:1 range <sup>(3)</sup>	+/- 1.2% of rate over a 30:1 range <sup>(3)</sup>	+/- 1.5% of rate over a 30:1 range <sup>(3)</sup>
Temperature	+/- 2° F (+/- 1° C)	+/- 2° F (+/- 1° C)	+/- 2° F (+/- 1° C)	+/- 2° F (+/- 1° C)
Pressure	0.4% of transducer full scale	0.4% of transducer full scale	0.4% of transducer full scale	0.4% of transducer full scale
Density	0.3% of reading	0.5% of reading <sup>(2)</sup>	0.3% of reading	0.5% of reading <sup>(2)</sup>

- Notes: (1) Accuracies stated are for the total mass flow through the pipe.  
 (2) Over 50 to 100% of the pressure transducer's full scale.  
 (3) Nominal rangeability is stated. Precise rangeability depends on fluid and pipe size.

### Repeatability

- Mass Flow Rate . . . . . +/- 0.2% of reading  
 Volumetric Flow Rate . . +/- 0.1% of reading  
 Temperature . . . . . +/- 0.2° F (+/- 0.1° C)  
 Pressure . . . . . +/- 0.05% of full scale  
 Density . . . . . +/- 0.1% of reading

### Stability Over 12 Months

- Mass Flow Rate . . . . . +/- 0.2% of reading maximum  
 Volumetric Flow Rate . . Negligible error  
 Temperature . . . . . +/- 0.1° F (+/- 0.5° C) maximum  
 Pressure . . . . . +/- 0.1% of full scale maximum  
 Density . . . . . +/- 0.1% of reading maximum

### Response Time

Adjustable from 1 to 100 seconds

## Operating Specifications

### Material Compatibility

- 240 . . . . . Any gas, liquid or steam compatible with 316L stainless steel, C276 Hastalloy® or A105 carbon steel. Not recommended for multi-phase fluids.  
 241 . . . . . Any gas, liquid or steam compatible with 316L stainless steel. Not recommended for multi-phase fluids.

### Flow Rates

Typical mass flow ranges are given in the following table. Precise flow ranges depend on the fluid and pipe size. 241 insertion meters are applicable to pipe sizes from 2-inch and greater. Consult factory for sizing program.

WATER MINIMUM AND MAXIMUM FLOW RATES									
	0.5-In.	0.75-In.	1-Inch	1.5-Inch	2-Inch	3-Inch	4-Inch	6-Inch	8-Inch
gpm	0.9	3	2.2	5.5	9.2	21	36	81	142
	22	40	67	166	276	618	1076	2437	4270
m <sup>3</sup> /hr	0.2	0.7	0.5	1.3	2.1	4.7	8.1	18	32
	5	9	15	38	63	140	244	554	970

AIR MINIMUM AND MAXIMUM FLOW RATES (scfm) <sup>(1)</sup>									
Pressure	0.5-In.	0.75-In.	1-Inch	1.5-Inch	2-Inch	3-Inch	4-Inch	6-Inch	8-Inch
0 psig	1.8	3	5	13	22	50	88	198	347
	17	40	90	221	369	826	1438	3258	5708
100 psig	4.9	9	15	37	62	138	240	543	952
	135	318	701	1728	2879	6447	11222	25421	44536
200 psig	7	12	20	50	83	185	322	730	1279
	255	608	1313	4740	5389	12067	21006	47585	67122
300 psig	8.5	15	24	59	98	220	382	866	1518
	375	893	1924	4750	7900	17687	30789	48821	64552
400 psig	10	17	27	66	110	247	430	975	1708
	500	1178	2535	6246	10410	23308	31141	46884	61990
500 psig	11	21	29	72	120	270	469	1063	1862
	620	1464	3147	7752	12920	22592	29834	44915	59387

Note: (1) Standard conditions are 70° F and 1 atmosphere.

SATURATED STEAM MINIMUM AND MAXIMUM FLOW RATES (lb/hr)									
Pressure	0.5-In.	0.75-In.	1-Inch	1.5-Inch	2-Inch	3-Inch	4-Inch	6-Inch	8-Inch
5 psig	5.7	12	20	49	82	183	319	722	1265
	52	122	265	652	1087	2434	4237	9598	16815
100 psig	7.1	28	46	112	187	419	729	1651	2893
	270	639	1385	3413	5688	12735	22168	50219	87980
200 psig	13	37	61	151	252	565	984	2229	3905
	495	1164	2524	6217	10362	23200	40385	91485	160275
300 psig	19	45	74	182	304	681	1185	2685	4704
	718	1690	3662	9021	15035	33664	58601	132750	232570
400 psig	25	52	85	209	349	781	1359	3078	5393
	944	2220	4814	11859	19764	44253	77033	174505	305721
500 psig	30	58	95	233	389	870	1515	3433	6014
	1176	2640	5986	14745	24575	55025	95784	216983	331080

### Differential Pressure Requirements, $\Delta P$

Permanent pressure loss of in-line meters for air at 68°F (20°C) and 14.70 psi (1.104 bara).  
 Permanent pressure loss of in-line meters for water at 68°F (20°C).

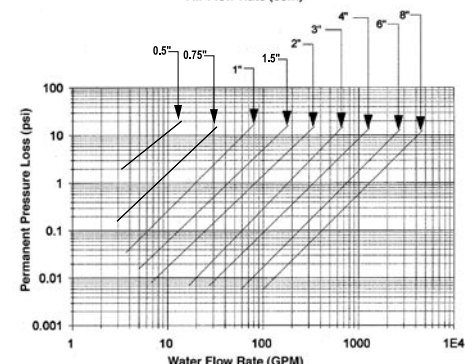
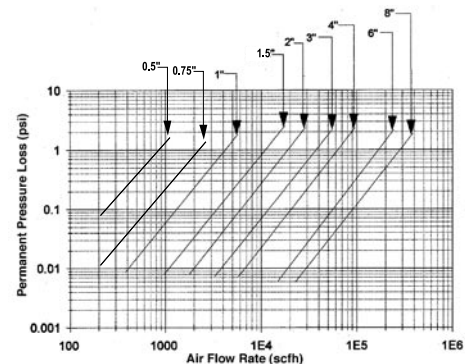

## Linear Range

Smart electronics corrects for lower flow down to a Reynolds number of 5,000. The Reynolds number is calculated using the fluid's actual temperature and pressure monitored by the meter. Rangeability depends on the fluid, process connections and pipe size. Consult factory for your application. Velocity rangeability under ideal conditions is as follows:

Liquids 30:1	1 foot per second velocity minimum 30 feet per second velocity maximum
Gases 30:1	10 feet per second velocity minimum 300 feet per second velocity maximum

## Process Fluid Pressure

240 PRESSURE RATINGS		
PROCESS CONNECTION	MATERIAL	RATING
Flanged	316L SS, A105 Carbon Steel, C276 Hastalloy®	150, 300, 600 lb
Wafer	316L SS, A105 Carbon Steel, C276 Hastalloy®	600 lb

241 PRESSURE RATINGS				
Probe Seal	Process Connection	Material	Rating	Ordering Code
Compression Fitting	2-inch Male NPT	316 L SS	ANSI 600 lb	CM
	2-inch 150 lb flange	316 L SS	ANSI 150 lb	CF
	2-inch 300 lb flange	316 L SS	ANSI 300 lb	CG
	2-inch 600 lb flange	316 L SS	ANSI 600 lb	CH
Packing Gland	2-inch Male NPT	316 L SS	50 psig	PM
	2-inch 150 lb flange	316 L SS	50 psig	PF
	2-inch 300 lb flange	316 L SS	50 psig	PG
Packing Gland with Removable Retractor	2-inch Male NPT	316 L SS	ANSI 300 lb	PM, RR
	2-inch 150 lb flange	316 L SS	ANSI 150 lb	PF, RR
	2-inch 300 lb flange	316 L SS	ANSI 300 lb	PG, RR
Packing Gland with Permanent Retractor	2-inch Male NPT	316 L SS	ANSI 600 lb	PMR
	2-inch 150 lb flange	316 L SS	ANSI 150 lb	PFR
	2-inch 300 lb flange	316 L SS	ANSI 300 lb	PGR
	2-inch 600 lb flange	316 L SS	ANSI 600 lb	PHR

## Pressure Transducer Ranges

PRESSURE SENSOR RANGES <sup>(1)</sup> , psia(bar)			
Full Scale Operating Pressure		Maximum Over-Range Pressure	
psia	(bara)	psia	(bara)
30	2	60	4
100	7	200	14
300	20	600	41
500	34	1000	69

Note: (1) To maximize accuracy, specify the lowest full scale operating pressure range for the application. To avoid damage, the flow meter must never be subjected to pressure above the over-range pressure shown above.

## Power Requirements

12 to 36 VDC, 100 mA (add 20mA per output up to 60mA)  
100 to 240 VAC, 50/60 Hz, 25 watts

## Display

Alphanumeric 2 x 16 LCD digital display  
Six push buttons switches (up, down, right, left, enter, exit) operable through the display glass of the explosion-proof enclosure Viewing at 90° mounting intervals

Teflon is a registered trademark of DuPont.

## Process Fluid & Ambient Temperature

Process Fluid	Standard Temperature Sensor: -40°F to 460°F (-40° to 260°C) High Temperature Sensor: -40°F to 750°F (40° to 400°C)
Ambient	Operating: -5°F to 140°F (-20° to 60°C) Storage: -40°F to 150°F (-40° to 65°C) 0-98% relative humidity, non-condensing conditions

## Output Signals<sup>(1)</sup>

Analog	One to three field rangeable, simultaneous linear 4-20 mA output signals (1000 ohms maximum loop resistance) selected by user from the five parameters—mass flow rate, volumetric flow rate, temperature, pressure and density
Pulse	Pulse output for totalization is a 50-millisecond duration pulse operating a solid-state relay capable of switching 40 VDC, 40 mA maximum HART standard, Optional MODBUS RTU.

Note: (1) All outputs are optically isolated and require external power for operation

## Alarms

Up to three programmable solid-state relays for high, low or window alarms capable of switching 40 VDC, 40 mA maximum

## Totalizer

Based on user-determined flow units, nine full digits, with rollover at 4, 294, 967, 295. Total stored in non-volatile memory

## Physical Specifications

### Wetted Materials

240	316L stainless steel standard C276 hastalloy® or A105 carbon steel optional Teflon-based thread sealant on pressure transducer
241	316L stainless steel Teflon® packing gland below 500°F (260°C) Graphite packing gland above 500°F (260°C) Teflon-based thread sealant on pressure transducer

### Enclosure

NEMA 4X (IP65) cast enclosure

### Electrical Ports

Two 3/4-inch female NPT ports

### Mounting Connections

240	Wafer or 150, 300, 600 lb ANSI flange
241	Permanent Installation: Two inch Male NPT; 150, 300, 600 lb ANSI flange with compression fitting probe seal Hot Tap <sup>(1)</sup> Installation: Two inch Male NPT; 150, 300, 600 lb ANSI flange; and optional retractor with packing gland probe seal

Note: (1) Removable under line pressure.

### Mounting Position

240	No effect
241	Meter must be perpendicular within +/- 5° of the pipe centerline

### FMC Approval

Explosion proof for Class I, Division 1, Groups B, C & D.  
Dust-ignition proof for Class II/III, Division 1, Groups E, F & G.

NEMA Type 4x and IP66  
T6 at Tamb=60°C

### Optional Certifications

Construction and Inspection (ANSI/ASME B31.3)  
Materials (NACE MR-01-75(90))

### ATEX Approval

II 2 G Ex d II B + H2 T6  
II 2 D Ex t D A 21 IP66 T6  
KEMA 08 ATEX 0143

### CE Approval

0344

## Ordering the Model 240 In-Line

Continued on Next Page >>

240

**PARENT MODEL NUMBER**

**240** Innova-Mass™ Multivariable In-line Mass Vortex Flow Meter

**PROCESS FLUID**

- V** Volumetric Vortex Flow Meter
- VT** Velocity and Temperature Sensors
- VTP** Velocity, Temperature and Pressure Sensors
- VTEP** Velocity and Temperature Sensors with external pressure sensor output
- VT EMS** VT Meter plus Energy meter Package.
- VTP EMS** VTP Meters plus Energy meter package.

**FLOW BODY—316L STAINLESS STEEL**

- F2** 1/2-inch ANSI 150 lb Flanged, 316L
  - F3** 3/4-inch ANSI 150 lb Flanged, 316L
  - F4** 1-inch ANSI 150 lb Flanged, 316L
  - F5** 1.5-inch ANSI 150 lb Flanged, 316L
  - F6** 2-inch ANSI 150 lb Flanged, 316L
  - F7** 3-inch ANSI 150 lb Flanged, 316L
  - F8** 4-inch ANSI 150 lb Flanged, 316L
  - F9** 6-inch ANSI 150 lb Flanged, 316L
  - F10** 8-inch ANSI 150 lb Flanged, 316L
- Also available in C276 Hastalloy. Consult Factory For Pricing/Delivery*
- G2** 1/2-inch ANSI 300 lb Flanged, 316L
  - G3** 3/4-inch ANSI 300 lb Flanged, 316L
  - G4** 1-inch ANSI 300 lb Flanged, 316L
  - G5** 1.5-inch ANSI 300 lb Flanged, 316L
  - G6** 2-inch ANSI 300 lb Flanged, 316L
  - G7** 3-inch ANSI 300 lb Flanged, 316L
  - G8** 4-inch ANSI 300 lb Flanged, 316L
  - G9** 6-inch ANSI 300 lb Flanged, 316L
  - G10** 8-inch ANSI 300 lb Flanged, 316L
- Also available in C276 Hastalloy. Consult Factory For Pricing/Delivery*
- H2** 1/2-inch ANSI 600 lb Flanged, 316L
  - H3** 3/4-inch ANSI 600 lb Flanged, 316L
  - H4** 1-inch ANSI 600 lb Flanged, 316L
  - H5** 1.5-inch ANSI 600 lb Flanged, 316L
  - H6** 2-inch ANSI 600 lb Flanged, 316L
  - H7** 3-inch ANSI 600 lb Flanged, 316L
  - H8** 4-inch ANSI 600 lb Flanged, 316L
  - H9** 6-inch ANSI 600 lb Flanged, 316L
  - H10** 8-inch ANSI 600 lb Flanged, 316L
- Also available in C276 Hastalloy. Consult Factory For Pricing/Delivery*
- W2** 0.5-inch Wafer connection, 316L
  - W3** 3/4-inch Wafer connection, 316L
  - W4** 1-inch Wafer connection, 316L
  - W5** 1.5-inch Wafer connection, 316L
  - W6** 2-inch Wafer connection, 316L
  - W7** 3-inch Wafer connection, 316L
  - W8** 4-inch Wafer connection, 316L
- Also available in C276 Hastalloy. Consult Factory For Pricing/Delivery*
- FC4** 1-inch ANSI 150 lb Flanged, Carbon Steel
  - FC5** 1.5-inch ANSI 150 lb Flanged, Carbon Steel
  - FC6** 2-inch ANSI 150 lb Flanged, Carbon Steel
  - FC7** 3-inch ANSI 150 lb Flanged, Carbon Steel
  - FC8** 4-inch ANSI 150 lb Flanged, Carbon Steel
  - FC9** 6-inch ANSI 150 lb Flanged, Carbon Steel
  - FC10** 8-inch ANSI 150 lb Flanged, Carbon Steel
- Also available in C276 Hastalloy. Consult Factory For Pricing/Delivery*

**FLOW BODY—316L STAINLESS STEEL (CONTINUED)**

- GC4** 1-inch ANSI 300 lb Flanged, Carbon Steel
  - GC5** 1.5-inch ANSI 300 lb Flanged, Carbon Steel
  - GC6** 2-inch ANSI 300 lb Flanged, Carbon Steel
  - GC7** 3-inch ANSI 300 lb Flanged, Carbon Steel
  - GC8** 4-inch ANSI 300 lb Flanged, Carbon Steel
  - GC9** 6-inch ANSI 300 lb Flanged, Carbon Steel
  - GC10** 8-inch ANSI 300 lb Flanged, Carbon Steel
- Also available in C276 Hastalloy. Consult Factory For Pricing/Delivery*
- HC4** 1-inch ANSI 600 lb Flanged, Carbon Steel
  - HC5** 1.5-inch ANSI 600 lb Flanged, Carbon Steel
  - HC6** 2-inch ANSI 600 lb Flanged, Carbon Steel
  - HC7** 3-inch ANSI 600 lb Flanged, Carbon Steel
  - HC8** 4-inch ANSI 600 lb Flanged, Carbon Steel
  - HC9** 6-inch ANSI 600 lb Flanged, Carbon Steel
  - HC10** 8-inch ANSI 600 lb Flanged, Carbon Steel
- Also available in C276 Hastalloy. Consult Factory For Pricing/Delivery*
- FD2** DN15/PN16 Flanged, 316L
  - FD3** DN20/PN16 Flanged, 316L
  - FD4** DN25/PN16 Flanged, 316L
  - FD5** DN40/PN16 Flanged, 316L
  - FD6** DN50/PN16 Flanged, 316L
  - FD7** DN80/PN16 Flanged, 316L
  - FD8** DN100/PN16 Flanged, 316L
  - FD9** DN150/PN16 Flanged, 316L
  - FD10** DN200/PN16 Flanged, 316L
- Also available in C276 Hastalloy. Consult Factory For Pricing/Delivery*
- GD2** DN15/PN40 Flanged, 316L
  - GD3** DN20/PN40 Flanged, 316L
  - GD4** DN25/PN40 Flanged, 316L
  - GD5** DN40/PN40 Flanged, 316L
  - GD6** DN50/PN40 Flanged, 316L
  - GD7** DN80/PN40 Flanged, 316L
  - GD8** DN100/PN40 Flanged, 316L
  - GD9** DN150/PN40 Flanged, 316L
  - GD10** DN200/PN40 Flanged, 316L
- Also available in C276 Hastalloy. Consult Factory For Pricing/Delivery*
- HD2** DN15/PN64 Flanged, 316L
  - HD3** DN20/PN64 Flanged, 316L
  - HD4** DN25/PN64 Flanged, 316L
  - HD5** DN40/PN64 Flanged, 316L
  - HD6** DN50/PN64 Flanged, 316L
  - HD7** DN80/PN64 Flanged, 316L
  - HD8** DN100/PN64 Flanged, 316L
  - HD9** DN150/PN64 Flanged, 316L
  - HD10** DN200/PN64 Flanged, 316L
- Also available in C276 Hastalloy. Consult Factory For Pricing/Delivery*

## Ordering the Model 240 In-Line (Continued)

240
\*
\*

\*From Previous Page

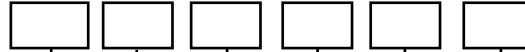

**ELECTRONICS ENCLOSURE**

- E2** NEMA 4X (IP65) Enclosure - Mounted on Probe
- E4** Remote Electronics NEMA 4X (IP65) includes NEMA 4X (IP65) on Probe  
Specify cable length in parentheses, maximum 50 feet (17m).

**DISPLAY OPTION**

- NR** No Display
- DD** Digital Display

**INPUT POWER**

- PV1L** 12-36 VDC LOOP POWERED (available only with V4LH)
- PV1** 12-36 VDC
- PS** 100-240 VAC, 50/60 Hz Line Power, 25 Watts

**OUTPUT**

- V4LH** One analog output (4-20 mA), one pulse, HART. LOOP POWERED
- V4H** One analog output (4-20 mA), one alarm, one pulse and HART Communication. NOT LOOP POWERED
- V4M** One analog output (4-20 mA), one alarm, one pulse, and MODBUS.
- V6M** Three analog outputs (4-20 mA), three alarms, one pulse, MODBUS
- V6H** Three analog outputs (4-20 mA), three alarms, one pulse, HART Protocol Communication

**PROCESS TEMPERATURE**

- ST** Standard temperature  
Process temperature -40° to 500°F (-40° to 260°C)
- HT** High Temperature  
Process temperature -40° to 750°F (-40° to 400°C)

**PROCESS PRESSURE**

- MP0** No Pressure Sensor Used with VT process fluid.
- MP1** Maximum 30 psia (2 bara), Proof 60 psia (4 bara )
- MP2** Maximum 100 psia (7 bara), Proof 200 psia (14 bara )
- MP3** Maximum 300 psia (20 bara), Proof 600 psia (41 bara )
- MP4** Maximum 500 psia (34 bara), Proof 1000 psia (64 bara )
- MP5** Maximum 1500 psia (100 bara), Proof 1500 psia (100 bara )

**ACCESSORIES** (Consult Factory) Removable Retractors, Isolated Gate Valves, Mounting Kits, Material Certificates, Pressure Certificates, Certificate of Conformance, NACE Certification



## Ordering the Model 241 Insertion

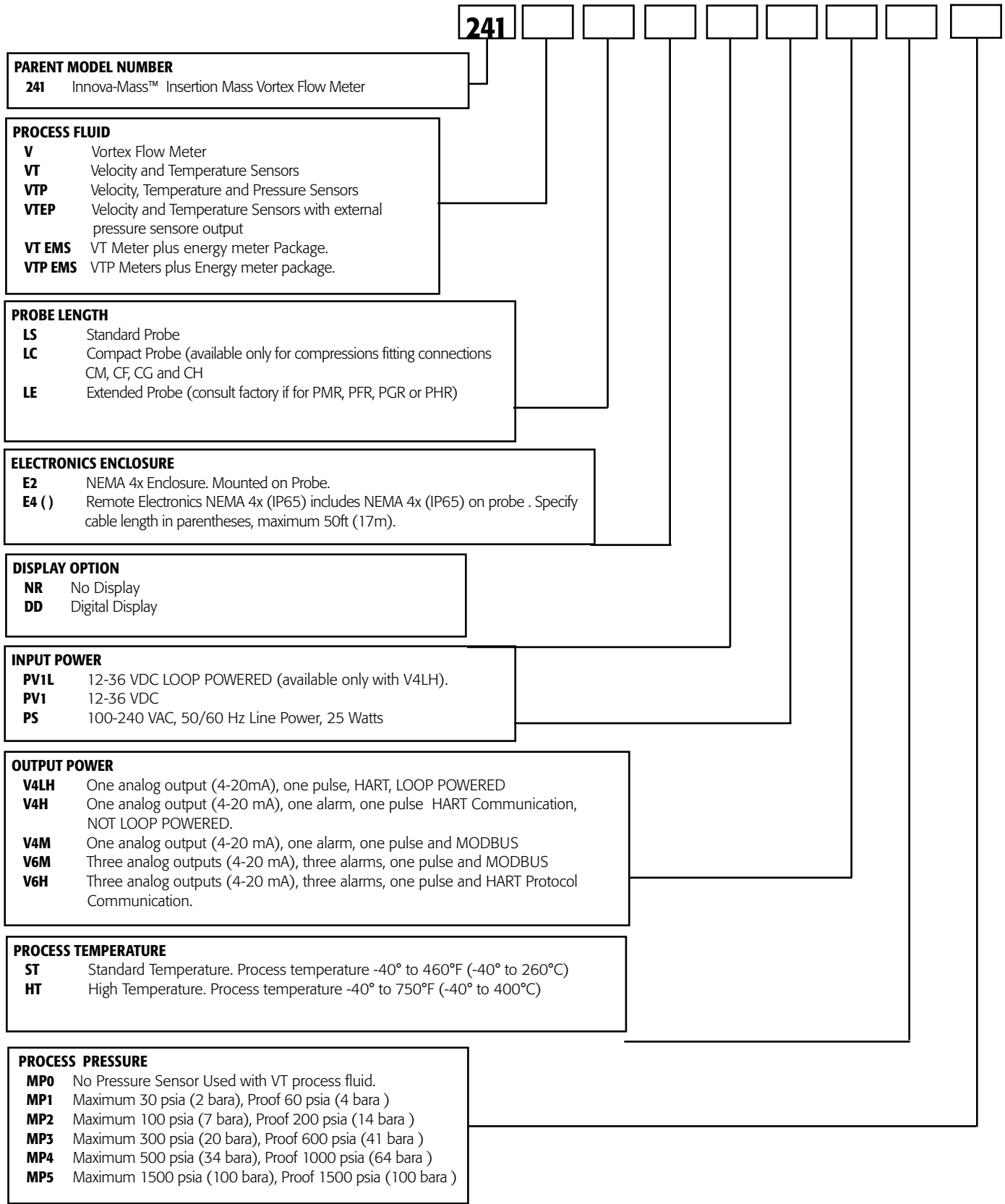

**ACCESSORIES** (Consult Factory) Removable Retractors, Isolated Gate Valves, Mounting Kits, Material Certificates, Pressure Certificates, Certificate of Conformance, NACE Certification

## Ordering the Model 241 Insertion

241 \* \* \* \* \* \* \*

\*From Previous Page

### PROCESS CONNECTION

<b>CM</b>	<b>Compression Fitting</b> 2-inch Male NPT, 600 lb pressure rating.	<b>CFD</b>	<b>Compression Fitting</b> DN50/PN16 Flange.
<b>CF</b>	<b>Compression Fitting</b> 2-inch 150 lb Flange.	<b>CGD</b>	<b>Compression Fitting</b> DN50/PN40 Flange.
<b>CG</b>	<b>Compression Fitting</b> 2-inch 300 lb Flange.	<b>CHD</b>	<b>Compression Fitting</b> DN50/PN64 Flange.
<b>CH</b>	<b>Compression Fitting</b> 2-inch 600 lb Flange.	<b>PFD</b>	<b>Packing Gland</b> DN50/PN16 Flange, 50 psig (3.5 barg) maximum process pressure
<b>PM</b>	<b>Packing Gland</b> 2-inch Male NPT, 50 psig (3.5 barg) maximum process pressure without removable retractor.	<b>PFDR</b>	<b>Packing Gland</b> DN50/PN16 Flange, with retractor.
<b>PMR</b>	<b>Packing Gland</b> 2-inch Male NPT with Retractor, 600 lb pressure rating.	<b>PFDR-LE</b>	<b>Packing Gland</b> DN50/PN16 Flange, with retractor. For use with Extended probe length (see LE option)
<b>PMR-LE</b>	<b>Packing Gland</b> 2-inch Male NPT with Retractor, 600 lb pressure rating. (for LE)	<b>PGD</b>	<b>Packing Gland</b> DN50/PN40 Flange, 50 psig (3.5 barg) maximum process pressure
<b>PF</b>	<b>Packing Gland</b> 2-inch 150 lb Flange, 50 psig (3.5 barg) maximum process pressure without removable retractor	<b>PGDR</b>	<b>Packing Gland</b> DN50/PN40 Flange, with retractor.
<b>PFR</b>	<b>Packing Gland</b> 2-inch 150 lb Flange with Retractor	<b>PGDR-LE</b>	<b>Packing Gland</b> DN50/PN40 Flange, with retractor. For use with Extended probe length (see LE option)
<b>PFR-LE</b>	<b>Packing Gland 2-inch 150 lb Flange with Retractor</b> For use with Extended probe length (see LE option)	<b>PHD</b>	<b>Packing Gland</b> DN50/PN64 Flange, 50 psig (3.5 barg) maximum process pressure
<b>PG</b>	<b>Packing Gland</b> 2-inch 300 lb Flange, 50 psig (3.5 barg) maximum process pressure without removable retractor.	<b>PHDR</b>	<b>Packing Gland</b> DN50/PN64 Flange, with retractor.
<b>PGR</b>	<b>Packing Gland</b> 2-inch 300 lb Flange with Retractor	<b>PHDR-LE</b>	<b>Packing Gland</b> DN50/PN64 Flange, with retractor. For use with Extended probe length (see LE option)
<b>PGR-LE</b>	<b>Packing Gland 2-inch 300 lb Flange with Retractor</b> For use with Extended probe length (see LE option)		
<b>PH</b>	<b>Packing Gland</b> 2-inch 600 lb Flange, 50 psig (3.5 barg) maximum process pressure without removable retractor		
<b>PHR</b>	<b>Packing Gland</b> 2-inch 600 lb Flange with Retractor		
<b>PHR-LE</b>	<b>Packing Gland 2-inch 600 lb Flange with Retractor</b> For use with Extended probe length (see LE option)		



**SIERRA**<sup>®</sup>  
**INSTRUMENTS**  
THE MASS FLOW COMPANY

SIERRA INSTRUMENTS, NORTH AMERICA • 5 Harris Court, Building L • Monterey, California • (800) 866-0200 • (831) 373-0200 • Fax (831) 373-4402 • www.sierrainstruments.com  
SIERRA INSTRUMENTS, EUROPE • Bijlmansweid 2 • 1934RE Egmond aan den Hoef • The Netherlands • +31 72 5071400 • Fax: +31 72 5071401  
SIERRA INSTRUMENTS, ASIA • Rm.618, Tomson Centre, Bldg. A • 188 Zhang Yang Road • Pu Dong New District • Shanghai, P.R. China 200122 • +8621 5879 8521/22 • Fax: +8621 5879 8586