

Max-Trak™ Model 180

Technical Data Sheet

NEMA 6 / IP67 Compliant

Industrial Mass Flow

Meters and Controllers For Gases

Features

- Industry's only NEMA 6/IP67 industrial MFC affords wash down protection eliminating the need for secondary enclosures
- Measure & Control gas mass flow rates up to 1000 SLPM (other Sierra mass flow meters available up to 100,000 SLPM & higher)
- Accuracy: +/-1% of Full Scale
- Repeatability: +/- 0.2% Full Scale ensures a stable process even under changing conditions
- Dial-A-Gas® lets you select from up to 10 gases in one instrument, creating great flexibility and reducing spares inventory
- Operation at low differential pressures possible due to powerful direct valve design
- Both digital and analog communication included
- View and change the following functions in the field via RS-232 or our unique Pilot Module:
 - Gas
 - Setpoint Value
 - Setpoint source
 - Engineering units
 - Output signal
 - Valve state
 - Full scale value
 - Password
- 316 stainless steel construction is suitable for any clean gas, even corrosives & toxics
- Single sided power (24 VDC) reduces installation cost
- Free Software Included For Windows OS



Description

Max-Trak™ is an industrial mass flow controller from the company that has been a trusted name in industrial thermal mass flow meters for decades—Sierra Instruments.

In applications where frequent wash-down / hose-down is required, such as food and beverage, chemical processing, pharmaceutical and biotech, Max-Trak™ outperforms the competition as it conforms to the rigorous requirements of NEMA 6 and IP67.

Excellent accuracy and reliability coupled with unsurpassed instrument stability result from a patented, inherently linear design, advanced platinum sensor technology and a valve that is strong and forgiving of variations in process conditions.

Max-Trak™ measures and controls gas mass flow from 10 to 1000 SLPM, with lower flows (to 2 SLPM) and higher flows available upon request. Based upon Sierra's successful Smart-Trak® line of digital instruments, Max-Trak™ also offers Dial-A-Gas® multi-gas capability, both analog and digital communication and a wide variety of field adjustable parameters.

Max-Trak™ delivers the performance, flexibility and value you expect from Sierra Instruments.



The information contained herein is subject to change without notice.

Performance Specifications

Accuracy

Standard: +/- 1.0% of full scale including linearity at operating conditions
(+/- 2.0% of full scale for 180M from 201 to 300 SLPM)
High Accuracy Calibration: +/-0.7% of reading + 0.3% of full scale at calibration conditions

Dial-A-Gas

+/- 1.0% of full scale in all 10 standard gases

Repeatability

+/- 0.2% of full scale

Temperature Coefficient

+/- 0.025% of full scale per °F (0.05% of full scale per °C), or better

Pressure Coefficient

+/- 0.01% of full scale per psi (0.15% of full scale per bar), or better

Response Time

300 millisecond time constant; 2 seconds typical to within +/-2% of final value (includes settling time). Faster or slower available upon request.

Operating Specifications

Gases

All clean and dry gases including corrosives; specify when ordering

The following 10 gases make up the Dial-A-Gas feature of every Max-Trak instrument; up to 9 alternate gases may be substituted.

TABLE 1: DIAL-A-GAS

Flow Rate (slpm)	Maximum Flow Rate Standard Size(slpM)	Maximum Flow Rate High Flow Size (slpm)
Air	300	1000
Aragon	435	1450
CO ₂	220	740
CO	302	1000
Methane	227	720
Helium	420	1454
Hydrogen	300	1000
Oxygen	300	1000
Nitrogen	300	1000
Nitrous Oxide (N ₂ O)	215	710



Mass Flow Rates

180M Standard Size: 0-10 to 0-300 SLPM full scale (as low as 0-2 SLPM and as high as 0-400 SLPM available upon request)

180H High Flow Size: 0-100 to 0-1000 SLPM full scale

Flow range specified is for an equivalent flow of nitrogen at 760 mm Hg and 21°C (70°F); other ranges in other units are available (e.g., NLPM, SCFH, NM³/H, kg/H)

Gas Pressure

500 psig (34.5 barg) maximum, burst tested to 750 psig (52 barg)

Operating Specifications (Continued)

Gas & Ambient Temperature

Gas: 32°F to 122°F (0°C to 50°C)

Ambient: -5 to 122°F (-20 to 50°C)

Leak Integrity

5 X 10⁻⁹ atm. cc/sec of helium maximum

Power Requirements (ripple should not exceed 100 mV peak-to-peak)

For All Mass Flow Meters: 15-24 VDC +/- 10%, (130 mA, regulated).

For Mass Flow Controllers:

C180M: 24 VDC +/- 10%, (700 mA, regulated)

C180H: 24 VDC +/- 10%, (1260 mA, regulated)

Control Range For Controllers

2 to 100% of full scale flow; automatic shut-off at 1.9%

Output Signal

Analog:

Linear 4 to 20 mA, 500 ohms maximum loop resistance and one of the following (user selectable):

Linear 0 to 5 VDC, 1000 ohms minimum load resistance

Linear 0 to 10 VDC, 1000 ohms minimum load resistance

Linear 1 to 5 VDC, 1000 ohms minimum load resistance

Digital:

RS-232

Remote Pilot Module Display optional

Command Signal

Analog (choice of one, user selectable):

Linear 4-20 mA

Linear 0-5 VDC

Linear 0-10 VDC

Linear 1-5 VDC

Digital:

RS-232

Pilot Module Display or RS-485 optional

Physical Specifications

Wetted Material

316 stainless steel; 416 stainless steel; Viton® "O"-rings and valve seat standard

Other elastomers are available (consult factory).

Operating Specifications

Pressure Drop Across a Meter

Pressure must be above the values in the table below. Note that pressure increases with flow rate.

MINIMUM PRESSURE DROP FOR AIR IN PSI (MBAR), METERS			
Flow Rate (slpm)	Standard Size (M180M) 3/8 or 1/2 inch fittings	High Flow Size Small Bore (M180H) (std up to 500 slpm) 1/2 comp fittings	High flow Size Large Bore (M180H1, H2) (std 501-1000 slpm) 3/4 comp fittings
10	0.5 (34)	NA	N/A
20	0.5 (34)	NA	N/A
30	0.5 (34)	NA	N/A
40	0.5 (34)	NA	N/A
50	0.5 (34)	NA	N/A
100	1.0 (68)	1.0 (68)	0.5 (34)
150	2.0 (136)	1.2 (81.6)	0.5 (34)
200	5.5 (374)	1.5 (102)	0.5 (34)
250	N/A	1.8 (122.4)	0.5 (34)
300	N/A	2 (136)	0.6 (408)
350	N/A	2.5 (170)	0.7 (476)
400	N/A	3 (204)	0.9 (612)
450	N/A	3.5 (238)	1.1 (748)
500	N/A	4 (272)	1.3 (884)
750	N/A	N/A	3.0 (204)
1000	N/A	N/A	5.0 (340)

Differential Pressure Requirement for Controllers (lower or higher available upon request)

Optimum: 30 to 60 psi (2 to 4 bar)

Minimum: See chart below. Note that required pressure increases with flow rate.

MINIMUM DIFFERENTIAL PRESSURE FOR AIR IN PSI (MBAR), CONTROLLERS			
Flow Rate (slpm)	Standard Size (C180M) 3/8 or 1/2 inch fittings	High Flow Size Small Bore (C180) (std up to 500 slpm) 1/2 comp fittings	High flow Size Large Bore (C180)H1, H2 (std 501-1000 slpm) 3/4 comp fittings
10	N/A	NA	N/A
20	1 (68)	NA	N/A
30	1.2 (82)	NA	N/A
40	1.6 (110)	NA	N/A
50	2 (136)	NA	N/A
100	5 (340)	1.5 (102)	1.0 (68)
150	10 (680)	2 (136)	1.0 (68)
200	15 (1020)	4.5 (306)	1.0 (68)
250	20 (1360)	5.5 (374)	1.5 (102)
300	25 (1700)	6.5 (442)	2.0 (136)
350	N/A	8.5 (578)	3.0 (204)
400	N/A	10.5 (714)	4.0 (272)
450	N/A	13 (884)	5.0 (340)
500	N/A	15 (1020)	6.0 (408)
750	N/A	N/A	15 (1020)
1000	N/A	N/A	20 (1360)

Physical Dimensions

All dimensions are in inches with mm in brackets. Certified drawings are available on request.

M180M, M1 and C180M, M1 Front View

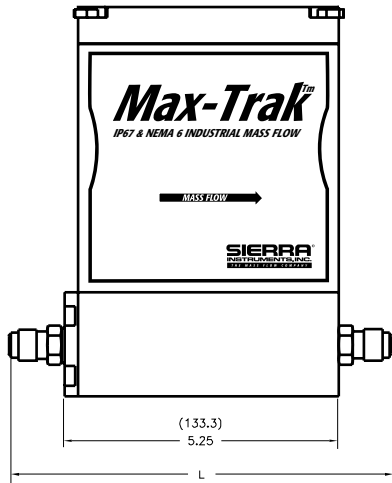

M180M, M1 and C180M, M1 Side View

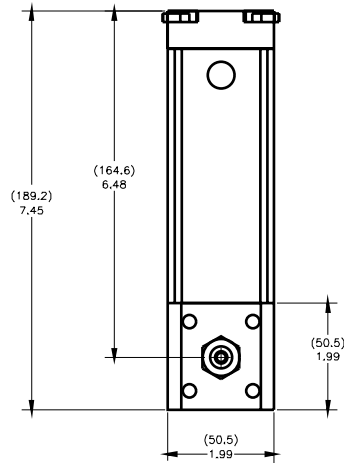

M180M, M1 and C180M, M1 Bottom View

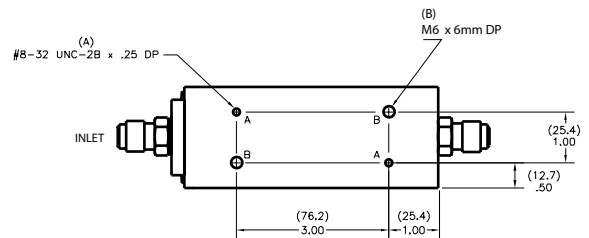

Dimension L

Fittings	Length with fittings in inches (mm)				
	C180M/M180M	M180H	M180H1, H2	C180H	C180H1, H2
1/8 compression	NA	NA	NA	NA	NA
1/4 compression	7.27 (186)	NA	NA	NA	NA
3/8 compression	7.39 (189)	NA	NA	NA	NA
1/2 compression	7.55 (194)	8.92 (229)	NA	10.37 (266)	NA
1/4 VCO	6.81 (175)	NA	NA	NA	NA
1/2 VCO	7.25 (186)	8.56 (220)	NA	10.01 (267)	NA
3/4 VCO	NA	NA	8.78 (225)	NA	11.28 (289)
1/4 VCR	7.13 (183)	NA	NA	NA	NA
1/2 VCR	7.43 (191)	9.00 (231)	NA	10.45 (268)	NA
6 mm compression	7.29 (187)	NA	NA	NA	NA
10 mm compression	7.45 (191)	NA	NA	NA	NA
12 mm compression	7.63 (196)	8.90 (228)	NA	10.35 (265)	NA
1/4 FNPT	7.10 (182)	NA	NA	NA	NA
3/8 FNPT	7.25 (186)	NA	NA	NA	NA
1/2 FNPT	NA	9.14 (234)	NA	10.59 (272)	NA
3/4 FNPT	NA	NA	9.30 (238)	NA	11.30 (290)
3/4 compression	NA	9.24 (237)	9.18 (235)	10.69 (274)	11.68 (300)
1 inch compression	NA	NA	9.52 (244)	NA	12.02 (308)

Physical Dimensions

All dimensions are in inches with mm in brackets. Certified drawings are available on request.

M180H, H1, H2 Front View

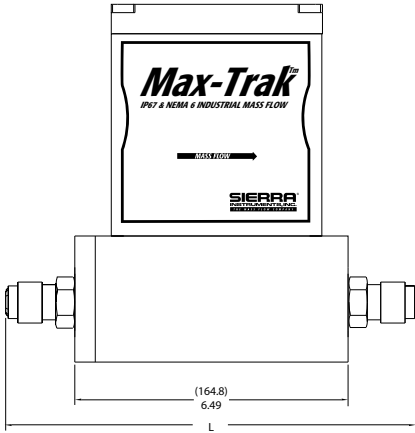

M180H, H1, H2 Side View

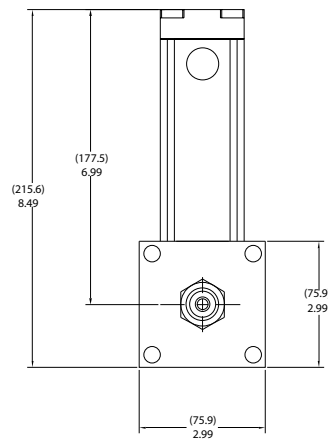

M180H, H1, H2 Bottom View

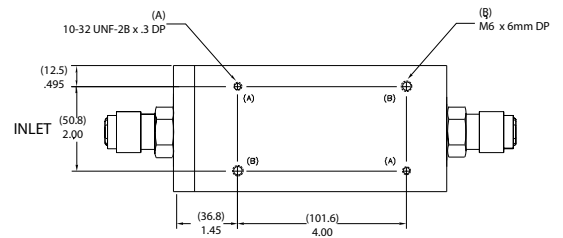

C180H, H1, H2 Front View

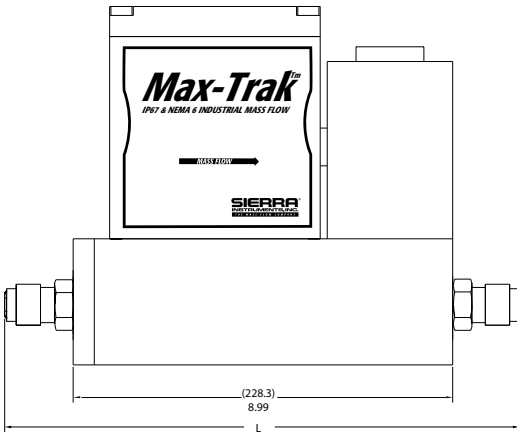

C180H, H1, H2 Side View

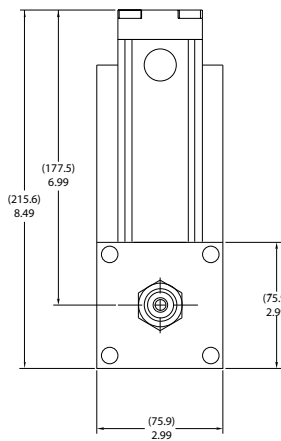

C180H, H1, H2 Bottom View

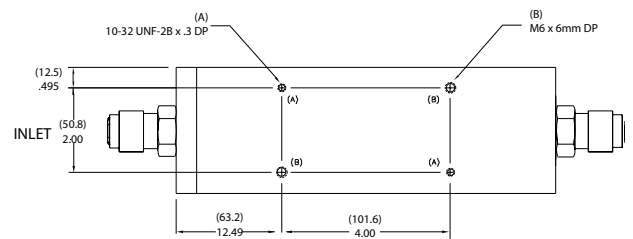



Micro-Trak™ Model 101 Ultra Low Flow Mass Flow Meters & Controllers

Specifically designed for flow ranges under 4 sccm (smlm) with a minimum controllable mass flow rate of 0.1 sccm (smlm). Also get digital high performance, stainless steel construction with Dial-A-Gas/E Technology & computer control.



Smart-Trak® Model 100 Mass Flow Meters & Controllers

Digital high performance, stainless steel with Dial-A-Gas/E Technology & computer control. Flow ranges from 0 to 15 sccm to 0 to 1000 slpm.



Max-Trak® Model 180 Industrial Mass Flow Meters & Controllers + Flanges

Industry's only NEMA 6/IP67 truly industrial MFC; Available as heavy industrial flanged version; Accuracy of +/- 1% of Full Scale and flow ranges from 0 to 10 SLPM to 0 to 1000 SLPM





SIERRA INSTRUMENTS, NORTH AMERICA • 5 Harris Court, Building L • Monterey, California • (800) 866-0200 • (831) 373-0200 • Fax (831) 373-4402 • www.sierrainstruments.com

SIERRA INSTRUMENTS, EUROPE • Bijlmansweid 2 • 1934RE Egmond aan den Hoef • The Netherlands • +31 72 5071400 • Fax: +31 72 5071401

SIERRA INSTRUMENTS, ASIA • Rm.618, Tomson Centre, Bldg. A • 188 Zhang Yang Road • Pu Dong New District • Shanghai, P.R. China 200122 • +8621 5879 8522 • Fax: +8621 5879 8586