

Wind Speed and Direction Sensors

03001 Wind Sentry Anemometer/Vane & 03101 Wind Sentry Anemometer

R. M. Young's Wind Sentry Anemometer and Vane accurately measure wind speed and direction. These sensors interface directly with Campbell dataloggers; no signal conditioning is required. The Wind Sentry is compatible with all of our contemporary dataloggers and many of our retired dataloggers (e.g., 21X, CR23X).

The cup anemometer measures wind speed. Rotation of its cup wheel produces an ac sine wave that is directly proportional to wind speed. The frequency of the ac signal is measured by a datalogger pulse count channel, then converted to engineering units (mph, m/s, knots). The Campbell Scientific version uses shielded bearings which lowers the anemometer's threshold.

Wind direction is sensed by a potentiometer. With the precision excitation voltage from the datalogger applied to the potentiometer element, the output signal is an analog voltage that is directly proportional to azimuth of the wind direction.

An ideal application for the Wind Sentry is Wind Profile Studies. For this application, the LLAC4 4-channel Low Level AC Conversion Module can be used to increase the number of Wind Sentrys measured by one datalogger. The LLAC4 allows datalogger control ports to read the anemometer's ac signals instead of using pulse channels. Dataloggers compatible with the LLAC4 are the CR200-series (ac signal \leq kHz only), CR800, CR1000, CR3000, and CR5000.

Ordering Information

Wind Sentry Options

- 03001-L_ Wind Sentry Set; enter wind speed lead length, in feet, after the L, then enter wind direction lead length
- 03101-L_ Wind Sentry Anemometer; enter lead length, in feet, after the L.

Mounts

- 1049 $\frac{3}{4}$ " x 1" NU-RAIL Fitting for attaching the Wind Sentry to a horizontal crossarm, such as a CM202, CM204, or CM206.
- CM220 Right Angle Mounting Bracket for attaching the Wind Sentry to a horizontal crossarm, such as a CM202, CM204, or CM206.
- CM215 Sensor Mounting Kit for attaching the Wind Sentry to the top of a CM110, CM115, or CM120 aluminum tripod.



The 03001 is secured to one end of the CM206 Crossarm with the CM220 Right Angle Bracket.

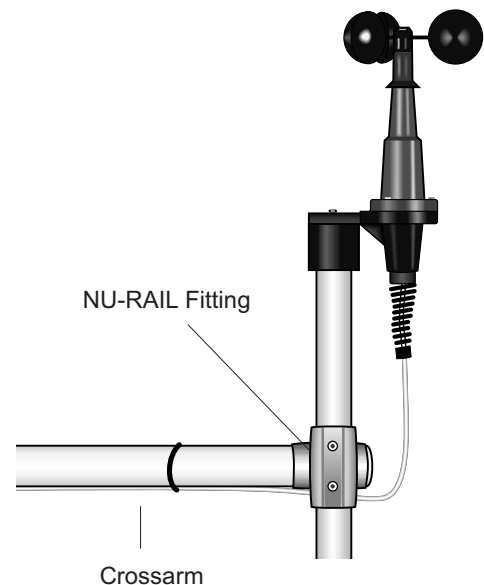

When purchased separately, the Wind Sentry Anemometer is supplied with a galvanized 10" x 3/4" -diameter threaded pipe, which mounts to a crossarm via the NU-RAIL fitting or CM220 Mount. Alternately it can mount to an aluminum tripod via the CM215.



CAMPBELL SCIENTIFIC, INC.

815 W. 1800 N. • Logan, Utah 84321-1784 • (435) 753-2342 • FAX (435) 750-9540 • www.campbellsci.com

Recommended Lead Lengths

These lead lengths assume the sensor is mounted atop the tripod/tower via a CM202 crossarm.

CM6	CM10	CM110	CM115	CM120	UT10	UT20	UT30
10'	13'	13'	19'	24'	13'	24'	34'

Wind Speed (Anemometer) Specifications

Range:	0 to 50 m s ⁻¹ (112 mph), gust survival 60 m s ⁻¹ (134 mph)
Sensor:	12 cm diameter cup wheel assembly, 40 mm diameter hemispherical cups
Accuracy:	±0.5 m s ⁻¹ (1.1 mph)
Turning Factor:	75 cm (2.5 ft)
Distance Constant (63% recovery):	2.3 m (7.5 ft)
Threshold:	0.5 m s ⁻¹ (1.1 mph)
Transducer:	Stationary coil, 1350 ohm nominal resistance
Transducer Output:	AC sine wave signal induced by rotating magnet on cup wheel shaft 100 mV peak-to-peak at 60 rpm; 6 V peak-to-peak at 3600 rpm
Output Frequency:	1 cycle per cup wheel revolution; 0.75 m s ⁻¹ per Hz
Cup Wheel Diameter:	12 cm (4.7 in)
Weight:	113 g (4 oz)

Wind Direction (Vane) Specifications

Range:	360° mechanical, 355° electrical (5° open)
Sensor:	Balanced vane, 16 cm turning radius
Accuracy:	±5°
Damping Ratio:	0.2
Delay Distance (50% recovery):	0.5 m (1.6 ft)
Threshold	0.8 m s ⁻¹ (1.8 mph) at 10° displacement 1.8 m s ⁻¹ (4 mph) at 5° displacement
Transducer:	Precision conductive plastic potentiometer; 10 kohm resistance; 0.5% linearity; life expectancy 20 million revolutions. Rated 1 watt at 40°C, 0 watts at 125°C.
Transducer Output:	Analog dc voltage proportional to wind direction angle with regulated excitation voltage supplied by the datalogger
Vane Length:	22 cm (8.7 in)
Vane Weight:	170 g (6 oz)

Wind Sentry Assembly Specifications

Operating Temperature:	-50° to +50°C assuming non-riming conditions
Overall Height:	32 cm (12.6 in)
Crossarm Length:	40 cm (15.7 in) between instruments (center-to-center)
Mounting Diameter:	26.7 mm (1.05 in), mounts on standard 3/4 in. pipe

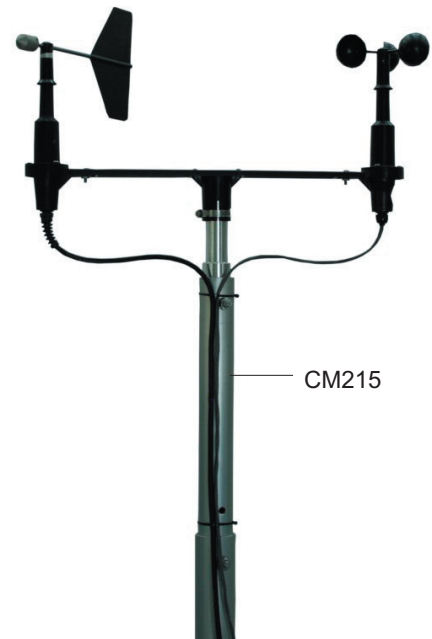

The Wind Sentry can sit atop an aluminum tripod via the CM215.



CAMPBELL SCIENTIFIC, INC.

815 West 1800 North • Logan, Utah 84321-1784 • (435) 753-2342 • Fax (435) 750-9540
Offices also located in: Australia • Brazil • Canada • England • France • Germany • South Africa • Spain

Copyright © 1994, 2006
Campbell Scientific, Inc.
Printed May 2006