

Wind Speed and Direction Sensors

05103 Wind Monitor, 05106 Wind Monitor-MA, 05305 Wind Monitor-AQ

RM Young's Wind Monitors are light-weight instruments that measure wind speed and direction. Their design emphasizes simplicity and lightweight construction. The Wind Monitors are made out of rigid UV-stabilized thermoplastic with stainless steel and anodized aluminum fittings. The thermoplastic material resists corrosion from sea air environments and atmospheric pollutants. The Wind Monitors use stainless steel precision-grade ball bearings for the propeller shaft and vertical shaft bearings. Cabled for use with our dataloggers, the Wind Monitors are compatible with all of our contemporary dataloggers and many of our retired dataloggers (e.g., 21X, CR23X).

Wind Speed

The wind speed sensor for all the Wind Monitors is a helicoid-shaped, four-blade propeller. Rotation of the propeller produces an ac sine wave that has a frequency directly proportional to wind speed. The ac signal is induced in a transducer coil by a six-pole magnet mounted on the propeller shaft. The coil resides on the non-rotating central portion of the main mounting assembly, eliminating the need for slip rings and brushes.

Wind Direction

All of the Wind Monitors use a potentiometer to measure wind direction. The datalogger applies a known precision excitation voltage to the potentiometer element. The output signal is an analog voltage directly proportional to the azimuth angle.

05103 Wind Monitor

The 05103 Wind Monitor is a sturdy instrument for measuring wind speed and direction in harsh environments. Its simplicity and corrosion-resistant construction make it ideal for a wide range of wind measuring applications.

05106 Wind Monitor-MA

The 05106 Wind Monitor-MA is a robust instrument designed for offshore and marine applications. It features waterproof bearing lubricant and a sealed, heavy-duty cable pigtail instead of the standard junction box.

05305 Wind Monitor-AQ

The 05305 Wind Monitor-AQ is a high performance wind speed and direction sensor designed specifically for air quality measurements. It provides a lower starting threshold, faster response, and higher accuracy than the other wind monitors. However, to achieve the superior performance, the 05305 is less ruggedly constructed. The Wind Monitor-AQ meets or exceeds the requirements published by the following regulatory agencies:

- U.S. Environmental Protection Agency—Ambient Monitoring Guidelines for Prevention of Significant Deterioration (PSD) and On-Site Meteorological Instrumentation Requirements to Characterize Diffusion from Point Sources
- U.S. Nuclear Regulatory Agency—NRC Regulatory Guide 1.23 Meteorological Programs in Support of Nuclear Power Plants
- American Nuclear Society—Standard for Determining Meteorological Information at Nuclear Power Plants

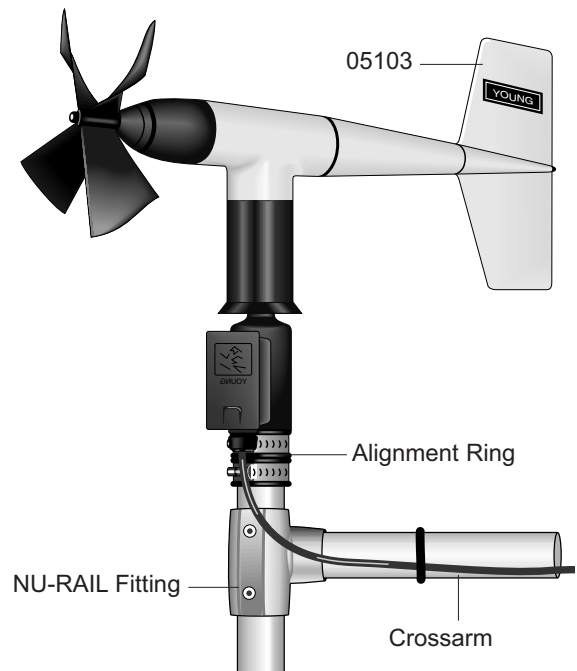

CAMPBELL SCIENTIFIC, INC.

815 W. 1800 N. • Logan, Utah 84321-1784 • (435) 753-2342 • FAX (435) 750-9540 • www.campbellsci.com

Mounting

The Wind Monitors can be attached to a CM202, CM204, or CM206 crossarm via a NU-RAIL fitting or CM220 Right Angle Mounting Bracket. Alternately, the Wind Monitors can be attached to the top of our aluminum tripods via the CM215 Sensor Mounting Kit.

Wind Profile Studies

Wind profile studies measure many wind sensors. For these applications, the LLAC4 4-Channel Low Level AC Conversion Module can be used to increase the number of Wind Monitors measured by one datalogger. The LLAC4 allows datalogger control ports to read the wind speed sensor's ac signals instead of using pulse channels. Dataloggers compatible with the LLAC4 are the CR200-series (ac signal ≤ 1 kHz only), CR800, CR1000, CR3000, and CR5000.



The LLAC4 is often used to measure up to four Wind Monitors, and is especially useful for wind profiling applications.



The CM215 allows the Wind Monitor to sit atop an aluminum tripod.

Ordering Information

Wind Monitors

- 05103-L_ Wind Monitor with user-specified lead length. Specify the lead length, in feet, after the L. For example, 05103-L13 order a 13 ft lead length.
- 05106-L_ Wind Monitor-MA for marine applications with user-specified lead length. Specify the lead length, in feet, after the L. For example, 05106-MA-L13 order a 13 ft lead length.
- 05305-L_ Wind Monitor-AQ for air quality applications with user-specified lead length. Specify the lead length, in feet, after the L. For example, 05305-L13 order a 13 ft lead length.

Mounts

- 17953 1" x 1" NU-RAIL Fitting for attaching the Wind Monitor to a horizontal crossarm, such as a CM202, CM204, or CM206 crossarm.
- CM220 Right Angle Mounting Bracket for attaching the Wind Monitor to a horizontal crossarm, such as a CM202, CM204, or CM206.
- CM215 Sensor Mounting Kit for attaching sensor to the top of a CM110, CM115, or CM120 aluminum tripod.

Wind Profile Accessory

- LLAC4 4-Channel Low-Level AC Conversion Module

Recommended Lead Lengths

These lead lengths assume the sensor is mounted atop the tripod/tower via an 019ALU or CM202 crossarm.

CM6	CM10	CM110	CM115	CM120	UT10	UT20	UT30
10'	13'	13'	19'	24'	13'	24'	34'

Specifications

	05103 and 05106	05305
Wind Speed		
Range:	0-134 mph (0-60 m s ⁻¹)	0-90 mph (0-40 m s ⁻¹)
Accuracy:	±0.6 mph (±0.3 m s ⁻¹)	±0.4 mph (±0.2 m s ⁻¹)
Starting threshold:	2.2 mph (1.0 m s ⁻¹) 05103; 2.4 mph (1.1 m s ⁻¹) 05106	0.9 mph (0.4 m s ⁻¹)
Gust survival:	220 mph (100 m s ⁻¹)	100 mph (45 m s ⁻¹)
Distance constant (63% recovery):	8.9 ft (2.7 m)	6.9 ft (2.1 m)
Output:	ac voltage (3 pulses per revolution). 1800 rpm (90 Hz) = 19.7 mph (8.8 m s ⁻¹)	ac voltage (3 pulses per revolution) 1800 rpm (90 Hz) = 20.6 mph (9.2 m s ⁻¹)
Wind Direction		
Range:	0-360° mechanical, 355° electrical (5° open)	Same
Accuracy:	±3°	±3°
Starting threshold at 10° displacement:	2.2 mph (1.1 m s ⁻¹)	1.0 mph (0.5 m s ⁻¹)
Delay distance (50% recovery):	4.3 ft (1.3 m)	3.9 ft (1.2 m)
Damping ratio:	0.25	0.45
Damped natural wavelength:	24.3 ft (7.4 m)	16.1 ft (4.9 m)
Undamped natural wavelength:	23.6 ft (7.2 m)	14.4 ft (4.4 m)
Output:	Analog dc voltage from potentiometer - resistance 10 kΩ, linearity 0.25%, life expectancy 50 million revolutions.	Same
Power	Switched excitation voltage supplied by the datalogger.	Same

Specifications (continued)

Physical

	<u>05103 and 05106</u>	<u>05305</u>
Operating Temperature	-50° to +50°C, assuming non-riming conditions	-50° to +50°C, assuming non-riming conditions

Dimensions

Overall:	14.6" H x 21.7" L (37 cm x 55 cm)	15.0" H x 25.6" L (38 cm x 65 cm)
Main housing Diameter:	2.0" (5 cm)	Same
Propeller Diameter:	7.1" (18 cm)	7.9" (20 cm)
Mounting Pipe:	1.34" (34 mm) OD; standard 1.0" IPS schedule 40	Same
Weight (shipping approx.)	3.2 lbs (5.5 lbs); 1.5 kg (2.3 kg)	2.5 lbs (5.5 lbs); 1.1 kg (2.3 kg)

Manufactured by RM Young (Traverse City, MI) and cabled by Campbell Scientific for use with our dataloggers.



CAMPBELL SCIENTIFIC, INC.

815 West 1800 North • Logan, Utah 84321-1784 • (435) 753-2342 • Fax (435) 750-9540
Offices also located in: Australia • Brazil • Canada • England • France • Germany • South Africa • Spain

Copyright © 1991, 2006
Campbell Scientific, Inc.
Printed May 2006