

PathWay® Model 7283 4-Channel RS530 A/B Switch with DB25 Interface, Dual Serial Remote Control Ports and Dual Power Supply Ports

- **Highest Reliability achieved through Redundant Remote Control and Redundant Power Supplies**

INTRODUCTION

The Model 7283 4-Channel A/B Switch, DB25 Interface with **Dual Serial Remote and Power Ports** allows the user the capability of sharing a single DB25 interface device connected to the COMMON port among two other devices connected to the "A" and "B" ports for four separate channels. The system affords local and remote access functionality. Remote access can be accomplished by RS232 commands sent via the Remote Serial Ports. Users can remotely monitor status and control switch functions.

FEATURES:

- The switch ports are transparent to all data.
- All channels are switched simultaneously.
- All switched signals are passed via copper contact relays that maintain their position continuity even in the event of a power loss.
- Connecting the Serial Remote Port 1 of each Model 7283 unit in a multi-drop format will allow a command sent by the first serial control device to be heard by all connected Model 7283 units. Similarly, connecting the Serial Remote Port 2 of each Model 7283 unit allows a command sent from the second control device to be received by all connected Model 7283 units.
- Each Model 7283 is addressable. Therefore, each Model 7283 unit can be switched individually or all connected Model 7283 units can be switched simultaneously.
- Remote control commands include: changing the Model 7283 position, querying the Model 7283 position, and lock/unlock front panel push button control of the Model 7283.
- All A, B, and Common ports on the M7283 are DB25 female connectors.
- All (25) signal lines of the DB25 RS530 interface connectors are supported.
- There are four channels, each containing an "A", "B" and "Common" port for a total of 12 switch ports on the rear panel.
- LEDs on the front panel display the switch position (A/B), front panel lockout status, and power status.
- **Dual power supply ports** allow each of two separate external power supplies to be connected to the unit for redundancy. Internal circuitry will automatically regulate which supply source powers the unit. If a supply is removed, the supply remaining will power the unit.
- Unit mounts in a standard 2U high, 19-inch wide equipment rack.
- **Multiple Switches can be cascaded together for simultaneous switching. (See illustration on page 2.)**
- The Model 7283 can also be utilized to switch RS232 interface.

★ **Municipalities, schools, government: This product is on GSA Schedule!**



MODEL 7283 APPLICATION

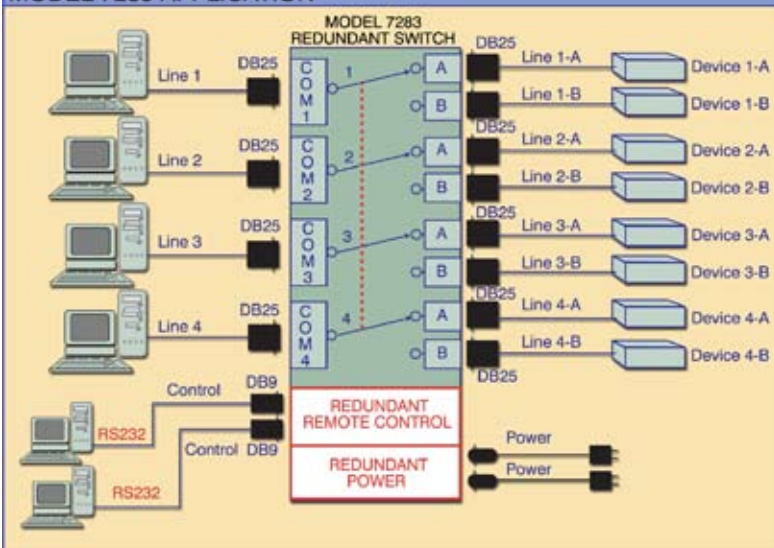

SPECIFICATIONS:

CONNECTORS: (12) DB25(F) Connectors on rear panel labeled A1, B1, COM1, A2, B2, COM2, A3, B3, COM3, A4, B4, COM4.

FRONT PANEL CONTROLS: Manual pushbutton, switches all four channels simultaneously.

REMOTE CONTROLS: (2) DB9(F) Connectors on rear panel accept multidrop RS232.

FRONT PANEL DISPLAY: (2) LEDs A, B, indicate switch status and power presence.

POWER: (2) Power Jacks on rear panel accept power from (2) CE and UL listed table mount power modules, 100VAC/240VAC, 50/60Hz. (included with the unit) (Cat. No. 517277)

DIMENSIONS: 19.0"W x 3.5"H x 8.0"D. (48.3 x 8.9 x 20.3 cm)

WEIGHT: Approx. 7.5 lbs. (3.4 Kg)

Cascade Cables for Use with Model 7283

Catalog No.	Description	Price (USD)
516164-003'	DB9 Serial Y-Cable 2(M) to 1(F), 3 Foot Legs (w/thumbscrews)	\$15.00
990127-010'	DB9(F) to DB9(F), 10 feet	\$15.00
510240-006'	DB9(F) to DB9(M), 6 feet (w/thumbscrews)	\$10.00

