

Model 7246-ESL Dual Channel RS530 Switch and RJ45 Secure/Non-Secure Switch w/Cutoff

The Model 7246-ESL Dual Channel RS530 and RJ45 Secure/Non-Secure Switch with Cutoff provides two channel switching in a low profile, 19-inch 1U rack unit. The unit's dimensions are 19" W x 1.75" H x 8" D.

Channel One allows the user the capability of sharing a single DB25(M) interface device connected to the "COMMON" port among two other DB25(F) devices connected to the "SECURE" AND "NON-SECURE" DB25 ports.

Channel Two allows the user the capability of sharing an RJ45 device connected to the "COMMON" port among two other RJ45 devices connected to the "SECURE" and "NON-SECURE" RJ45 ports. Both channels allow the user to set the switches to the "CUTOFF" position, which stops any and all data throughput for the switch.

The switch may be controlled locally by manually operating the front panel pushbuttons or remotely from the DB9 Control port located on the rear of the unit using either contact closures or an RS232 command interface. The front panel LED displays indicate the respective switch position and unit power status.

All ports ("SECURE", "NON-SECURE", and "COMMON") for each switch are transparent to all data going through that switch. If power to the Model 7246-ESL is removed, both switches will automatically move to the "CUTOFF" position. When it is restored, each switch will move to the programmed default position.



Features:

- Both Channels offer SECURE / NON-SECURE / CUTOFF switch positions with remote control.
- **Channel One** is RS530 compatible. All 25 pins switched.
- **Channel Two** is RJ45 compatible. All 8 pins switched.
- Remote switching via contact closure of specified pins of DB9 Remote port on rear panel or remotely controlled using an RS232 terminal interface.
- Local switching via two front panel pushbuttons.
- Local switch change sends ASCII text over the RS232 interface to notify the user of the new switch position.
- All ports are located on the rear panel.
- Status LED's on the front panel indicate the switch position & power status.
- Either channel can be set to "CUTOFF" position, which stops any and all data throughput for the switch.
- Unit mounts in standard 19" equipment rack, 1U space.

SPECIFICATIONS:

CHANNEL 1 PORT CONNECTORS: (3) DB25 (F/F/M) connectors labeled SECURE, NON-SECURE and COMMON, respectively.

CHANNEL 2 PORT CONNECTORS: (2) RJ45(F) connectors labeled SECURE, NON-SECURE and COMMON.

FRONT PANEL CONTROLS: (2) Manual pushbuttons on front panel.

REMOTE CONTROL: DB9 female connector on rear panel accepts contact closure or RS232 serial data.

LOCAL DISPLAY: (6) LEDs on front panel display switch position and power presence.

POWER: 115 VAC, 60 Hz wall mount power supply.

DIMENSIONS: 1.75" H x 19.0" W x 8.0" D.

WEIGHT: 4.5 lbs.

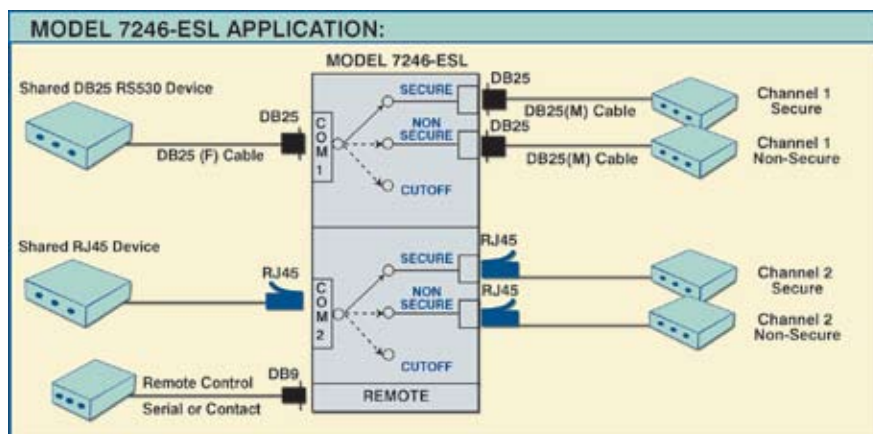

REMOTE CONTROL VIA CONTACT CLOSURE

DB9 PIN #	SIGNAL
1	CH1, Contact #1
4	CH1, Contact #2
6	CH1, Contact Ground
7	CH 2, Contact #1
8	CH 2, Contact #2
9	CH2, Contact Ground

REMOTE CONTROL VIA SERIAL DATA

DB9 PIN #	SIGNAL	DIRECTION
2	RD	Output
3	TD	Input
5	Signal Gnd	—