

CellMite® Model 4325B Intelligent Digital Signal Conditioner With TEDS-Tag™ Auto Identification

Features:

- Single Channel (Model 4325B)
- 2-pt mV/V Calibration
- 6-pt Linearization Calibration
- Scalable +/- 10V Analog Output
- 16-Bit Analog Output
- Direct to PC with RS232 Data
- 24 Bit Resolution
- Multiple Filter Selections
- Storage for Three Calibrated Transducers
- Precision Shunt
- Remote Sense Excitation
- Addressable for Serial Network
- Tare, Peak, Valley.
- Unit Support: In, Cm, mm, %, Lb, Kg, N, mV/V, User Defined.
- TEDS-Tag™ Auto Identification
- Power Supplies Internally Isolated
- Graphical User Interfaces (GUI) and Software Drivers sold separately. Select from:
 - CellView Lite GUI (Cat. No. 514569)
 - CellView Multi-Display GUI (Cat. No. 514424)
 - Software Drivers (Cat. No. 514864)

Ideally suited for in-situ transducer conditioning and distributed process measurements!

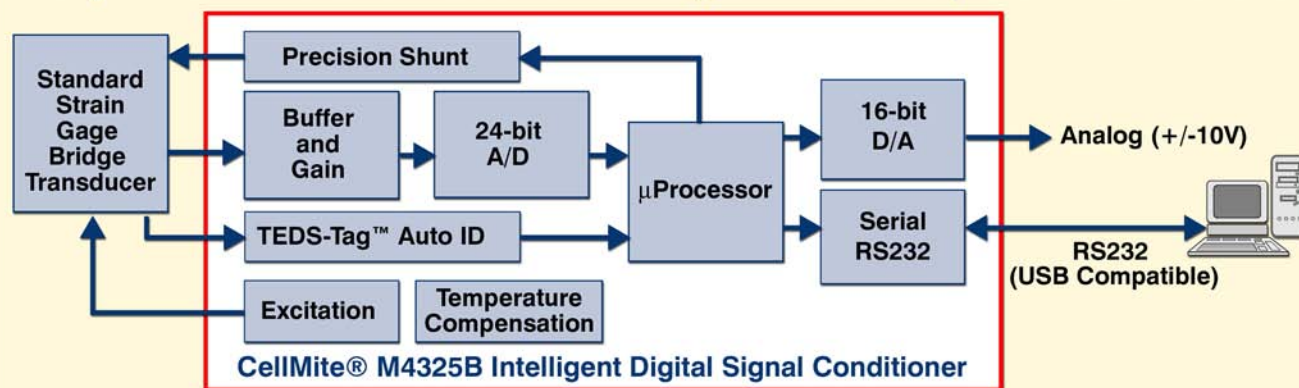

CellMite® is a compact digital signal conditioner that connects directly to a standard strain gage-based load cell, extensometer, or pressure sensor and simultaneously generates a serial digital output for connection to a PC as well as a +/- 10V analog output.

CellMite® compensates for transducer nonlinearities using its integrated 6-point calibration capability not found in standard signal conditioners. Its multi-drop RS232 serial port, unit addressing capabilities, and simple command set allow for connection of multiple units in a serial network configuration. The TEDS-Tag™ auto identification feature with integrated electronic tags allows the CellMite® to automatically select the correct sensor calibration and analog output for scaling for the connected transducer.

CellMite® features a nonvolatile memory for parameter and calibration storage, the ability to select between three transducers, multi-point and mV/V calibration, remote sense excitation, and a 24-bit internal resolution with 16-bit analog output.





Electro Standards Laboratories

ADVANCED SYSTEMS DESIGN & SERVICES



CellMite® Model 4325B Specifications

Excitation:

Voltage: 5 VDC. Nom. Load 350 w.

Operation:

Internal Resolution: 24-bit.
Input Range: +/-5.5 mV/V.
Conversion Rate: 60 per second.
Error: 0/01%, +/- 1 count.
Precision Shunt 60K.

Outputs:

Analog: 16-bit, Scalable, +/-10V.
Serial Data: Multi-drop RS-232.

Mechanical:

Size: 5.5" x 2.75" x 1.2".
Weight: 8.3 oz. (235g).

Power:

5 VDC, 150mA. (Included Adpater)
110/240VAC, 60/50 Hz.

Included Items:

DB9 Mating Connectors
Operational Manual on CD ROM.

CellView Lite GUI Software (Cat. No. 514569)

Features:

- Turnkey data acquisition system
- Save data, calibration, and sensor test information to Excel spreadsheets
- Guides user through sensor calibration
- Guides user through adding/removing networked CellMite® and CellMite® LVDT units.
- Ability to select any networked Model 4325B unit
- Ability to individually name Model 4325B units
- Tare and reset peak and valley for the sensor
- Save/Load the Model 4325B unit and sensor setup information
- Set output data with user defined 5th order polynomial function
- Setup a test to start and/or stop automatically
- Control Model 4325B solid state output relay switches
- User programmable analog output voltage range
- Units of In, Cm, mm, %, Lb, Kg, User Defined



CellView Multi-Display GUI Software (Cat. No. 514424)

Features:

- Turnkey simultaneous data acquisition system for networked CellMite® and CellMite® LVDT units
- Supports mix and match of CellMite® and CellMite® LVDT units on network
- Ability to define 8 simultaneous data displays from multiple channels on multiple units
- Save data, calibration, and sensor test information to Excel spreadsheets for all networked units
- Guide user through sensor calibrations
- Guides user through adding/removing networked CellMite® and CellMite® LVDT units
- Ability to select and name any networked units
- Tare and reset peak and valley for the sensors
- Save/Load units and sensor setup information
- Set output data with user defined 5th order polynomial function
- Setup a test to start and/or stop automatically with user selectable trigger events and delayed triggering
- Multi sample rate data acquisition via user definable data logging profile
- User programmable analog output voltage range for attached CellMite® and CellMite® LVDT units
- Units of In, Cm, mm, %, Lb, Kg, mV/V, and User Defined

