

CellMite® LVDT AC Excitation Dual Channel Embedded Digital Signal Conditioner Board

Features:

- Dual Channel (M4331-200)
- 2-pt mV/V Calibration
- 6-pt Linearization Calibration
- Scalable $\pm 10V$ Analog Output
- 16-bit Analog Output
- Direct to PC with RS232 Data
- 24 Bit Resolution
- Multiple Filter Selections
- Storage for Three Calibrated Transducers
- Selectable Sensor Gains
- Remote Sense Excitation
- Addressable for Serial Network
- Tare, Peak, Valley.
- Unit Support: In, Cm, mm, %, Lb, Kg, N, mV/V, User Defined.
- TEDS-Tag™ Auto Identification
- Power Supplies Internally Isolated
- Graphical User Interfaces (GUI) and Software Drivers sold separately. Select from:
 - CellView Lite GUI (Cat. No 514569)
 - CellView Multi-Display GUI (Cat No. 514424)
 - Software Drivers (Cat No. 514864)

The Model 4331-200 CellMite® LVDT embedded digital signal conditioner board from Electro Standards Laboratories connects directly to two standard AC LVDT (Linear Variable Differential Transformer) transducers and simultaneously generates a serial output for connection to a PC and a $\pm 10V$ analog output. The CellMite® LVDT embedded conditioning board can be operated with a computer or simply setup by a computer and then used as a stand-alone intelligent LVDT digital signal conditioner with an analog output.

The Model 4331-200 CellMite® LVDT has on board storage for up to three calibrated LVDTs, each with integrated 6-point calibration that can be used to linearize the LVDT outputs. Its multidrop RS232/RS485 serial port and simple command set allow for connection of multiple units in a serial network configuration. This compact unit is ideally suited for in-situ transducer conditioning and distributed process measurements. It provides OEM users and system integrators with an affordable and complete LVDT-to-PC solution.

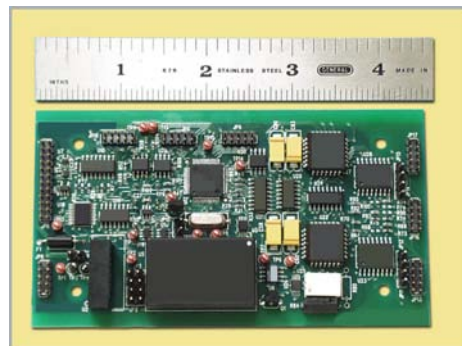

Model 4331-200 features include nonvolatile memory for parameter and calibration storage, the ability to select between 3 stored LVDT calibrations, and automatic LVDT identification using TEDS-Tag™ technology. Solid state relay switches, multi-point and mV/V calibration, and the ability to locate LVDT core null position are incorporated into the unit. Internal generation of precision sine wave AC excitation voltages, remote sense excitation, and 24-bit internal resolution with 16-bit analog output are also standard.

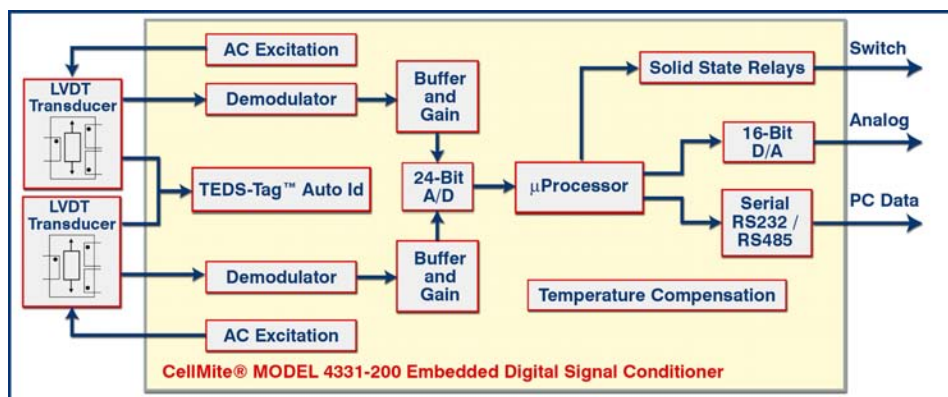



Electro Standards Laboratories

ADVANCED SYSTEMS DESIGN & SERVICES

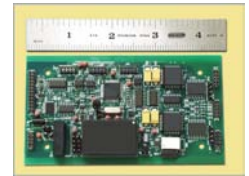

CellMite® Model 4331-200 Specifications:

Excitation:

Voltage: 3kHz, 3 Vrms (std)
Sensors: LVDT's, AC Bridges

Operation:

Internal Resolution: 24-bit.
Input Range: software adjustable from <10mV/V to> 100mV/V

Conversion Rate: 60/sec. single channel only
7.5/sec. dual channel

Error: 0.05%, ±1 count
Precision Shunt: 60Kw for bridge applications

Outputs:

Analog: 16-bit, Scalable, ±10V
Serial Data: Multi-drop RS232, RS485
Switch: Dual solid state relays

Power

Included Adapter: 5 VDC, 0.6A (std)
Optional: 110/240VAC, 60/50 Hz
12, 24, 48 VDC

Mechanical:

Size: 4.5" x 2.5" x 0.85"
Weight: 2 oz. (57 g)

CellView Lite GUI Software (Cat No. 514569)

Features:

- Turnkey data acquisition system
- Save data, calibration, and sensor test information to Excel spreadsheets
- Guides user through sensor calibration
- Guides user through adding/removing networked CellMite® and CellMite® LVDT units.
- Ability to select any networked M4331 unit
- Ability to individually name M4331 units
- Tare and reset peak and valley for the sensor
- Save/Load the M4331 unit and sensor setup information
- Set output data with user defined 5th order polynomial
- Setup a test to start and/or stop automatically
- Control M4331 solid state output relay switches
- User programmable analog output voltage range
- Units of In, Cm, mm, %, Lb, Kg, User Defined

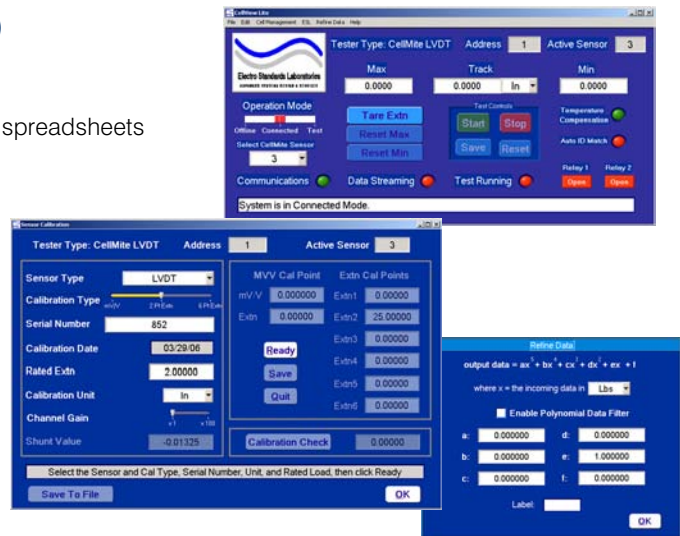

CellView Multi-Display GUI Software (Cat No. 514424)

Features:

- Turnkey simultaneous data acquisition system for networked CellMite® and CellMite® LVDT units
- Supports mix and match of CellMite® and CellMite® LVDT units on network
- Ability to define 8 simultaneous data displays from multiple channels on multiple units
- Save data, calibration, and sensor test information to Excel spreadsheets for all networked units
- Guide user through sensor calibrations
- Guides user through adding/removing networked CellMite® and CellMite® LVDT units
- Ability to select and name any networked units
- Tare and reset peak and valley for the sensors
- Save/Load units and sensor setup information
- Set output data with user defined 5th order polynomial function
- Setup a test to start and/or stop automatically with user selectable trigger events and delayed triggering
- Multi sample rate data acquisition via user definable data logging profile
- User programmable analog output voltage range for attached CellMite® and CellMite® LVDT units
- Units of In, Cm, mm, %, Lb, Kg, mV/V, and User Defined



36 Western Industrial Drive, Cranston, RI 02921
Tel: 401-943-1164 Fax: 401-946-5790

www.ElectroStandards.com
E-mail: eslab@ElectroStandards.com