

SIDE CLAMPS - CENTER MOUNT

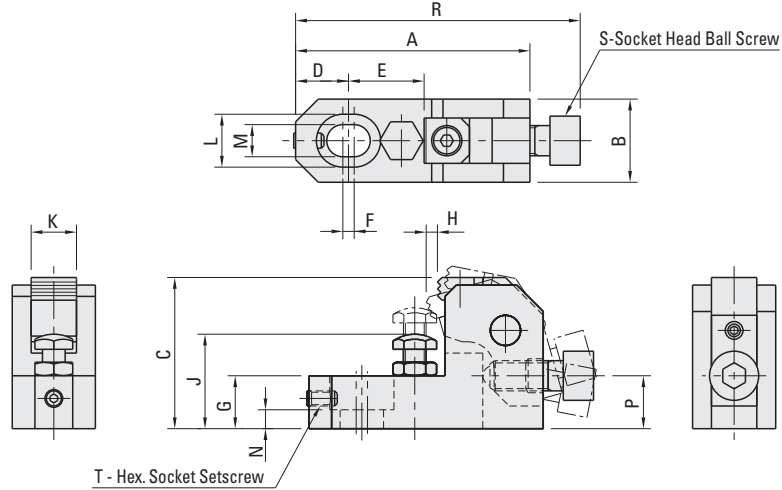

These side clamps utilize smaller clamping space which allows for greater machine clearance. Mounting screw and work support are under the work piece minimizing clamping space. Tightening the ball screw forces the clamp forward and downward against the work piece supports and stops. The hex socket set screw works to prevent the clamp from sliding back when clamping. The body is made from SAE-1045 alloy steel, heat treated. The arm is made from SAE-1045 alloy steel. The replaceable serrated jaw provides positive holding and is made from M-2 high speed steel, hardened to Rc 60/62. Parts have a black oxide finish.

Part#	A mm	B mm	C mm	D mm	E mm	F mm	G mm	H mm	J mm	K mm	L mm	M mm	N mm	P mm	R mm	S mm	T mm	Clamping Force lbs.	Screw Torque Ft. lbs.
CP100-08040	62	22	40	14	20	3	14	3.0	25-32	12	14	8.5	5	14.0	75.5	M8X1.25	M4X0.7	1348	11
CP100-10050	78	25	50	18	25	4	18	3.7	32-40	16	17.5	11.0	7	17.5	95.0	M10X1.5	M5X0.8	2248	22
CP100-12060	93	32	60	21	30	5	21	4.5	40-48	20	20	13.0	8	21.0	113.0	M12X1.75	M6X1	3821	47
CP100-16080	124	38	80	28	40	6	27	6.0	48-63	25	26	17.0	10	28.0	151.0	M16X2	M8X1.25	5620	95

SIDE CLAMPS - SINGLE JAW

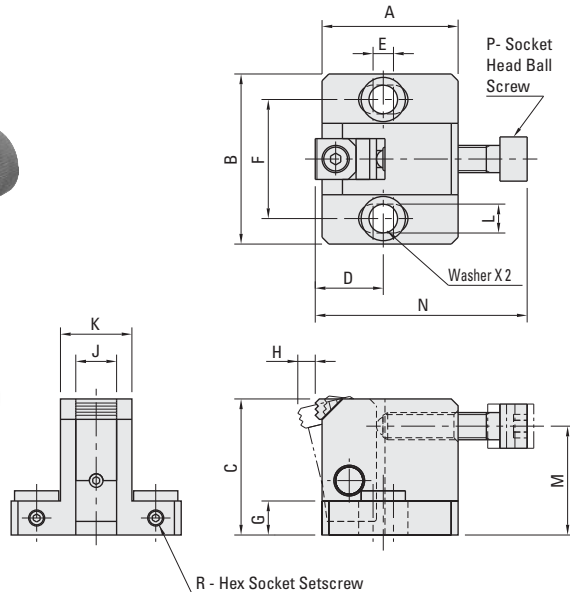

How To Use and Install

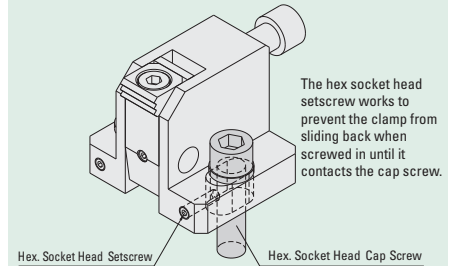

These side clamps utilize smaller clamping space which allows clamping larger work pieces. Tightening the ball screw forces the clamp forward and downward against the work piece supports and stops. The hex socket set screw works to prevent the clamp from sliding back when clamping. Two flat washers included. The body is made from SAE-1045 alloy steel. The arm is made from SAE-1045 alloy steel, heat treated. The replaceable serrated jaw provides positive holding and is made from M-2 high speed steel, hardened to Rc 60/62. Parts have a black oxide finish.

Part#	A mm	B mm	C mm	D mm	E mm	F mm	G mm	H mm	J mm	K mm	L mm	M mm	N mm	P mm	R mm	Clamping Force lbs.	Screw Torque Ft. lbs.
CP101-08040	40	50	40	20	6	35	10	5.3	12	21	8.5	32	62.5	M8X1.25	M4X0.7	2742	18
CP101-10050	50	65	50	25	8	45	12	7.1	16	27	11.0	40	74.0	M10X1.5	M4X0.7	4046	36
CP101-12060	60	70	60	30	10	50	15	8.0	20	31	13.0	48	91.0	M12X1.75	M5X0.8	5620	66
CP101-16080	80	90	80	40	15	65	20	10.2	25	39	17.0	64	115.0	M16X2	M6X1	10340	147