

COMPACT SIDE CLAMPS - LOW PROFILE

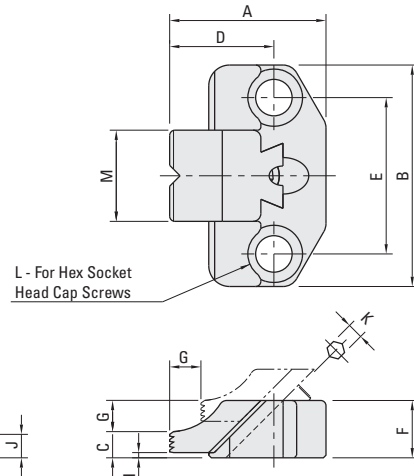

These adjustable side clamps have a low profile to keep clamp out of the way from machining operation. The serrated clamp jaws move downward and forward as it is engaged, forcing the work piece against the supports and stops. Allows for quick removal and insertion of parts. The body and jaw are made from SAE-4140 alloy steel, heat treated with black oxide finish.

Part #	A mm	B mm	C mm	D mm	E mm	F mm	G mm	H mm	J mm	K mm	L mm	M mm	Clamping Force lbs.	Screw Torque Ft. lbs.
CP104-08016	39.5	65	7.5	25	45	16	7	1.5	7	4	M8	25	890	5.9
CP104-12022	60.0	85	10.0	40	60	22	12	2.0	9	6	M12	35	2020	19.0
CP104-16030	77.0	100	14.0	50	70	30	14	2.0	13	8	M16	40	3800	44.0

SERRATED ADAPTORS

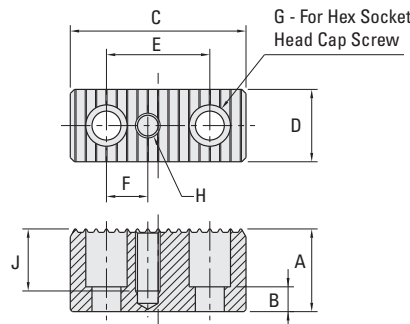
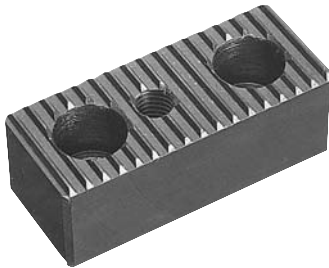

How To Use

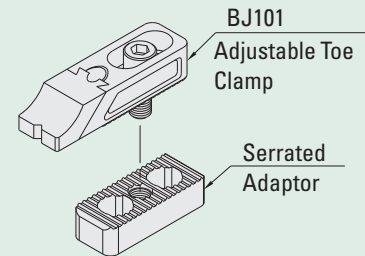

These serrated adaptors are used with the adjustable toe clamps (Series BJ101) and adjustable side clamps. (Series BJ102) They are serrated on the top to match the serrations on the bottom of the clamps. These serrated adaptors are ideal for raising the height and firmly positioning these clamps. They have a tapped hole to mount the clamps. The adaptors mount with socket head caps screws. Made from SAE-1045 alloy steel with black oxide finish.

Part #	A mm	B mm	C mm	D mm	E mm	F mm	G mm	H mm	J mm
BJ500-08516	16	7	50	25	25	12.5	M8	M8X1.25	Through
BJ500-08520	20	9	50	25	25	12.5	M8	M8X1.25	Through
BJ500-08525	25	13	50	25	25	12.5	M8	M8X1.25	20
BJ500-08532	32	20	50	25	25	12.5	M8	M8X1.25	20
BJ500-08540	40	28	50	25	25	12.5	M8	M8X1.25	20
BJ500-08550	50	38	50	25	25	12.5	M8	M8X1.25	20
BJ500-12020	20	5	85	35	50	20	M12	M12X1.75	Through
BJ500-12025	25	10	85	35	50	20	M12	M12X1.75	Through
BJ500-12032	32	12	85	35	50	20	M12	M12X1.75	Through
BJ500-12040	40	12	85	35	50	20	M12	M12X1.75	30
BJ500-12050	50	12	85	35	50	20	M12	M12X1.75	35
BJ500-16025	25	6	90	40	50	25	M16	M16X2	Through
BJ500-16032	32	13	90	40	50	25	M16	M16X2	Through
BJ500-16040	40	15	90	40	50	25	M16	M16X2	30
BJ500-16050	50	15	90	40	50	25	M16	M16X2	35
BJ500-16063	63	15	90	40	50	25	M16	M16X2	35