

## SPIRAL CAM EDGE CLAMPS

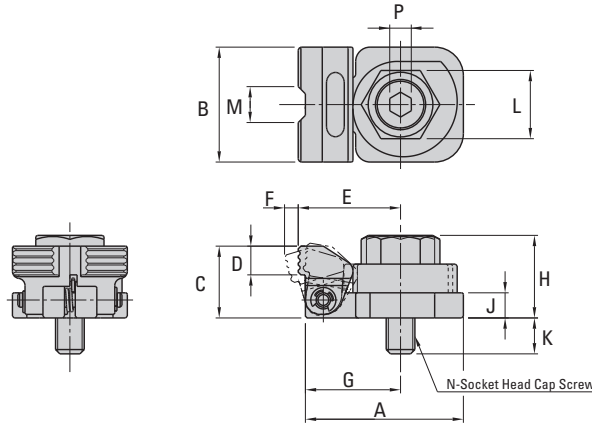

### How To Use

Fasten the body and the flanged collar with a socket head cap screw, then turn the cam with a wrench to clamp a workpiece.

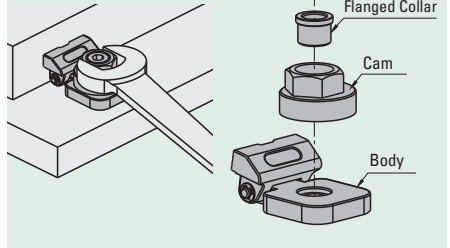

These cam edge clamps offer a low profile design, high holding forces and easy to use operations. The low profile and small size allow for faster set up and more parts per load. Turning the cam nut on the top of the clamp forces the serrated jaw forward and downward against the work piece. Easily installs with a socket head cap screw. The body and jaw are made from SAE-4140 alloy steel, heat treated with black oxide finish. The cam is made from SAE-4135 alloy steel with black oxide finish.

Part #	Clamping Force lbs.	Max Torque Ft./lbs.
BJ162-08001	788	33
BJ162-10001	1,238	41
BJ162-12001	1,575	52

Part #	A mm	B mm	C mm	D mm	E mm	F mm	G mm	H mm	J mm	K mm	L mm	M mm	N mm	P mm
BJ162-08001	44	32	20	8	28.5	4	26.5	23	7	15	19	10	M8x1.25 - 30L	6
BJ162-10001	54	40	25	10	35	5	33	29	9	16	24	12	M10x1.5 - 35L	8
BJ162-12001	62	46	30	12	39.5	5.5	37.5	35	11	17	27	14	M12x1.75 - 40L	10

## SPIRAL CAM CLAMPS

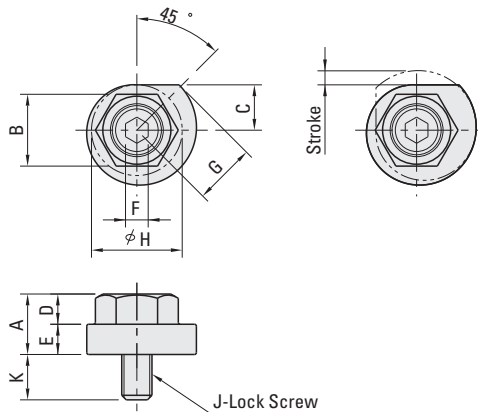

### How To Use

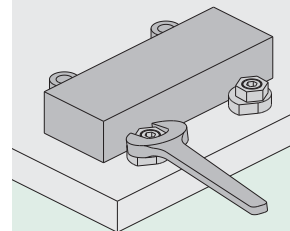

Provides Positive Clamping

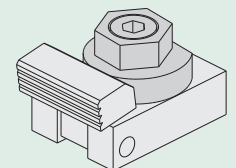

Can also be used as clamping mechanism for custom clamps.

Compact design for low profile positive clamping. These clamps permit faster loading and unloading of work piece. To install, lock the flange collar into the cam using the locking screw and then tighten up the cam with a wrench. The cam and locking screw are made from SAE-4135 alloy steel. The flanged collar is made from SAE-1095 alloy steel. Parts are heat treated with black oxide finish.

Part #	A mm	B mm	C mm	D mm	E mm	F mm	G mm	H mm	J mm	K mm	Stroke mm	Clamping Force lbs.	Screw Torque Ft. lbs.
BJ161-08001	16	19	12	8	8	6	16.38	24	M8X1.25	12	4	1168	36
BJ161-10001	20	24	15	10	10	8	20.47	30	M10X1.50	15	5	1798	55
BJ161-12001	24	27	17	12	12	10	23.20	34	M12X1.75	18	6	2090	66